

# LOCOMOTIVE BOILERS AND ENGINES

A PRACTICAL TREATISE ON LOCOMOTIVE BOILER AND ENGINE  
DESIGN, CONSTRUCTION, AND OPERATION

BY

LLEWELLYN V. LUDY, M.E.

PROFESSOR OF EXPERIMENTAL ENGINEERING, PURDUE  
UNIVERSITY

AMERICAN SOCIETY OF MECHANICAL ENGINEERS

ILLUSTRATED

AMERICAN TECHNICAL SOCIETY

CHICAGO

1920

Copyright 1909, 1913, 1914, 1917, 1920, by

AMERICAN TECHNICAL SOCIETY

-----

COPYRIGHTED IN GREAT BRITAIN

ALL RIGHTS RESERVED

# INTRODUCTION

OF ALL heat engines, the locomotive is probably the least efficient, principally due, no doubt, to the fact that it is subject to enormous radiation losses and to the fact that it must carry its own steam plant. However, even with these serious handicaps, the utility and flexibility of this self-contained power unit are so great that only in a comparatively few instances have the railroads been able to see their way clear to adopt electric locomotives and, even in these cases, only for relatively small distances.

Stephenson's "Rocket" was in its day considered a wonder and when pulling one car was capable of a speed of probably 25 miles per hour. The fact that our present-day "moguls" can draw a heavy limited train at 80 miles per hour gives some indication of the theoretical and mechanical developments which have made this marvelous advance possible.

In the development of any important device, what seem to us now as little things often have contributed largely to its success-- nay more, have even made that success possible. No locomotive had been at all successful until Stephenson hit upon the idea of "forced draft" by sending the exhaust steam out of the smokestack. This arrangement made possible the excessive heat of the furnace necessary to form steam rapidly enough to satisfy the demand of the locomotive. From that time on the progress made was merely a question of taking advantage of improvements in workmanship and design and later of such valuable principles as compound expansion, valve gearing, etc.

The historical development of the locomotive and the discussion of the theoretical and mechanical improvements, which have made it what it is today, are exceedingly important to the engineer and of great interest to the layman. The practical side of the subject has been exceptionally well handled in this book and will be found profitable to all readers.

# CONTENTS

	page
<b><u>Introduction</u></b>	<b>3</b>
<b><u>Contents</u></b>	<b>4</b>
<b><u>Historical development of locomotive</u></b>	<b>10</b>
Trevithick's locomotive	10
The Rocket	11
Best Friend of Charleston	12
Camel-Back	12
Hayes 10-Wheeler	13
The Daniel Nason	13
The Reuben Wells	14
American type locomotive	15
Compound locomotives	16
<b><u>Classification of locomotives</u></b>	<b>18</b>
Whyte system	18
Mogul type	19
Consolidation type	21
Atlantic type	22
Pacific type	22
Cole four-cylinder balanced compound locomotive	25
Mallet articulated compound locomotive	26
Cross-compound locomotive	37
<b><u>Action of steam in operating locomotive</u></b>	<b>40</b>
General course of steam	40
Steam enters steam chest	40
Steam enters cylinder	40
Steam in cylinder	41
Steam after leaving cylinder	41
<b><u>Locomotive boilers</u></b>	<b>42</b>
Classification of boilers as to form	42
Classification of boilers as to fire-box used	42
Flues	47
Stay-bolts	48
Grates	53
Ash pans	54
Brick arches	55



	<b>page</b>
Smoke-box and front end arrangement	<b>57</b>
Steam or branch pipes	<b>57</b>
Exhaust nozzle	<b>57</b>
Netting	<b>57</b>
Diaphragm	<b>57</b>
Draft pipes	<b>57</b>
Draft	<b>57</b>
Exhaust nozzles	<b>58</b>
Stack	<b>60</b>
Rate of combustion	<b>61</b>
Spark losses	<b>63</b>
High steam pressures	<b>63</b>
Effect of different pressures upon boiler performance	<b>63</b>
Effect of different pressures upon smoke-box temperatures	<b>64</b>
Heating surface	<b>65</b>
Superheaters	<b>66</b>
Locomotive boiler design	<b>76</b>
Boiler capacity	<b>79</b>
Locomotive engine	<b>82</b>
Lead	<b>82</b>
Outside lap	<b>82</b>
Inside clearance	<b>82</b>
<b>Valve motion</b>	<b>83</b>
Requirements	<b>83</b>
Stephenson valve gear	<b>83</b>
Walschaert valve gear	<b>87</b>
Comparison between Stephenson and Walschaert gears	<b>89</b>
Valves	<b>92</b>
Valve friction	<b>94</b>
<b>Running gear</b>	<b>96</b>
Wheels	<b>96</b>
Axles	<b>101</b>
Crank pins	<b>102</b>
Locomotive frames	<b>103</b>
Cylinder and saddle	<b>105</b>
Piston and rods	<b>105</b>
Crossheads and guides	<b>107</b>

	page
Connecting or main rods	108
Parallel or side rods	109
Locomotive trucks	110
Tender	114
Locomotive stokers	115
<b><u>Design of parts of engine</u></b>	<b>118</b>
Axles	118
Crank pins	122
Piston rods	124
Frames	125
Cylinders	126
Locomotive rating	130
<b><u>Locomotive appliances</u></b>	<b>133</b>
Safety valves	133
Injector	135
Whistle	137
Steam gauges	139
Water gauges	139
Blower	139
Throttle valve	140
Dry pipe	140
Lubricator	140
Air brake and signal equipment	141
<b><u>Railway signaling</u></b>	<b>143</b>
Whistle signals	143
Bell cord signals	144
Movable signals	144
Train signals	145
Fixed signals	149
Block system	151
<b><u>Locomotive operation</u></b>	<b>154</b>
Running	154
Inspection	157
Cleaning	157
Repairs	157
Emergencies	157
<b><u>Train rules</u></b>	<b>159</b>

	page
<b>Time tables</b>	<b>162</b>
<b>Locomotive troubles and remedies</b>	<b>163</b>
Distinctive features of locomotive	163
Pounds	163
Steam waste	164
Care of boiler	165
Drifting	166
Fuel waste	167
<b>Locomotive breakdowns</b>	<b>168</b>
Possible Causes	168
Derailments	168
Explosion of boiler	169
Collapse of flue	169
Disconnecting after breakdown	169
<b>Duties of locomotive engineer</b>	<b>171</b>
Watching his road	171
Care of locomotive	175

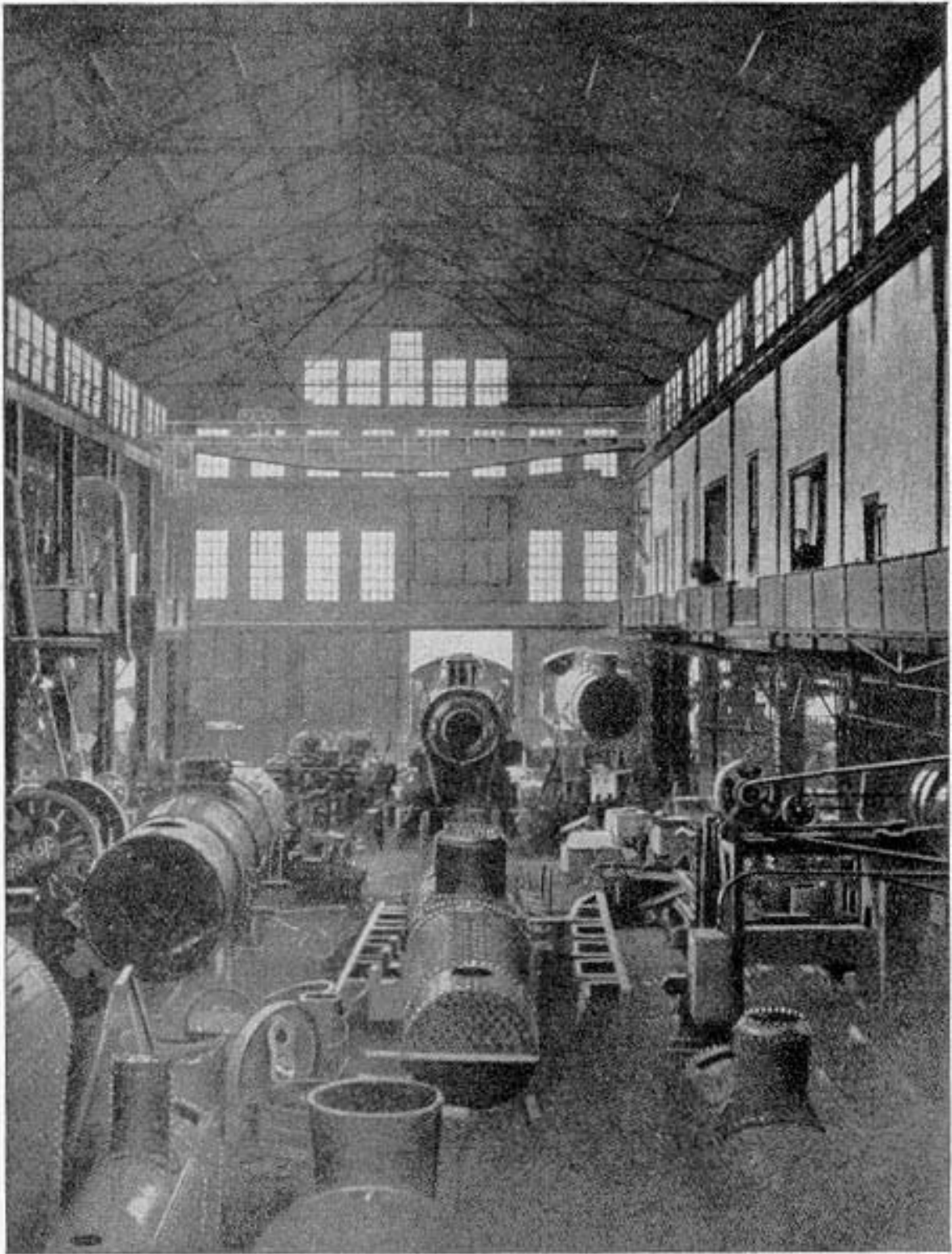

**ROD LOCOMOTIVE ERECTING ROOM**  
*Courtesy of Lima Locomotive Corporation, Lima, Ohio*

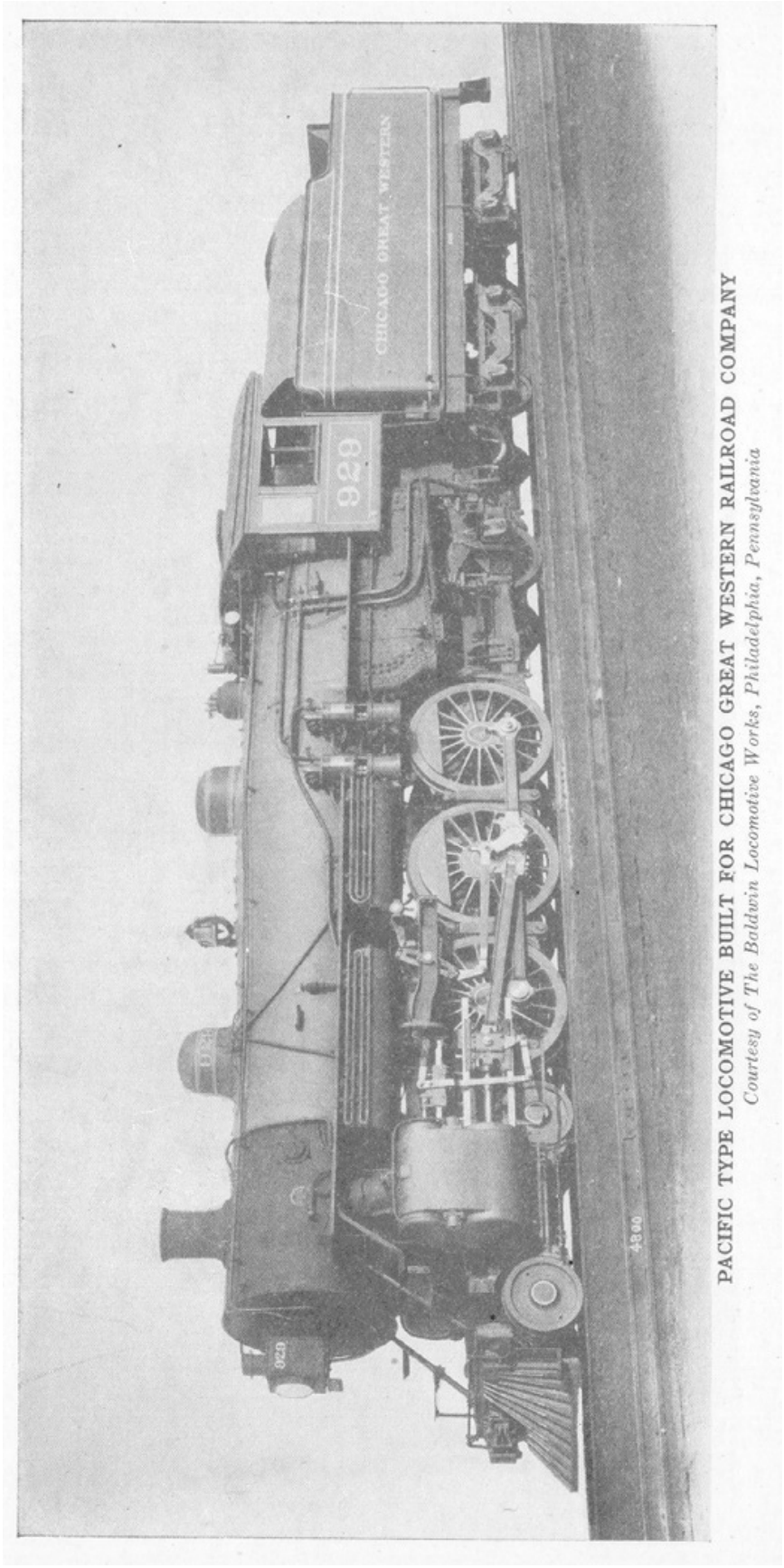

PACIFIC TYPE LOCOMOTIVE BUILT FOR CHICAGO GREAT WESTERN RAILROAD COMPANY  
*Courtesy of The Baldwin Locomotive Works, Philadelphia, Pennsylvania*

# LOCOMOTIVE BOILERS AND ENGINES

## PART I

### HISTORICAL DEVELOPMENT OF THE LOCOMOTIVE

The first locomotive engine designed to run upon rails was constructed in 1803, under the direction of Richard Trevithick, a Cornish mine captain in South Wales. Though crudely and peculiarly made, it possessed all of the characteristics of the modern locomotive with the exception of the multi-tubular boiler. The locomotive had a return-flue boiler 60 inches long, and two pairs of driving wheels - each 52 inches in diameter. The power was furnished by one cylinder, 54 inches long and 8 inches in diameter.

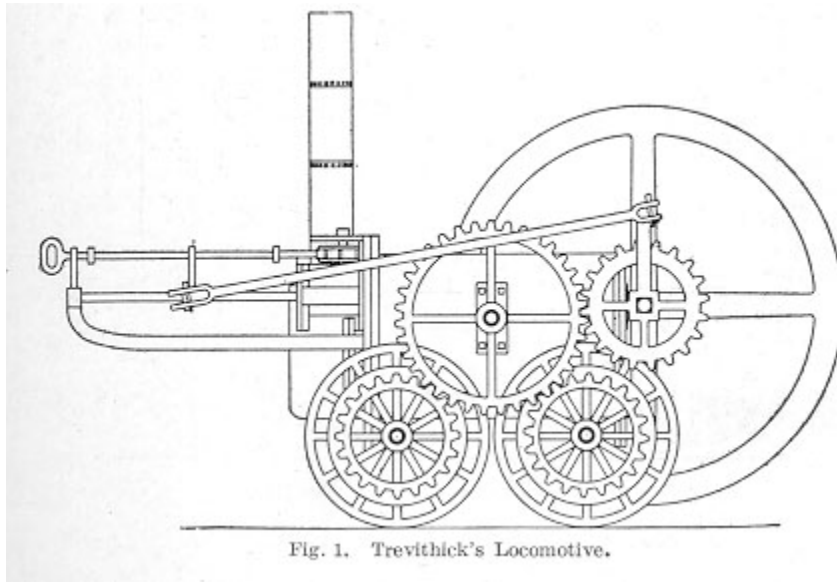

The exhaust steam from the cylinder was conducted to the smoke-stack where it aided in creating a draft on the fire. This engine, shown in [Fig. 1](#), made several trips of nine miles each, running about five miles per hour and carrying about two tons. Although the machine was a commercial failure, yet from a mechanical standpoint, it was a great success.

After the development of the Trevithick locomotive, numerous experiments were tried out and many engineers were working on a new design. As a consequence, many very crude but interesting locomotives were developed. The principal objection raised against the most of them was in reference to the complicated parts of the mechanism. Having had no previous experience to direct them, they failed to see that the fewer and simpler the parts of the machine, the better. It was not until about 1828, when the *Rocket*, as shown in [Fig. 2](#), was built under the supervision of Robert Stephenson, that anything of note was accomplished. The *Rocket*, in a competition speed test, without carrying any load, ran at the rate of 29½ miles per hour. With a car carrying thirty passengers, it attained a speed of 28 miles per hour. The construction of the *Rocket* was a step in the right direction, since it contained fewer and simpler parts. It had an appearance similar to the modern locomotive, having a multitubular boiler, induced draft by means of the exhaust steam, and a direct connection between the piston rod and crank pin secured to the driving

wheel. The cylinder was inclined and proportions were very peculiar as compared with the modern locomotive, yet much had been gained by this advancement.

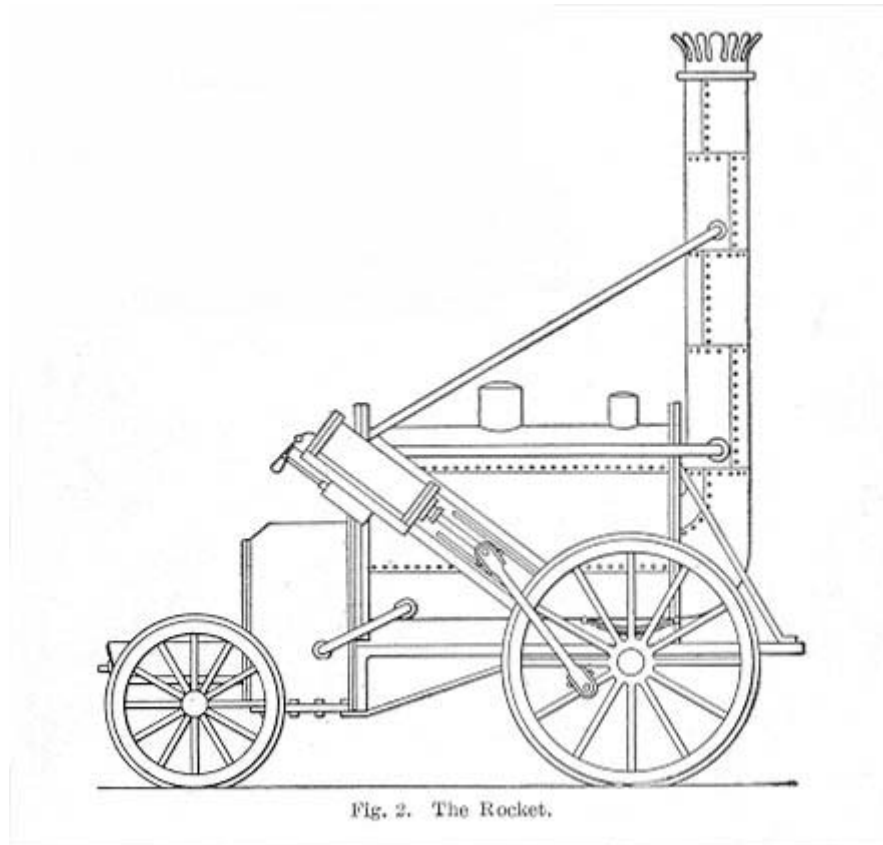

While these things were being accomplished in England, the fact must be noted that agitation in favor of railroad building in America was being carried on with zeal and success. Much of the machinery for operating the American railroads was being designed and built by American engineers, so it is quite generally believed that railroad and locomotive building in America would not have been very much delayed had there never been a Watt or a Stephenson.

The first railroad opened to general traffic was the Baltimore & Ohio, which was chartered in 1827, a portion being opened for business in 1830. About the same time, the South Carolina Road was built. The board of directors of this road were concerned with what kind of power to use, namely, horse-power or steam engines. After much deliberation, it was finally decided to use a steam-propelled locomotive.

The history of this period is interesting. The first steam locomotive built in America was the *Best Friend of Charleston*, illustrated in [Fig. 3](#). One year previous to the building of this locomotive, an English locomotive called *Stourbridge Lion* was imported by the Delaware-Hudson Canal Co. It was tried near Homesdale. A celebrated American engineer by the name of Horatio Allen, made a number of trial trips on this locomotive and pronounced it too heavy for the American roadbeds and bridges; so it was that the *Best Friend of Charleston*, an American locomotive constructed in 1830, gave the first successful service in America. The *Best Friend of Charleston* was a four-wheeled engine having two inclined cylinders. The wheels were constructed of iron hubs with wooden spokes and wooden fellows, having iron tires shrunk on in the usual way. A vertical



boiler was employed and rested upon an extension of the frame which was placed between the four wheels. The cylinders, two in number, were each 6 inches in diameter and had a common stroke of 16 inches. The wheels were 4½ feet in diameter. The total weight of the locomotive was about 10,000 pounds. Assuming power by present methods, it would develop about 12 horse-power while running at a speed of 20 miles per hour and using a steam pressure of 50 pounds.

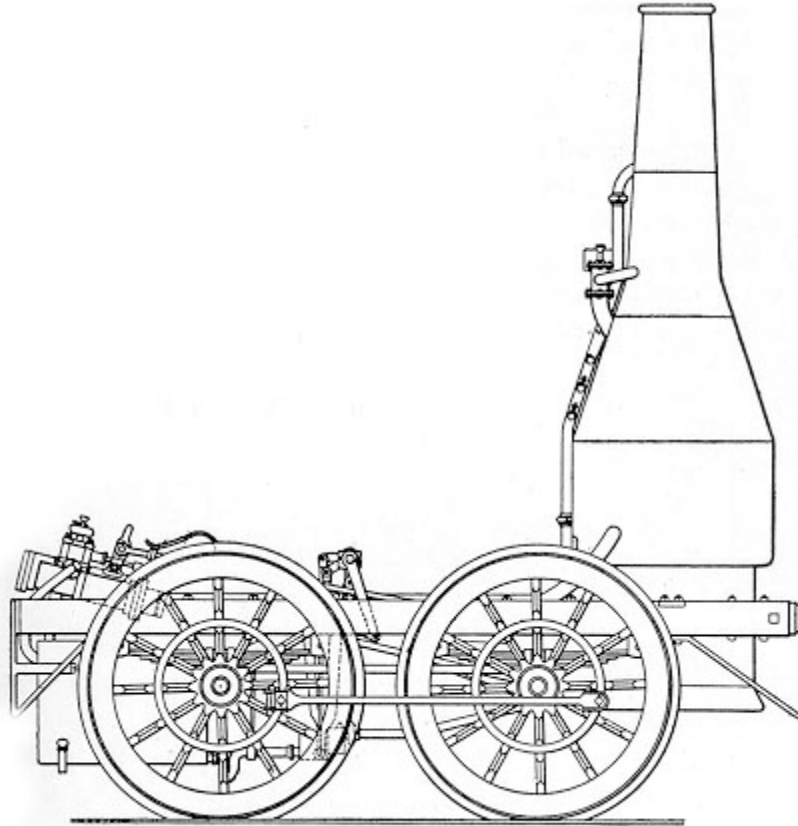

Fig. 3. The Best Friend of Charleston.

The Baltimore & Ohio Railroad was the leader for a number of years in the development of the locomotive. Among the earlier designs brought out by this road was an 8-wheeled engine known as the *Camel-Back*, so-called from its appearance, and frequently spoken of as the *Winans*, as its design was developed in 1844 by Ross Winans, a prominent locomotive builder of a half century ago.

The illustration shown in [Fig.4a](#) represents the *Hayes 10-Wheeler* with side rods removed, which was built after designs prepared in 1853 by Samuel J. Hayes of the B. & O. [Fig. 4b](#) is from an original drawing of one of the earlier types of the same engine and shows more of the details of construction. This locomotive is oftentimes improperly called the *Camel-Back* or *Winans* engine because of its close resemblance to the *Winans*. The name *Camel-Back*, as given to the *Winans* engine and also to the *Hayes 10-Wheeler*, was given on account of the peculiar appearance of the locomotive, which, in fact, did resemble a camel's humped back. This appearance was due to the fact that a large cab was placed on the central portion of the boiler, and also to the rapidly receding back end of the boiler. The weight of the *Hayes 10-Wheeler* is 77,100 pounds, of which 56,500 pounds are on the drivers and 20,060 pounds are on the front truck. The diameter of the



front truck wheels is 28 inches and that of the drivers, 50 inches. The fire-box is  $42\frac{1}{4}$  inches long and  $59\frac{1}{4}$  inches wide. The boiler has a total heating surface of 1,176.91 square feet, 1,098 square feet of this amount being in the flues. There are 134 tubes  $2\frac{1}{4}$  inches in diameter and 13 feet 11 inches long.

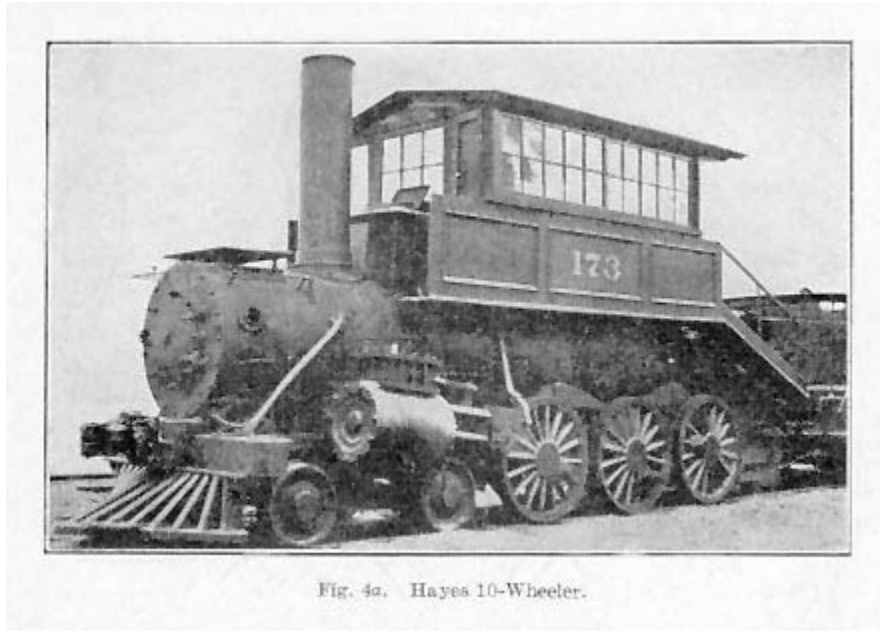

Fig. 4a. Hayes 10-Wheeler.

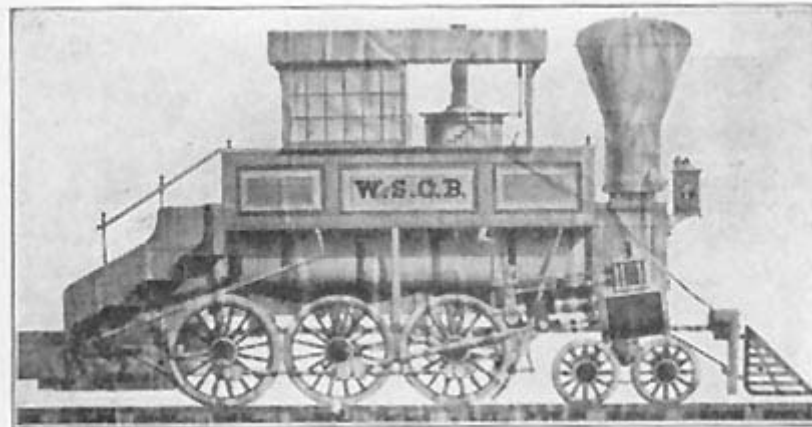

Fig. 4b. Hayes 10-Wheeler.

The Boston & Providence Railroad built several locomotives during the time the Winans locomotive was being developed. One of these, the *Daniel Nason*, illustrated in [Fig. 5](#), was built in 1858. The *Daniel Nason* weighs 52,650 pounds, has 16 by 20 inch cylinders, 54-inch driving wheels, and 30-inch truck wheels. Steam pumps were used in feeding the boiler instead of the injectors. The top members of the frame are built up of rectangular sections, while for the bottom members, 4-inch tubes are used.

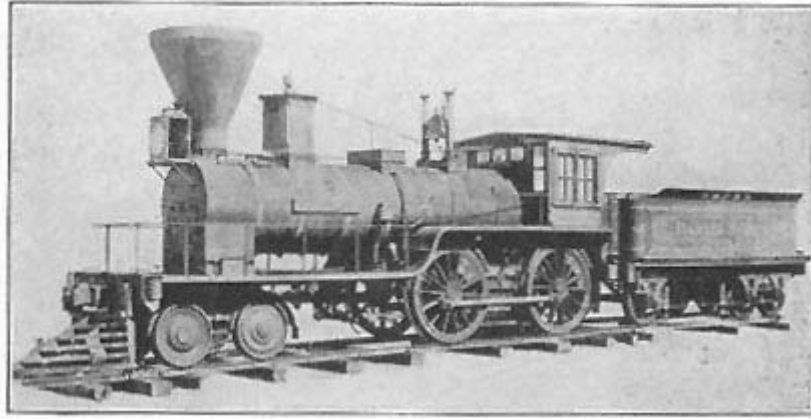

Fig. 5. The Daniel Nason.

The prevailing thought in the early development of the locomotive was, that sufficient power could not be secured by depending upon the adhesion of the drivers to the rail; as a consequence many cog locomotives were developed and used. This was true on the old Jeffersonville, Madison & Indianapolis Railroad at Madison, Indiana. A portion of the road at that point included a six per cent grade three miles long. From the opening of the road in 1848 until 1858, the grade was operated by cog locomotives. On the last-named date, there appeared a locomotive named the *Reuben Wells* which was destined to have both a very interesting and successful career.

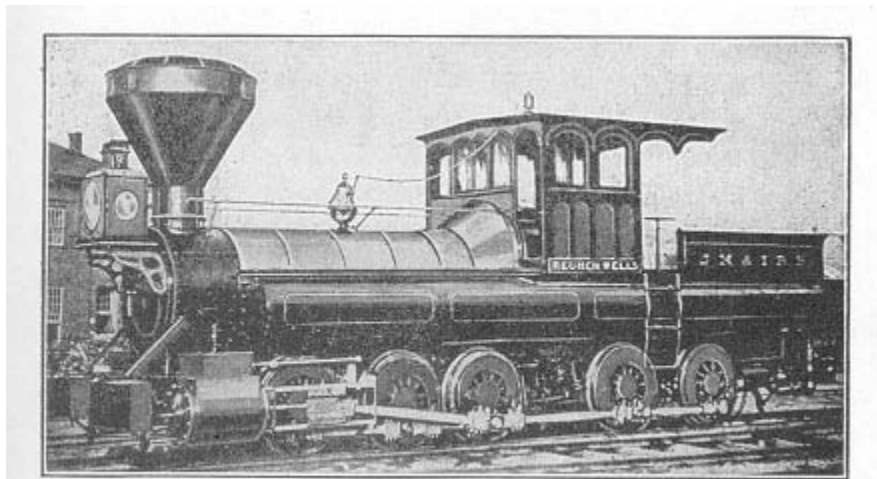
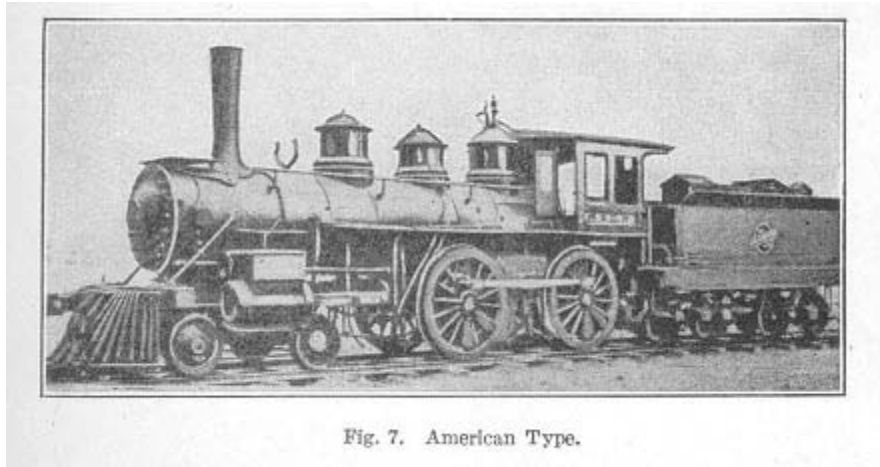

Fig. 6. The Reuben Wells.

The Reuben Wells, illustrated in [Fig. 6](#), was designed by Mr. Reuben Wells, then a master mechanic of the road. It was built in the company's shops at Jeffersonville, Indiana, in July, 1858. The Reuben Wells has cylinders 20 X 24 inches, and five pairs of drivers each 49 inches in diameter, all being coupled. No front truck is used. The boiler is 56 inches in diameter and contains 201 two-inch flues 12 feet 2 inches in length. It has a heating surface in the fire-box of 116 square feet while that in the tubes is 1,262 square feet. It is what is commonly known as a *tank locomotive* since it carries the water and fuel upon the frame and wheels of the engine proper instead of upon a separate part, the tender. The total weight with fuel and water is 112,000 pounds. The tractive effort under a steam pressure of 100 pounds per square inch is about 21,818 pounds on a level road. After having been in service for a number of years, it was rebuilt with four instead of five pair of drivers and was shortened by the cutting off of a section at the rear which had

been used for coal and water. Sufficient water capacity was provided by placing a tank over the boiler.



The American type locomotive, illustrated in [Fig. 7](#), is typical of the small sized engines of this construction which are now being rapidly replaced by other types. For a period of nearly fifty years ending about 1895, the American type locomotive was more commonly used for passenger service than any other type.

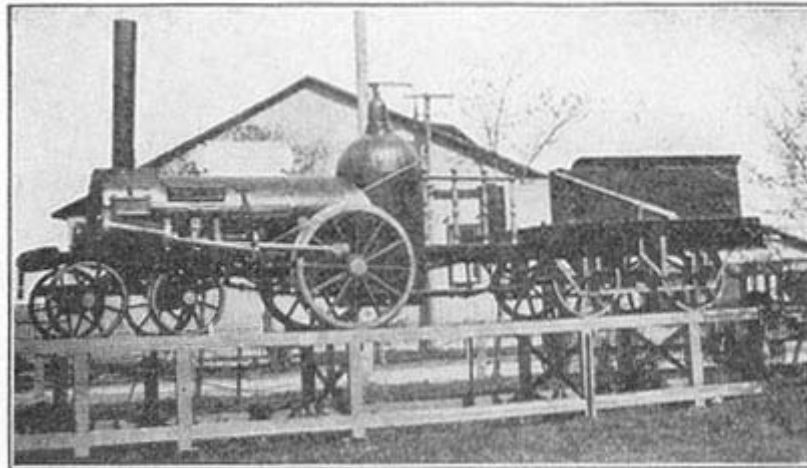

A comparison of things with reference to size, weight, and color impresses their relative characteristics upon the mind. For this reason, the illustrations of the *Tornado* and the *Mallet* compound locomotives are given in [Fig. 8](#) and [Fig. 9](#), respectively, the former being an early development, and the latter the most recent heavy freight locomotive.

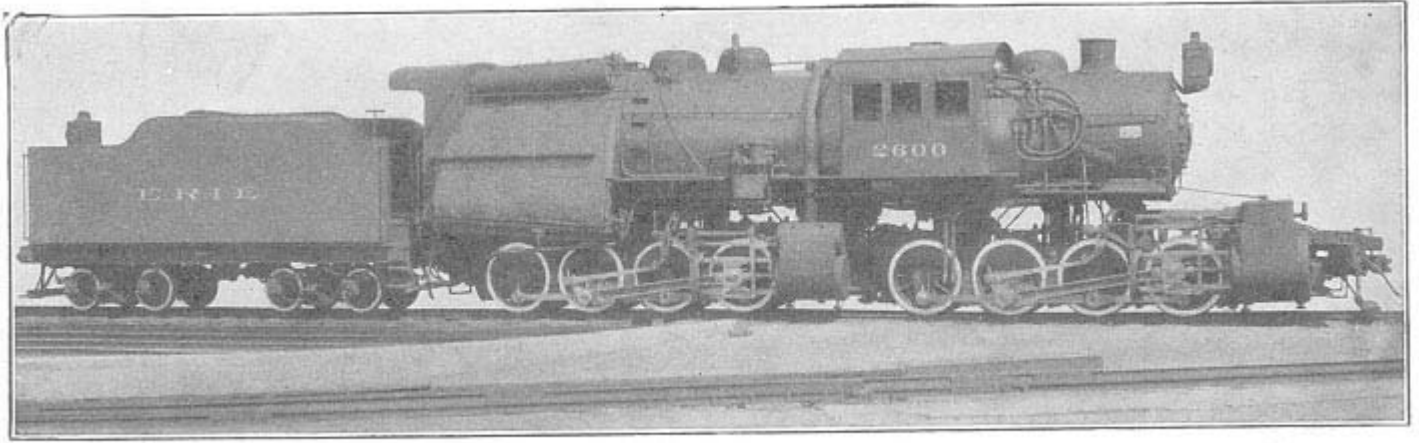

Fig. 9. Mallet Compound Locomotive.

The Tornado was the second locomotive owned by one of the parent lines forming a part of the Seaboard Air Line Railroad. This locomotive was imported from England and put into service in March, 1840. It has two inclined cylinders 9 inches in diameter with a common stroke of 20 inches and a single pair of drivers 54 inches in diameter. The fire-box stands upright and is cylindrical in form, while the boiler proper is horizontal and but 34 inches in diameter. The steam is admitted to an exhaust from the cylinders by plain slide valves controlled by the *Hook* motion.

The Mallet compound locomotive marks one of the most successful attempts of the locomotive designer and builder. It surpasses anything thus far built in size and combination of new ideas in design. The one shown in the illustration was built for the Erie Railroad for heavy pushing service. It has a boiler diameter of 84 inches and carries a steam pressure of 215 pounds per square inch. The boiler contains 404 two and one-fourth inch flues 21 feet long. Its high-pressure and low-pressure cylinders are 25 and 39 inches in diameter, respectively, having a common stroke of 28 inches. The drivers, sixteen in number, are each 64 inches in diameter. The total weight on the drivers is 410,000 pounds. The boiler has a total heating surface of 5313.7 square feet, 4971.5 of this number being in the tubes and 342.2 in the fire-box. The firebox is 126 inches long and 114 inches wide, giving 100 square feet of grate area. Its maximum tractive effort is 94,800 pounds.

It is of much interest to compare in a general way the developments of the locomotive in England and in America. The types differ in many respects, as shown in Table 1.

**TABLE I**

**\*Comparison of English and American Locomotives**

<b>Parts</b>	<b>English</b>	<b>American</b>
Frames	Plate	Bar
Cylinders	Inside	Outside
Drivers	Not equalized	Equalized
Driver Centers	Wrought iron	Cast iron or steel
Fire-box	Copper	Steel
Tubes	Brass	Iron
Cab	Small	Large
Pilot	No	Yes
Reverse gear	Screw	Lever
Boiler	Small and Low	Large and high

\* The comparisons are not strictly true for every case but represent the conditions usually found.

In order that a clear understanding may be had of the various types of locomotives, a classification is given according to wheel arrangement. In the Whyte system of classification, which is quite largely used, each set of trucks and driving wheels is grouped by number beginning at the pilot or front end of the engine. Thus, 260 means a Mogul, and 460, a 10-wheel engine. The first figure, 2, in 260 denotes that a 2-wheeled truck is used in front; the figure 6, that there are six coupled drivers, three on each side; and the 0, that no trailing truck is used. This scheme gives both a convenient and easy method of classifying locomotives.

In Table II is given the classification of the locomotives used on American railroads.

The method may be further extended to include the weights of locomotives. The total weight is expressed in units of 1,000 pounds. Thus: A Pacific locomotive weighing 189,000 pounds would be classified as Type 462-189. If the locomotive is a compound, a letter C would be used instead of the dash. Thus: Type 462-C-189. If tanks are used instead of a separate tender, the letter T would be substituted for the dash. Thus: A tank locomotive having four driving wheels, a 4-wheel leading truck, and a 4-wheel rear truck, weighing 114,000 pounds would be classified as Type 444-T-114.



**TABLE II**  
**Classification of Locomotives**  
**[WHYTE'S SYSTEM]**

040		4 Wheel
060		6 Wheel
080		8 Wheel
0440		Articulated
0660		Articulated
240		4 Coupled
260		Mogul
280		Consolidation
2440		Articulated
2100		Decapod
440		8 Wheel
460		10 "
480		12 "
042		4 Coupled and Trailing
062		6 " " "
082		8 " " "
044		Forney 4 Coupled
064		" 6 "
046		" 4 "
066		" 6 "
242		Columbia
262		Prairie
282		8 Coupled
2102		10 "
244		4 "
264		6 "
284		8 "
246		4 "
266		6 "
442		Atlantic
462		Pacific
444		4 Coupled Double Ender
464		6 " " "
446		4 " " "

From the classification table given, it is apparent that there are a great many different types of locomotives in service. Only the more commonly used types will be discussed, which are as follows: 040, 060, 080, 260, 280, 440, 442, 460, and 462. The types 040, 060, and 080 are largely used for switching service. The 040 type is of the smallest proportions and weights, being found in small yards where only light work is required. The call for heavy duty was met by the 060 type. The fact that the 060 type, being much heavier, has a greater tractive effort and a correspondingly larger steaming capacity, has caused them to be used very extensively. The following figures will aid in giving an idea of their size and capacity:

Weight on drivers (pounds). ....	145,000 to 170,000
Diameter of cylinders (inches). ....	19 to 22
Stroke of piston (inches). ....	24 to 26
Diameter of driving wheels (inches). ....	50 to 56
Working steam pressure (pounds per square inch).....	180 to 200

The demand for power, steadily increasing beyond that which could be secured by locomotives of the 060 type, created a new design known as the 8-wheel, or 080 type. This type is used in switching and pushing service and has about 171,000 pounds weight on drivers, cylinders 21 inches in diameter, stroke 28 inches, drivers 51 inches in diameter, and carries 175 to 200 pounds steam pressure. The switching engines of the 060 and 080 type were converted into highclass freight engines by adding two wheel trucks to each, thus developing the 260, or Mogul, and the 280, or Consolidation types.

The Mogul was primarily intended for freight service only, but it is sometimes used in heavy passenger service. The object of the design was to obtain greater tractive force on driving wheels than is possible to obtain with four drivers, as in the 440 type. [Fig. 10](#) illustrates a modern 260, or Mogul type, giving its principal dimensions. This type was more generally used than any other before the increasing requirements of heavy freight service resulted in the development of the 280, or Consolidation type. It is profitable from the standpoint of economy in repairs in selecting the type of locomotive for any service, to use the minimum number of drive wheels possible within the limits of the necessary tractive power, although for freight service involving the handling of heavy trains on steep grades, the 280, or Consolidation type, is required. Where the requirements are not too severe, however, there is a large field for the Mogul type in freight service. Where a large axle load is permitted, the Mogul type may give sufficient hauling capacity to meet ordinary requirements in freight service on comparatively level roads. While not generally recommended for what may be called fast freight service, the 280, or Consolidation type, is sometimes used. Many Mogul locomotives are successfully handling such trains.

The 260 type provides a two-wheel leading truck with good guiding qualities and places a large percentage of the total weight on the driving wheels. A large number of locomotives of this type show an average of 87½ per cent of the total weight of the locomotive on the drivers. Boilers with sufficient capacity for moderate speed may be provided in this type; and with relatively small diameters of driving wheels, it will lend itself readily to wide variations in grates and fireboxes.

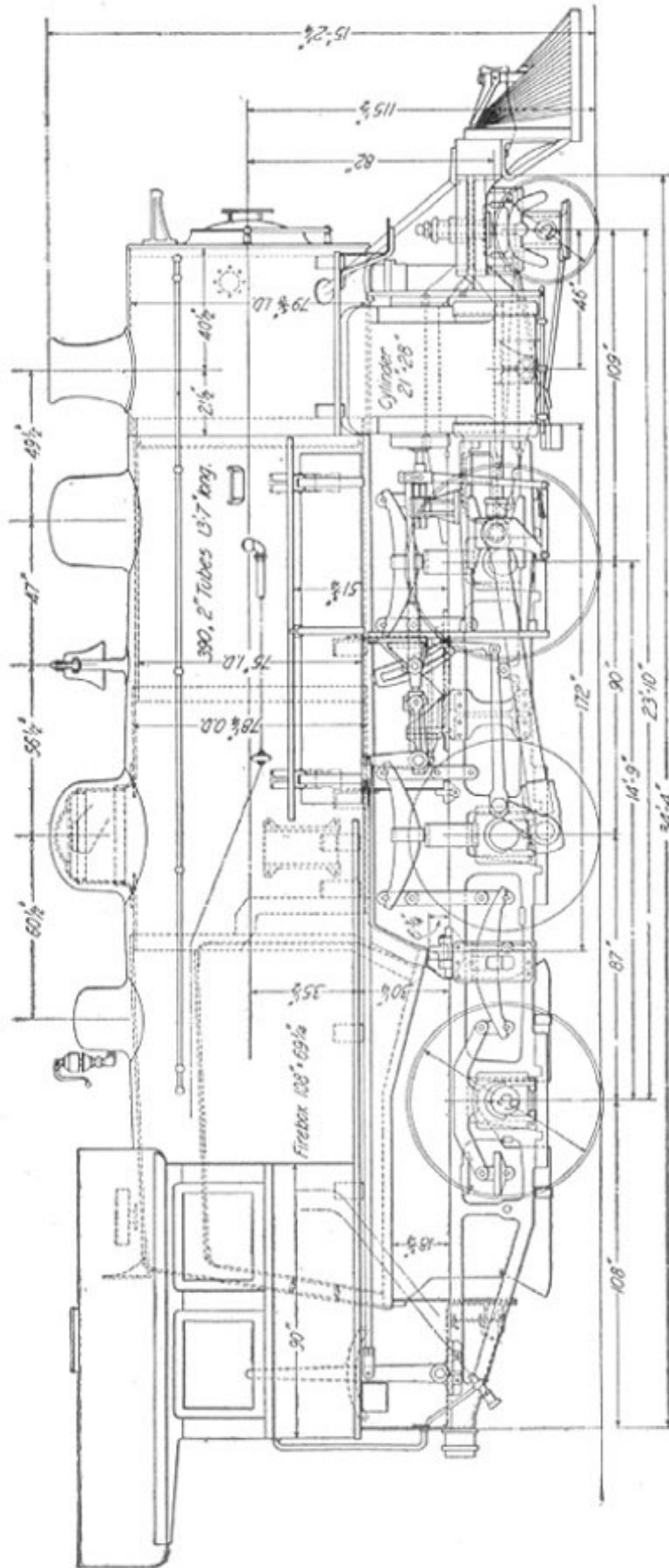

Fig 10. Modern 260, or Mogul Type of Locomotive.



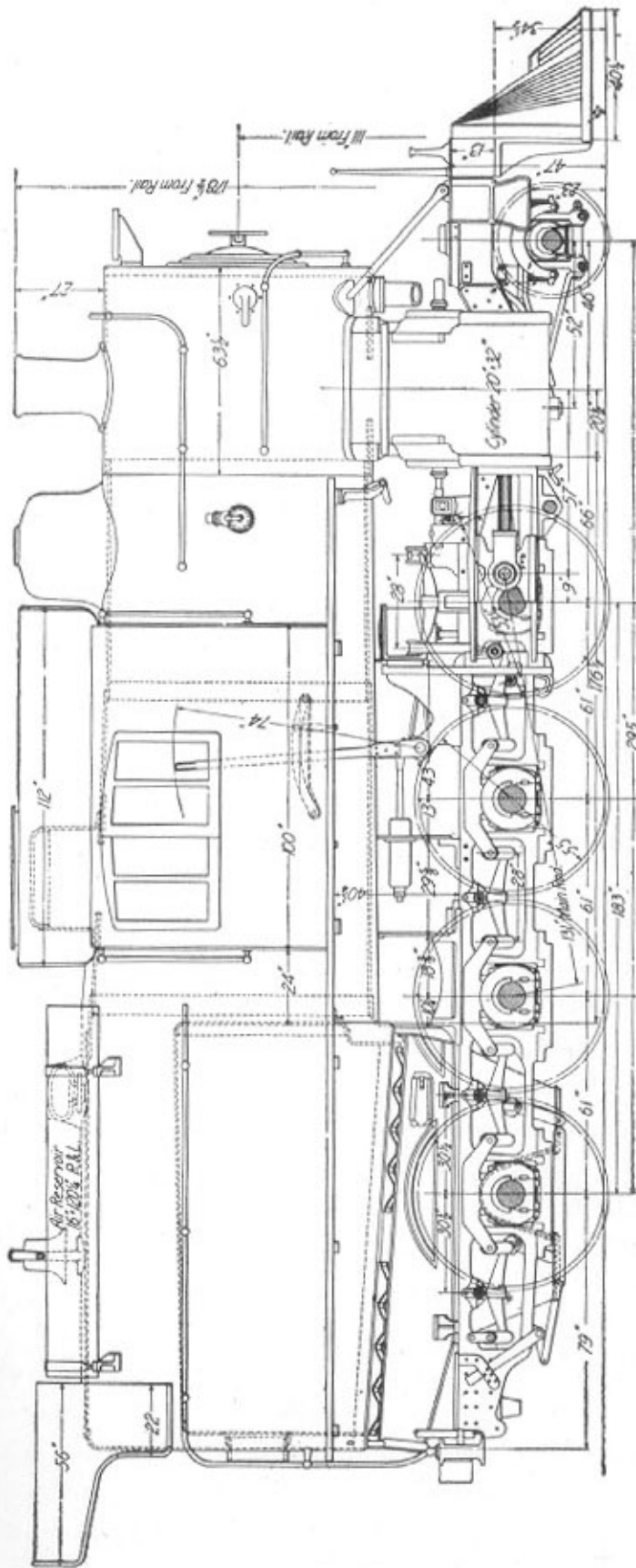

Fig. 11. A 280, or Consolidation Type of Locomotive.

The Consolidation locomotive, or 280 type, shown in [Fig. 11](#), was designed, as has been mentioned, for hauling heavy trains over steep grades. It is perhaps more generally used as a high class freight engine than any other type so far developed. Locomotives of this type have been designed and built with total weights varying between 150,000 to 300,000 pounds.

The four most prominent types of passenger locomotives, namely, 440, 442, 460, and 462, have each been developed at different times and in successive order to meet the ever-increasing and changing demands. The 8-wheel or 440 type, commonly known as the *American type*, was for some time the favorite passenger locomotive, but as the demands for meeting the conditions of modern fast passenger service increased, a locomotive of new design was required. The conditions which were to be met were *sustained high speed* and *regular service*. This did not mean bursts of high speed under favorable conditions with a light train running as an extra or special with clear orders, but it meant rather the more exacting requirements of regular service.

Where regular train service had to be sustained day after day at a schedule of 50 miles per hour, it required reserve power to meet the unfavorable conditions of the weather and for an occasional extra car in the train. For such exacting demands, much steam is required and ample heating and grate surface must be provided. In the 440 type with a 4-wheel leading truck and four driving wheels without a trailing truck, the boiler capacity is limited. Not only is the heating surface also limited but the grate area as well, because the grates must be placed between the driving wheels. The desirability of larger boilers and wider grates than the distance between the wheels in the 440 type will permit, led to a ready acceptance of the 442, or Atlantic type locomotive, as shown in [Fig. 12](#). The 442 type combines a 4-wheel leading truck, providing good guiding qualities, and four coupled driving wheels having a starting capacity sufficient for trains of moderate weight, and a trailing truck. The use of the trailing truck permits the extension of the grates beyond the driving wheels thus obtaining a much larger grate area. This wheel arrangement also permits the use of a deep as well as a wide fire-box which is especially advantageous in the burning of bituminous coal. It also gives a much greater depth at the front or throat of the fire-box, which is very important.

As modern passenger service increased and heavier trains had to be drawn, four driving wheels would not give sufficient starting power. Because of the heating surface and grate area being limited by the same factors as mentioned in the 440 type, another type, the 462, or Pacific type, came into favor. As this type was called upon to pull the heaviest passenger trains, much power was required even under very favorable conditions. For such trains, a locomotive having a combination of large cylinders, heavy tractive weight, and large boiler capacity is required. The Pacific type meets these requirements in a very successful way. From a study of [Fig. 13](#), which illustrates such a locomotive, it is obvious that the 462 type differs from the general design of the Atlantic type only in the addition of another pair of driving wheels. This, however, makes possible a much heavier boiler; therefore, more heating surface, more grate area, and greater tractive weight are obtained. Grate areas of from 40 to 50 square feet are possible in this type which provides for the large fuel consumption that is required for the rather severe service. The heating surface is of equal importance since large cylinders require large steaming capacity. The 462 type meets this need also. A comparison of passenger locomotives shows that the Pacific type has more heating surface for a given total weight than is found in any other type of passenger locomotive.

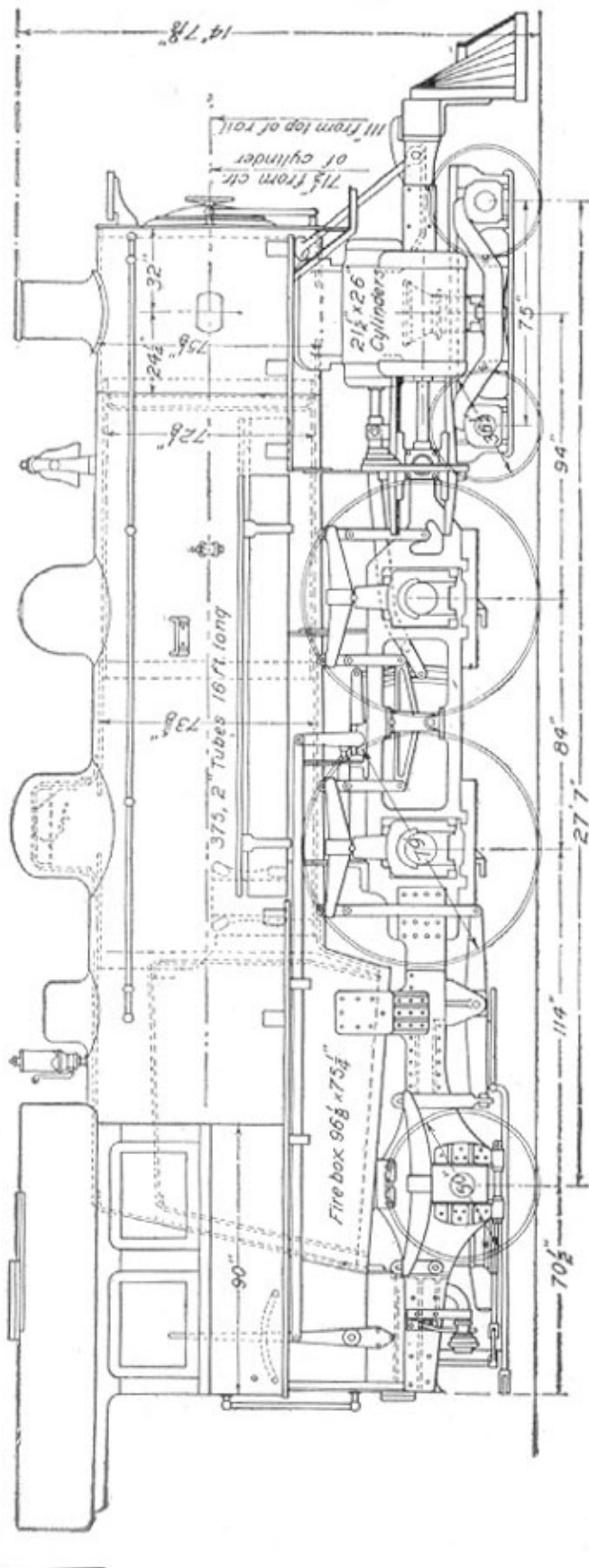

Fig. 12. A 442, or Atlantic Type of Locomotive.

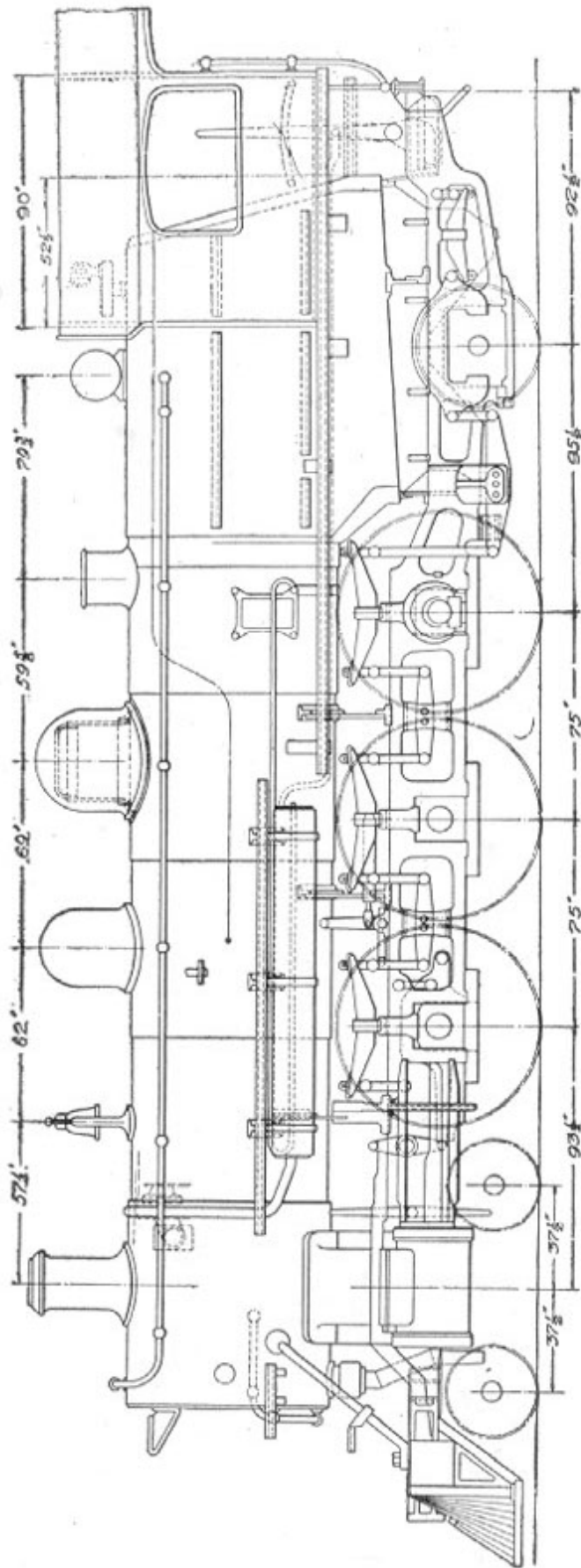

Fig. 13. A 462, or Pacific Type of Locomotive for Very Heavy Passenger Service.

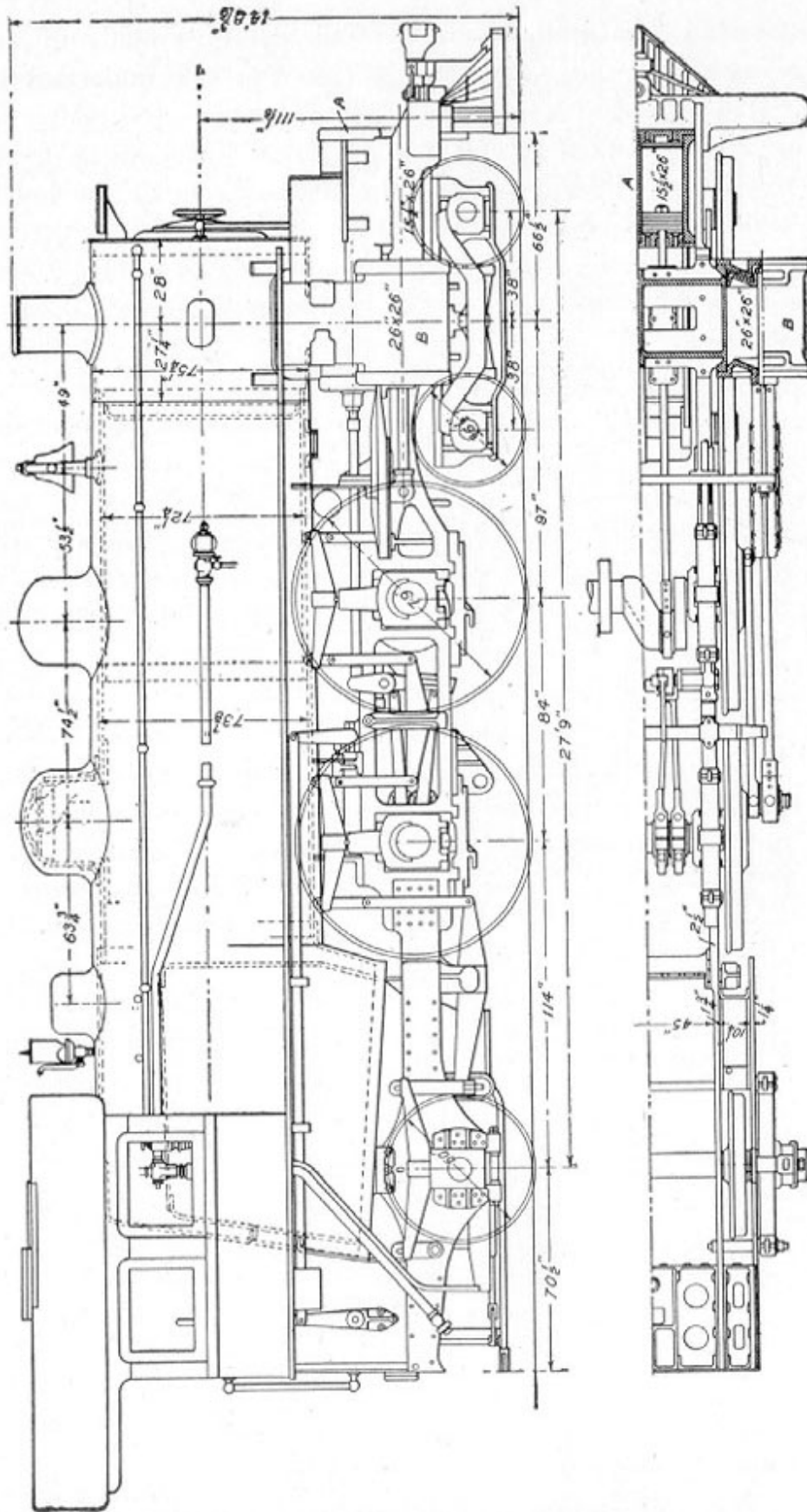

Fig. 14. Elevation of a Cote Four-Cylinder Balanced Compound Locomotive.  
 Fig. 15. Plan of the Same Locomotive.

**Compound Locomotive.** In continuation of a study of the development of the various types of locomotives, it is important to consider the compound locomotive. The compound locomotive is one in which the steam is admitted to one cylinder, called the *high-pressure cylinder*, where it partially expands. From this cylinder the steam is exhausted into the steam chest of another cylinder having larger dimensions, called the *low-pressure cylinder*. From this steam chest, the steam enters the low-pressure cylinder where it continues its work and is exhausted into the atmosphere. There have been a large number of different types of compound locomotives developed, all of which have had more or less merit. The following types have been used in America: the four-cylinder balance compound, the Mallet compound, and the tandem compound. The remarks and description which follow, of the *Cole four-cylinder compound*, are quoted from publications of the American Locomotive Company, builders of this locomotive:

The time has arrived when merely increasing weight and size of locomotives to meet increasing weights of trains and severity of service does not suffice. To increase capacity, improve economy, and at the same time reduce injury to track, a new development is needed. Limits of size and weights have been reached in Europe and to meet analogous conditions there, the four-cylinder balanced compound has been developed into remarkably successful practice. The purpose of the Cole four-cylinder balanced compound is to advance American practice by adapting to our conditions the principles which have brought such advantageous results abroad, especially the principles of the de Glehn compound.

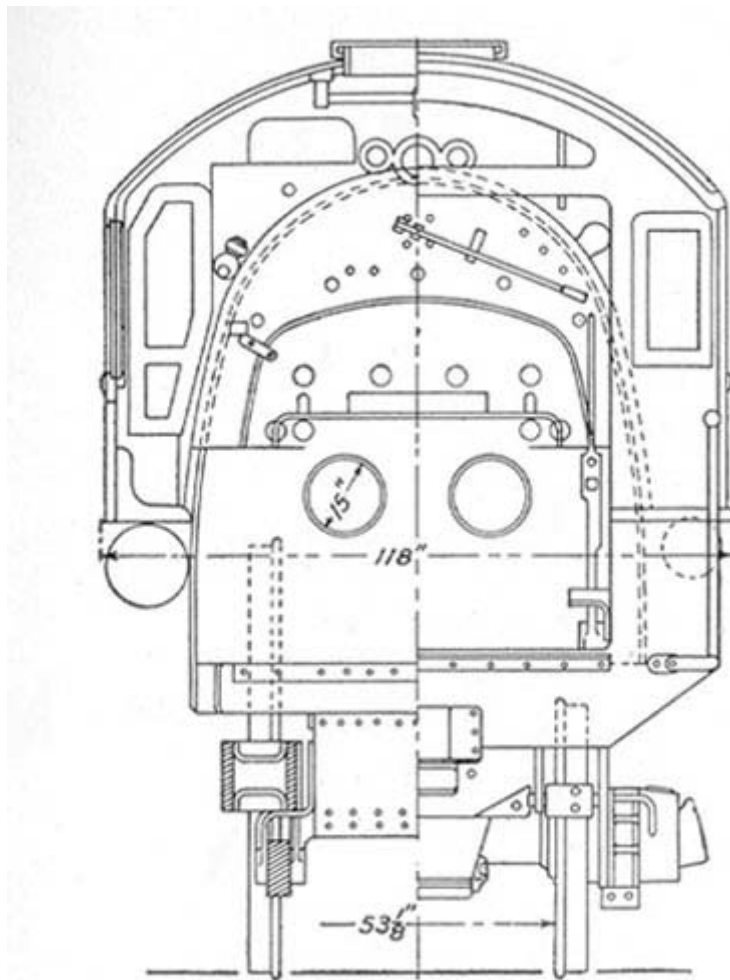

Fig. 16. Rear Elevation of the Cole Compound.

The Cole four-cylinder balanced compound employs the principle of subdivided power to the cylinders; the high pressure (between the frames) drives the forward or crank axle and the others; the low pressure (outside of the frames) drives the second driving axle. In order to secure a good length for connecting rods without lengthening the boiler, the high-pressure cylinders are located in advance of their usual position.

Special stress is laid on perfect balancing and the elimination of the usual unbalanced vertical component of the counterbalance stresses as a means for increasing the capacity, improving economy of operation and maintenance, and promoting good conditions of the track.

The relative positions of the high-pressure cylinder *A* and the low-pressure cylinder *B* may be seen in [Fig. 14](#) and [Fig. 15](#). The high-pressure guides, [Fig. 15](#), are located under and attach to the low-pressure saddle, whereas the low-pressure guides are in the usual location outside of the frames. The cranks of the driving wheels are 180 degrees apart. In order to equalize the weights of the pistons, those of the high-pressure cylinders are solid and those of the low-pressure cylinders are dished, and made as light as possible. A single valve motion, of the Stephenson type, operates a single valve stem on each side of the engine. Each valve stem carries two piston valves, one for the high- and the other for the low-pressure cylinder, as illustrated and explained later.

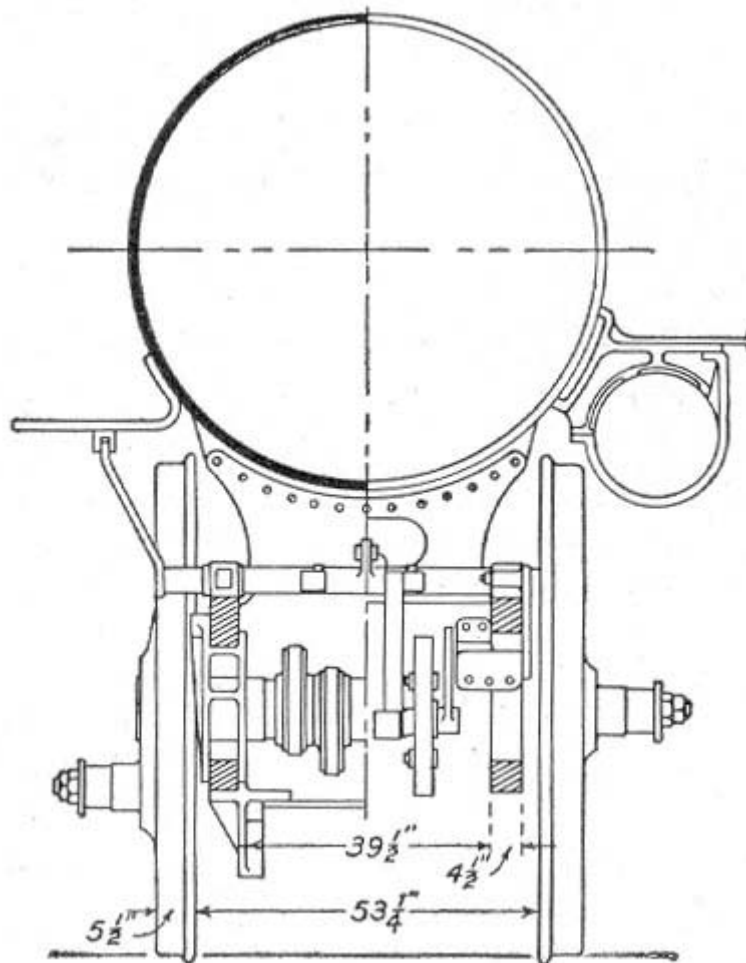

Fig. 17. Section of the Cole Compound.

The back end, [Fig. 16](#), and the two sections, [Fig. 17](#) and [Fig. 18](#), resemble ordinary construction of two-cylinder locomotives but the half front elevation and half section shown in [Fig. 19](#) disclose a number of departures. The high-pressure piston rod, crosshead, and the guides *C* are shown in position under the low-pressure saddle. The high-pressure cylinders *A* and the high-pressure section of the piston valve chamber *D* are all in one casting, [Fig. 20](#). The sides of the cylinder casting are faced off to the exact distance between the front plate extension of the frames. The valve chambers are in exact line with the valve chambers of the



low-pressure cylinder; intermediate thimble castings and packing glands being inserted between the two, form a continuous valve chamber common to both high- and low-pressure cylinders, thus providing for expansion.

*Fig. 21* shows the low-pressure cylinders *B* which are cast separately and bolted together. In this case the inside of the cylinders are faced off to proper dimensions to embrace the outer faces of the bar frame. The low-pressure piston valve chamber *F* is in direct line between the cylinder and the exhaust base *G*. This view illustrates the short direct exhaust passage *H* from the low-pressure cylinders to the exhaust nozzle.

*Fig. 22*, the crank axle, shows that under the existing conditions it is possible to make this part exceedingly strong. Inasmuch as the cranks on this axle are 90 degrees from one another, it is possible to introduce exceedingly strong 10 by 12½ inch rectangular sections connecting the two crank pins. The whole forms an exceedingly strong and durable arrangement constructed in accordance with the best European practice which is likely both to wear and stand up well in service. A cross-section of the central portion of the axle indicates its proportions between the crank pins.

The high- and low-pressure cylinders, *A* and *B*, are shown in *Fig. 23* as they would appear in section revolved into the same plane. The high-pressure valve *D* is arranged for central admission and the low-pressure valve *F* for central exhaust, both valves being hollow. A thimble casting or round joint ring and a gland connect the two parts of the continuous valve chamber *I*.

The following advantages of the four-cylinder balanced compound are claimed by the maker:

1. The approximately perfect balance of the reciprocating parts combined with the perfect balance of the revolving masses.
2. The permissible increase of weight on the driving wheels on account of the complete elimination of the hammer blow.
3. An increase in sustained horse-power at high speeds without modification of the boiler.
4. Economy of fuel and water.
5. The subdivision of power between the four cylinders and between the two axles, and the reduction of bending stress on the crank axle due to piston thrust because of this division of power.
6. The advantage of light moving parts which render them easily handled and which will minimize wear and repairs.
7. Simplicity of design One set of valve gears with comparatively few parts when compared with other designs which have duplicate sets of valve gears for similar locomotives.



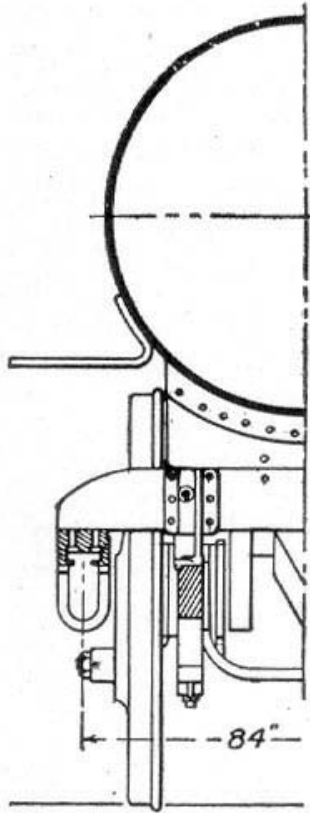

Fig. 18. Half-Section of the Cole Compound.

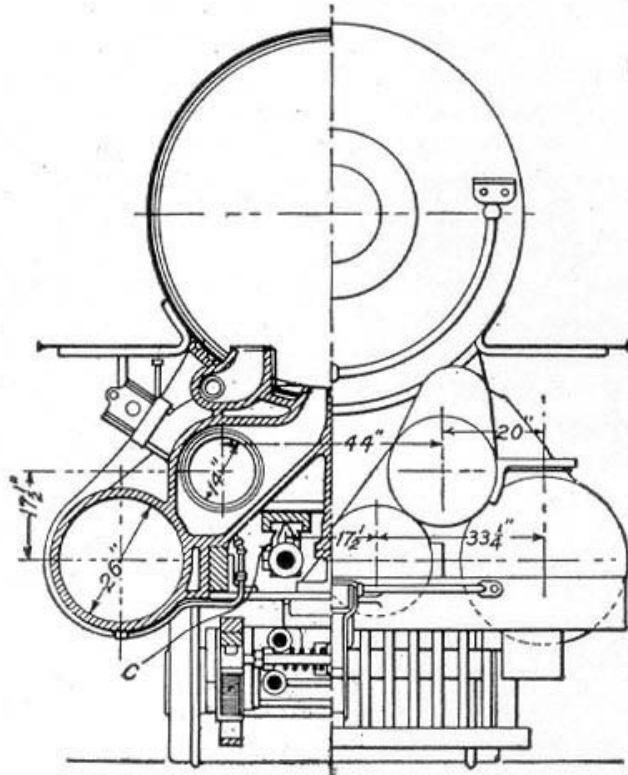

Fig. 19. Half Front Elevation and Half-Section.

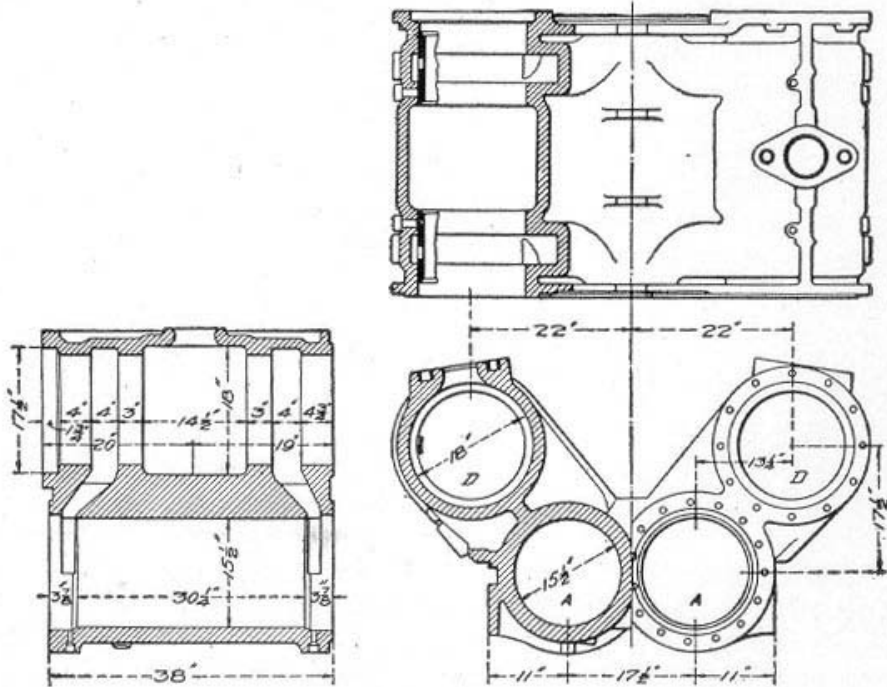

Fig. 20. Details of the Cylinders in the Cole Compound.



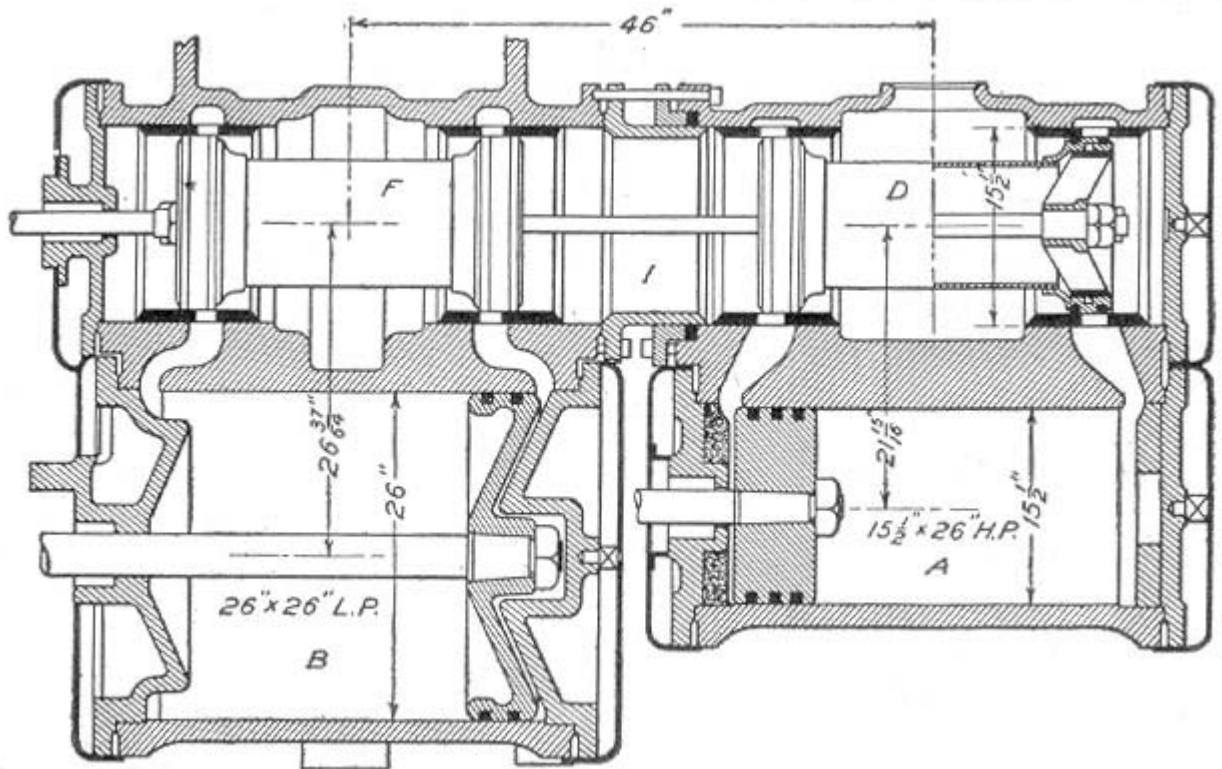

Fig. 23. Section of High- and Low-Pressure Cylinders Revolved into the Same Plane.

Another type of compound which is remarkable in many respects and which has had very successful usage in Europe is the *Mallet articulated compound*. It has been known and used in certain mountainous sections of Europe for several years but has recently been modified and adapted to meet American requirements. It is practically two separate locomotives combined in one, and advantage is taken of this opportunity to introduce the compound principles under the most favorable conditions. The following is a description together with dimensions of a large locomotive of this type built by the American Locomotive Company. Its enormous size is realized from [Fig. 24](#) and [Fig. 25](#). The weight of this particular locomotive in working order is nearly 335,000 pounds and the flues are 21 feet long. The rear three pairs of drivers are carried in frames rigidly attached to the boiler. To these frames, and to the boiler as well, are attached the high-pressure cylinders. The forward three pairs of drivers, however, are carried in frames which are not rigidly connected to the barrel of the boiler but which are in fact a truck. This truck swivels radially from a center pin located in advance of the high-pressure cylinder saddles. The weight of the forward end of the boiler is transmitted to the forward truck through the medium of side bearings, illustrated in [Fig. 24](#), between the second and third pair of drivers. In order to secure the proper distribution of weight, the back ends of the front frames are connected by vertical bolts with the front ends of the rear frames. These bolts are so arranged that they have a universal motion, top and bottom, which permits of a certain amount of play between the front and rear frames when the locomotive is rounding a curve. The low-pressure cylinders are attached to the forward truck frames.

The steam dome is placed directly over the high-pressure cylinders *A* from which steam is conducted down the outside of the boiler on either side to the high-pressure valve chamber. The steam after being used in the high-pressure cylinders *A* passes to a jointed

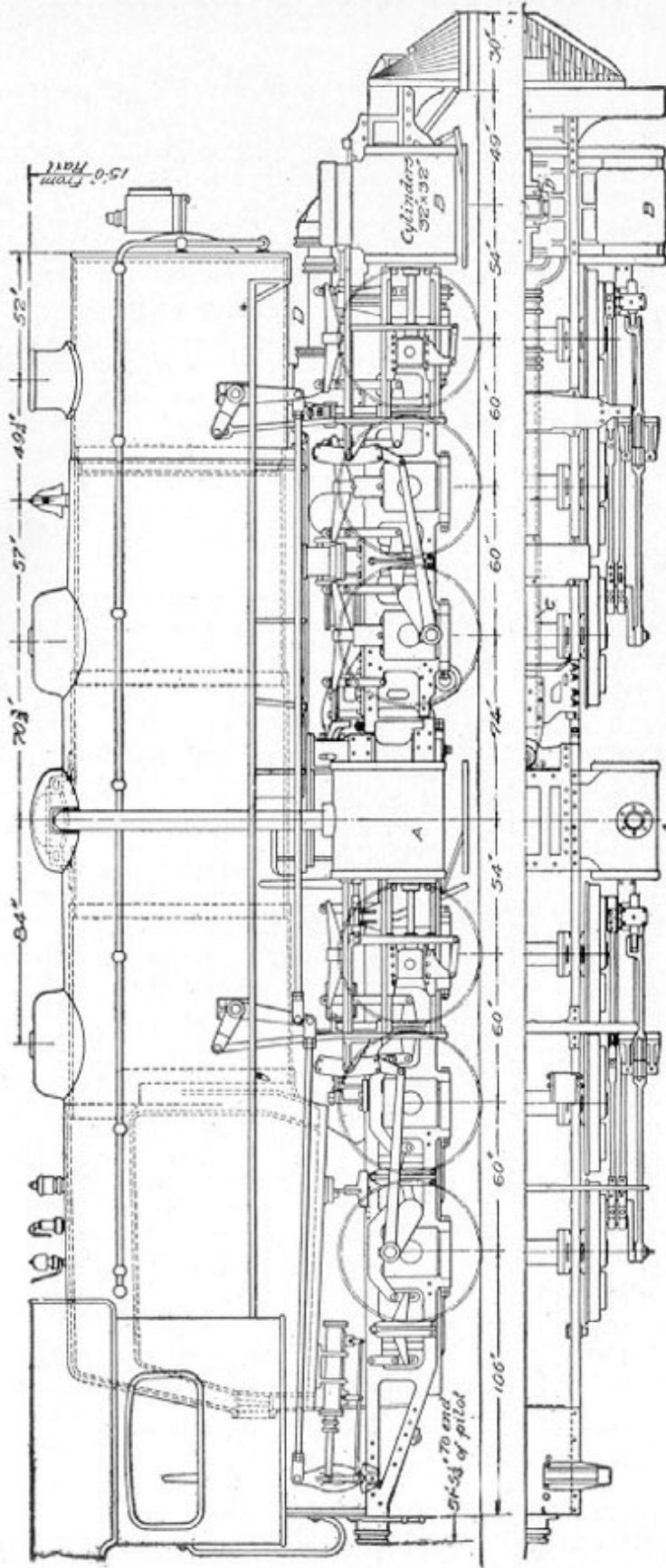
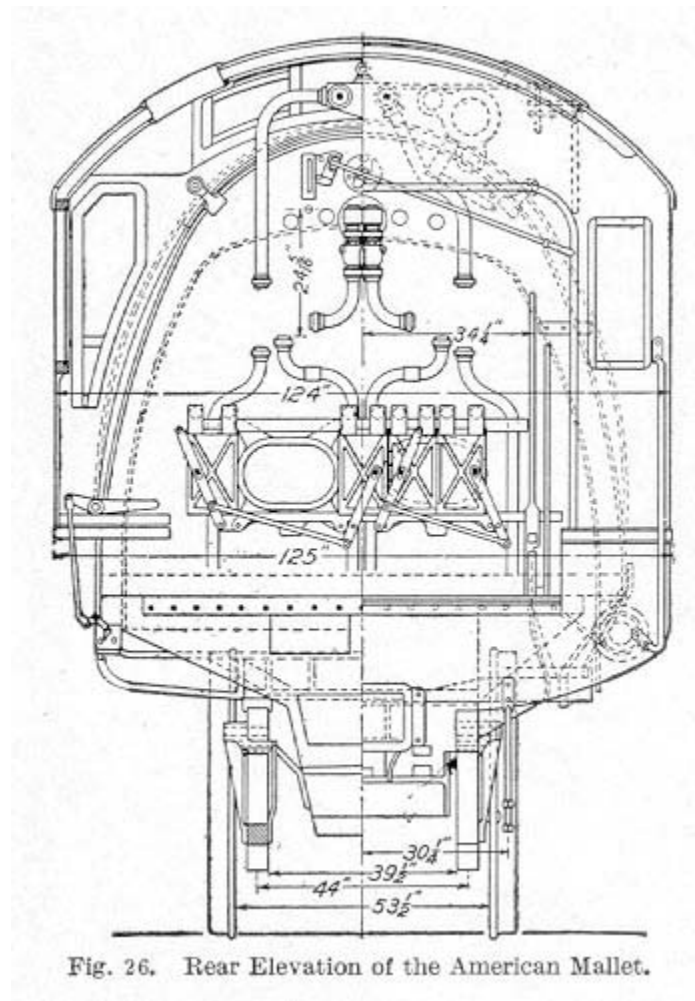

Fig. 24. Elevation of American Model of Mallet Articulated Compound.  
 Fig. 25. Half-Plan of the Same.

pipe *C* between the frames and is delivered to the low-pressure cylinders *B*, whence it is exhausted by a jointed pipe *D* through the stack in the usual way. The back end, [Fig. 26](#), presents no unusual feature other than the great size of the boiler and fire-box. The section shown in [Fig. 27](#) illustrates the method of bringing the steam down from the steam dome to the high-pressure valve *E*. The section in [Fig. 28](#) clearly shows the sliding



support *F* between the boiler and front truck. It also shows the method of attaching the lift shafts to the boiler barrel which is made necessary by the use of the Walschaert valve gear. [Fig. 29](#) shows that the low-pressure cylinders *B* are fitted with slide valves, and also shows the jointed exhaust pipe from the low-pressure cylinder to the bottom of the smoke-box. [Fig. 30](#) illustrates the construction and arrangement of the flexible pipe connection *C* between the high-pressure cylinder *A* and the low-pressure cylinder *B*. This pipe connection, as well as the exhaust connection *D* between the low-pressure cylinder and the smoke stack, serves as a receiver. The ball joints are ground in, the construction being such that the gland may be tightened without gripping the ball joint.

The builders claim for this design about the same advantages over the simple engine as were enumerated in the description of the Cole four-cylinder balanced compound. It is evident that the Mallet compound is a large unit and hence can deliver more power with the same effort of the crew. A reserve power of about 20 per cent above the normal capacity of the locomotive may be obtained by turning live steam into all four cylinders



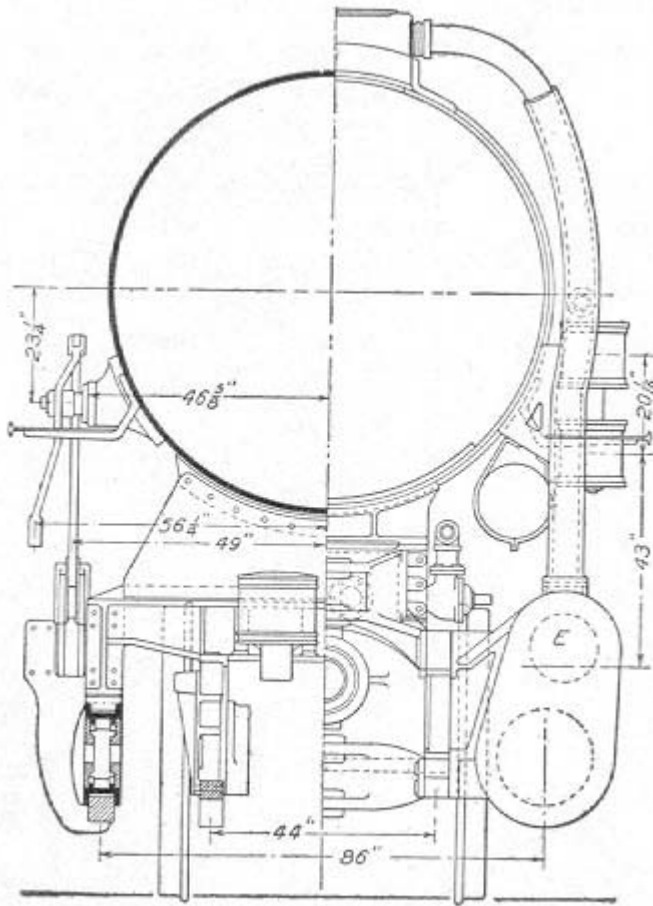

Fig. 27. Section of American Mallet Showing Method of Bringing Steam from Dome to High-Pressure Cylinder.

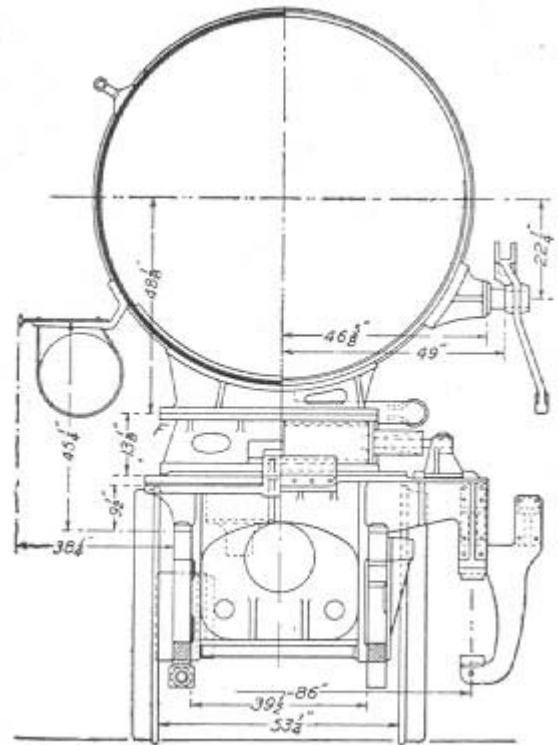

Fig. 28. Section of American Mallet.

and running the locomotive simple which can be done at the will of the engineer when circumstances demand it.

The diagrammatic illustration shown in [Fig. 31](#) presents a good means of studying and comparing the four different types of compound locomotives referred to in the preceding pages. Briefly stated, the essentials in each of the four cases illustrated are as follows:

*Cole.* High-pressure cylinders, inside but in advance of the smoke-box, driving front axle. Low-pressure cylinders, outside in line with the smoke-box, driving rear driving axle. Two piston valves on a single stem serve the steam distribution for each pair of cylinders, and each valve stem is worked from an ordinary link motion.

*Vauclain.* High-pressure cylinders inside and low-pressure cylinders outside, all on the same horizontal plane, in line with the smokebox and all driving the front driving axle. As in the von Borries, a single piston valve worked from a single link effects the steam distribution for the pair of cylinders on each side.

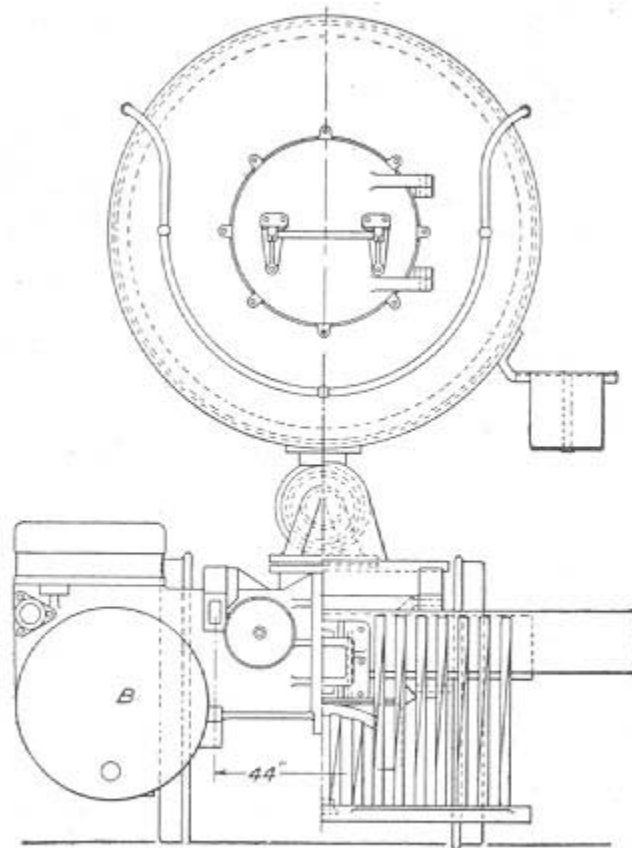

Fig. 29. Forward Half-Section Showing Slide Valves in the Low-Pressure Cylinders.

*De Glehn.* High-pressure cylinders, outside and behind smoke-box, driving the rear drivers. Low-pressure cylinders, inside under smoke-box, driving crank axle of front drivers. Four separate slide valves and four Walschaert valve gears allowing independent regulation of the high- and low-pressure valves.

*Von Borries.* High-pressure cylinders inside and low-pressure cylinders outside all on the same horizontal plane in line with the smoke-box and all driving the front driving axle. Each cylinder has its own valve but the two valves of each pair of cylinders are worked from a single valve motion of a modified Walschaert type. This arrangement permits the varying of the cut-off of the two cylinders giving different ratios of expansion which cannot, however, be varied by the engine-man.

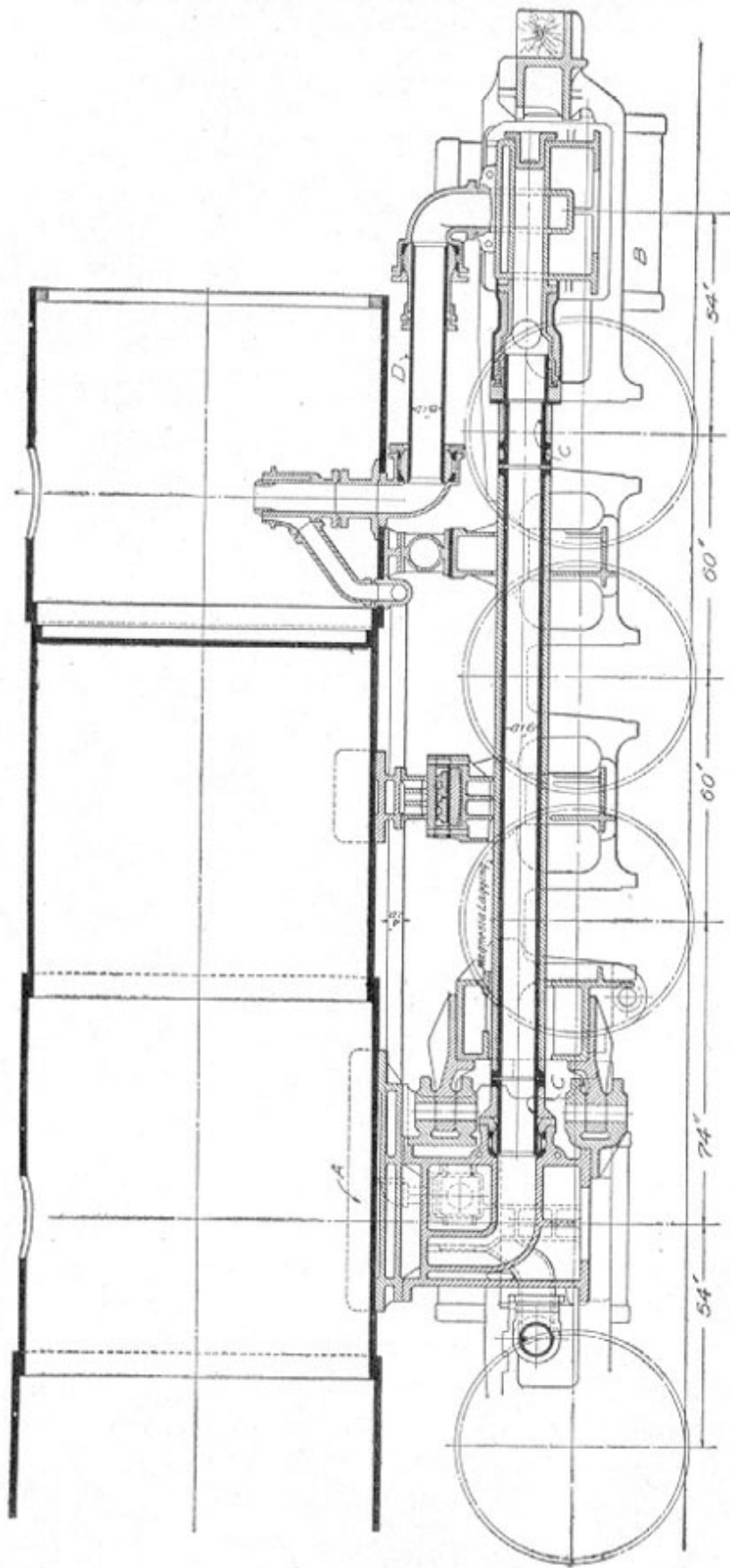

Fig. 30. Longitudinal Section of American Mallet Showing Flexible Pipe Connection Between High- and Low-Pressure Cylinders.



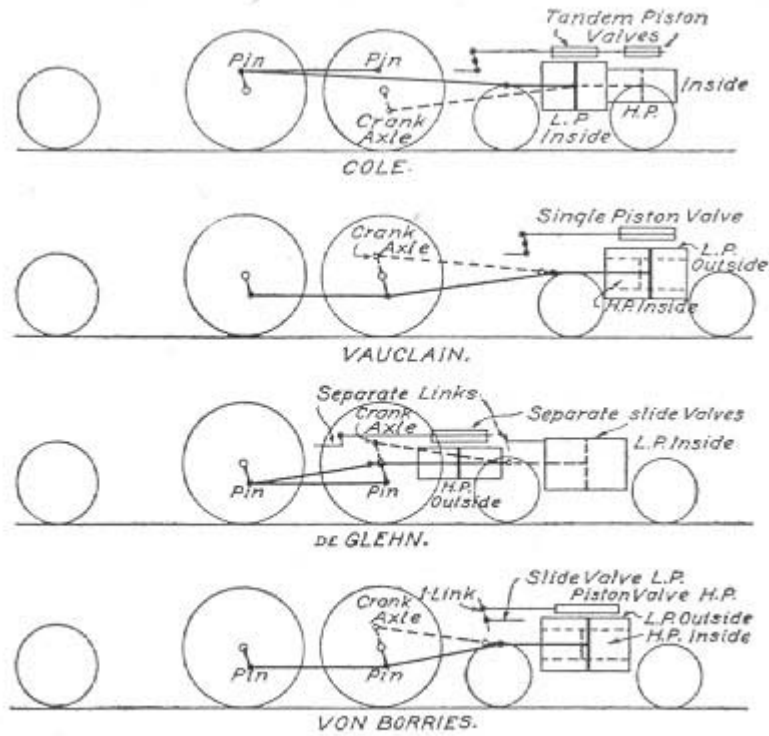

Fig. 31. Diagrams Showing Variations in the Four Principal Types of Compounds.

In addition to the compound locomotives already described, an early development of this type, known as the *Richmond*, or cross-compound, came into service. This engine differs from those already described in that it has only two cylinders, whereas those previously mentioned have four. In the cross-compound engine there is a high-pressure cylinder on the left side and a large or low-pressure cylinder on the right. The live steam passes from the boiler through the head and branch pipes to the high-pressure cylinder in the usual way. It is then exhausted into a receiver or circular pipe resembling the branch pipe which conveys the steam from the high-pressure cylinder across the inside of the smoke-box into the steam chest of the low-pressure cylinder. The steam passes from the steam chest into the cylinder and exhausts out through the stack in the usual way. The construction is such that the locomotive can be worked simple when starting trains. This type was never very largely used.

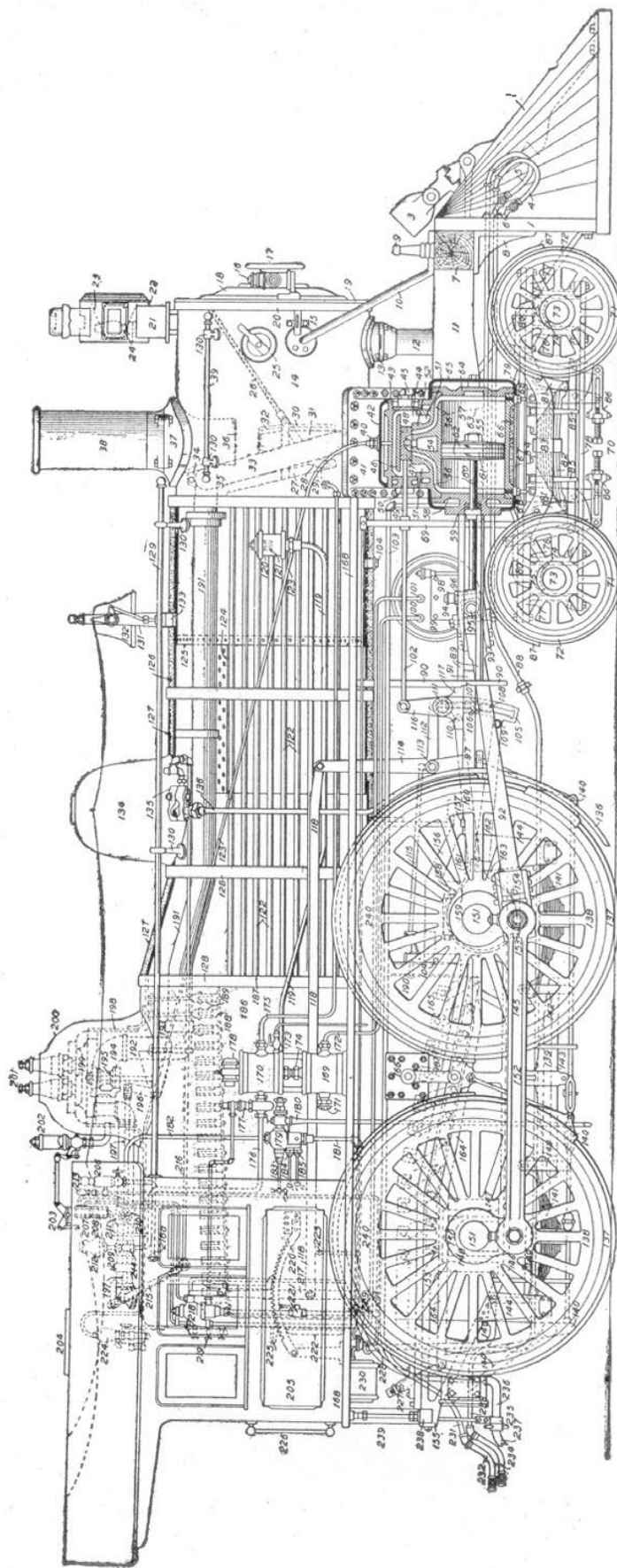

Fig. 32. Longitudinal Section of the American Locomotive.

Fig. 32. Longitudinal Section of the American Locomotive.

1-Pilot. 2-Draw Head Attachment. 3-Folding Draw Head. 4-Air Signal Hose. 5-Air Brake Hose. 6-Hose Hangers. 7-Buffer Beam. 8-Pilot Bracket. 9-Flagstaff. 10-Arch Brace. 11-Front Frame. 12-Cinder Chute. 13-Cinder Chute Slide. 14-Extension Front. 15-Headlight Front. 16-Signal Lamp. 17-Number Plate. 18-Smoke Arch Door. 19-Smoke Arch Front. 20-Smoke Arch Ring. 21-Headlight Bracket. 22-Headlight Case. 23-Headlight Reflector, 24-Headlight Burner. 25-Cleaning Door. 26-Netting. 27-Deflector Plate. 28-Deflector Plate Adjuster. 29-Air Pump Exhaust Pipe. 30-Blower. 31-Nozzle Stand. 32-Nozzle Tip. 33-Steam Pipe (2). 34-T or Nigger Head. 38-Dry Pipe Joint. 36-Petticoat or Draft Pipe. 37-Stack Base. 38-Smoke Stack. 39-Arch Hand Kail. 40-Oil Pipe Plug. 41-Cylinder Saddle. 42-Steam Chest Casing Cover. 43-Steam Chest Cover. 44-Steam Chest. 45-Relief Valve. 46-Balance Plate. 47-Balanced Valve. 48-Valve Yoke. 49-Valve Stem. 50-Valve Stem Packing. 51-Steam Passages to Chest. 52-Valve Seat. 53-Bridges. 54-Exhaust Port. 55-Piston Rod Nut. 56-Steam Ports. 57-Cylinder. 58-Back Cylinder Head. 69-Piston Rod Packing. 60-Piston Rod. 61-Piston Head. 62-Piston Packing Rings. 63-Truck Center Castings. 64-Front Cylinder Head. 65-Cylinder Head Casing. 66-Cylinder Lagging. 67-Cylinder Casing. 68-Cylinder Cocks. 69-Cylinder Cock Rigging. 70-Engine Track Wheel. 71-Engine Truck. 72-Engine Truck Tire. 73-Engine Truck Axle. 74-Engine Truck Brass. 75-Engine Truck Box. 76-Engine Truck Pedestal. 77-Engine Truck Frame. 78-Engine Truck Pedestal Brace. 79-Engine Truck Frame Brace. 80-Engine Truck Equalizer. 81-Engine Truck Spring Hanger. 82-Engine Truck Spring. 83-Engine Truck Spring Band. 84-Engine Truck Spring Pocket. 85-Safety Hanger. 86-Truck Brake. 87-Wheel Guard. 88-Signal Pipe. 89-Guides. 90-Guide Yoke. 91-Guide Block. 92-Main Rod, 93-Main Rod Front Strap. 94-Key. 95-Crosshead Pin. 95-Crosshead. 97-Main Frame. 98-Air Drum Bracket. 99-Air Drum. 100-Pump Connection. 101-Train Pipe Connection. 102-Valve Stem Rod. 103-Train Pipe. 104-Wash Out Plugs. 105-Link. 106-Suspension Stud. 107-Link Block Pin. 108-Link Block. 109-Eccentric Connection, Back Up. 110-Eccentric Connection, Go Ahead. 111-Link Hanger. 112-Tumbling Shaft Arm. 113-Tumbling Shaft. 114-Tumbling Shaft Lever. 115-Counterbalance Spring and Rig. 116-Rocker. 117-Rocker Box. 118-Reach Rod. 119-Branch Pipe. 120-Check Valve Case. 121-Check Valve. 122-Flues. 123-Oil Pipe. 124-Horizontal Boiler Seam. 125-Circumferential Seam. 126-Boiler Lagging. 127-Boiler Jacket. 128-Jacket Bands. 129-Hand Rail. 130-Hand Rail Brackets. 131-Bell Stand. 132-Bell. 133-Steam Bell Ringer. 134-Sand Box. 135-Pneumatic Sander. 136-Sand Pipe. 137-Driving Wheel Tire. 138-Driving Wheel Centers. 139-Ash Pan. 140-Driver Brakes. 141-Driver Springs. 142-Driver Spring Hangers. 143-Driver Spring Equalizers. 144-Driver Spring Hanger Brace. 145-Lower Rail of Frame. 146-Pedestal Brace. 147-Driving Box Shoe. 148-Driving Box Wedge. 149-Wedge Bolt. 150-Driving Box. 115-Driving Axle. 152-Side or Parallel Rod. 153-Rod Bush. 154-Main Rod Connection, 155-Main Frame. 156-Frame Brace. 157-Frame Splice. 158-Go Ahead Eccentric. 159-Back-Up Eccentric. 160-Go Ahead Eccentric Rod. 161-Go Ahead Eccentric Strap. 162-Back-Up Eccentric Rod. 163-Back-Up Eccentric Strap. 164-Grate Shaking Rig. 165-Rocking Grates. 166-expansion Pad. 167-Expansion Link. 168-Running Board. 169-Air Cylinder Brake Pump. 170-Steam Cylinder Brake Pump. 171-Air Strainer. 172-Delivery to Drum. 173-Drip Cock. 174-Pump Piston Packing. 175-Pump Exhaust Connection. 176-Pump Steam Connection. 177-Governor. 178-Pump Valve Case. 179-Injector. 180-Injector Overflow. 181-Water Pipe. 182-Steam Pipe. 183- Steam Valve. 184-Primer. 185-Water Valve. 186-Fire Box, 187-Tube Sheet. 188-Crown Bars. 189-Sling Stays. 190-Stay Bolts. 191-Dry Pipe. 192-Stand Pipe. 193-Dry Pipe Hangers. 194-Throttle Pipe. 195-Throttle Valve. 196-Throttle Bell Crank. 197-Throttle Stem. 198-Dome. 199-Dome Cap. 200-Dome Casing. 201-Safety Valves. 202-Chime Whistles. 203-Whistle Rig. 204-Ventilator 205-Cab. 206-Air Pump Lubricator. 207-Air Gauge. 208-Steam Gauge. 209-Steam Turret. 210-Injector Throttle. 211-Blower Cock. 212-Gauge Lamp. 213-Signal Whistle. 214-Air Pump Throttle. 215-Throttle Lever. 216-Pneumatic Sander, 216a-Sand Lever. 217-Reverse Lever. 218-Engineer's Brake Valve. 219-Gauge Cocks. 220-Quadrant. 221-Cut Out Valve. 222-Fire Door. 223-Cylinder Cock Lever. 224-Cylinder Lubricator. 225-Oil Can Shelf. 226-Hand Hold. 227-Shake Lever Stub. 228-Ash Pan Damper Handle. 229-Whistle Signal Valve. 230-Brake Valve Reservoir. 231-Train Pipe. 232-Train Pipe Hose. 233-Signal Pipe 234-Signal Pipe Hose. 235-Feed Pipe Hanger. 236-Feed Pipe. 237-Feed Pipe Hose. 238-Tall Piece of Frame. 239-Cab Bracket 240-Counterbalance Weight.

# ACTION OF STEAM IN OPERATING LOCOMOTIVE

**General Course of Steam.** One of the most important features in locomotive operation is the action of the steam in transmitting the heat energy liberated in the fire-box to the driving wheels in the form of mechanical energy. It is therefore important that we should have a clear understanding, in the beginning, of the various changes which occur while the steam is passing from the boiler to the atmosphere in performing its different functions. In making this study it will prove of much assistance if reference is made to [Fig. 32.](#) (See [page 27](#) for figure and associated index).

Before this is done, however, a brief statement of the characteristics of steam and the precautions which must be taken as the steam passes through the cylinder may not be out of place. At normal pressure water boils at 212° F., but with an increase of pressure the boiling temperature and the consequent temperature of the steam rises. Now if the steam formed at 212° F. and atmospheric pressure were passed into the cool steam chest and later into the cylinder, it would become cooled below 212° F., would condense, and would therefore lose its power. To avoid this possibility, the steam is generated in the boiler at a high pressure so that, when allowed to expand into the cylinder and lose some of its energy by virtue of the work it has done on the piston, the temperature is still *above* the condensation temperature for the pressure under which it is acting.

With this in mind let us follow the steam in its path and note the changes to which it is subject and the direct results of its action. When the throttle is opened the steam, which is generated in the boiler and there held at high pressure, enters the dry pipe at a point near the top of the dome and flows forward to the smokebox, where it enters the T-head and is conducted downward on either side into the steam chest and ultimately through the cylinders and out through the exhaust to the atmosphere.

**Steam Enters Steam Chest.** At the very outset when the throttle valve is opened and steam enters the dry pipe, a change takes place. This change is a loss in pressure; for when the steam reaches the steam chest its pressure is reduced several pounds per square inch, as evidenced by gages placed on the boiler and steam chest or by steam chest diagrams taken simultaneously with the regular cylinder diagrams. This pressure drop would not appear were it not for the fact that the locomotive is set into motion at the opening of the throttle. Consequently, motion is transmitted to the steam in the various pipes and passages, and the frictional resistance offered retards its flow, with the result that a pressure less than that in the boiler is maintained. The exact amount of this pressure drop depends upon the throttle opening and the rate at which steam is drawn off. This latter feature is a function of the engine speed, which in a measure depends upon the opening of the throttle. Under all conditions, so long as the locomotive is in motion, the pressure in the steam chest will be less than that in the boiler.

**Steam Enters Cylinder.** The steam, after reaching the steam chest, is admitted alternately to first one end of the cylinder then the other through the action of the valve. The opening and closing of the valve is a continuous process, the amount of opening increasing from zero to a maximum and then decreasing to zero. Because of this fact there will be two periods of wire drawing during each admission, independent of the fact that there may or may not be wire drawing during the period of maximum opening. This

action causes a further drop in pressure when the steam finally gets into the cylinder, which loss increases with the speed of the engine.

**Steam in Cylinder.** After the steam reaches the cylinder it experiences a still further loss caused by condensation due to the comparatively cool cylinder walls, heads, and piston. This loss can be minimized to a limited extent by the use of an efficient lagging but it can never be entirely eliminated. Even if there were no loss in the cylinder due to radiation, there still would be a loss because of the exhaust, which occurs at a temperature much lower than that of the entering steam and which would cool the cylinder walls and parts to at least the average temperature of the steam in the cylinder during the stroke.

When the steam expands in the cylinder in the performance of its work still another drop in pressure occurs, the amount depending upon the point of cut-off. As this can be varied at the will of the operator, it can be seen that the pressure drop can be very great or very small. During this portion of its travel the steam does its first useful work since leaving the boiler. The steam while in the steam chest exerts a pressure on the valve which causes friction and thereby absorbs a portion of the useful work generated by the action of the steam on the piston.

The steam acting on the piston and causing it to move produces rotation of the driving wheels through the medium of the connecting rod, crank-pin, and various other parts, with an effort which varies throughout the stroke owing to the expansion of the steam, the exhaust and compression, which is taking place on the opposite side of the piston, and the angularity of the connecting rod. The pressure on the guides, due to the angularity of the connecting rod, causes friction which reduces the effectiveness of the work done on the piston. The effect of the inertia of the parts at high rotative speeds affects the thrust on the crank-pin to a marked degree. These points and many others which might be mentioned are of much importance in the study of the locomotive and its ability to do useful work in hauling trains.

**Steam after Leaving Cylinder.** The steam having pushed the piston to the end of its stroke is exhausted on the return stroke, but at a slight back pressure, which opposes the effectiveness of the return stroke and results in a direct loss. The closing of the valve before the completion of the return stroke causes an additional resistance in compressing the steam remaining in the cylinder, but this is not without some advantage. The steam in being exhausted from the cylinder is discharged into the exhaust cavity in the cylinder and from thence into the exhaust passage in the cylinder saddle and out through the exhaust nozzle into the smoke-box. At this point the steam is very much reduced in pressure but, owing to its relatively high velocity, as it leaves the exhaust nozzle and enters the stack, it is still able to do useful work by producing a slight vacuum in the smoke-box in an ejector-like action. The useful work performed is not in the way of moving the machine but in increasing the rate of combustion in the fire-box. The action is such as to cause a rate of combustion unequalled in any other form of steam power plant with the exception, perhaps, of the steam fire engine which a few years ago was so popular.

# LOCOMOTIVE BOILERS

Before entering into the details of the various elements comprising a locomotive, it is thought advisable to give them some study in order to become familiar with the names of the various parts and their relation to each other. [Fig. 32](#) (See [page 27](#) for figure and associated index) is given for this purpose and represents a longitudinal section of a 440 type locomotive with all parts numbered and named. This figure should be carefully studied in order that the future work of the text may be clearly understood.

A *locomotive boiler* may be defined as a steel shell containing water which is converted into steam, by the heat of the fire in the firebox, to furnish energy to move the locomotive.

Locomotive boilers are of the internal fire-box, straight fire-tube type having a cylindrical shell containing the flues and an enlarged back-end for the fire-box, and an extension front-end or smoke-box leading out from which is the stack.

**Classification of Boilers as to Form.** Locomotive boilers are classified as to form as follows:

*Straight top*, [Fig. 33](#), which has a cylindrical shell of uniform diameter from the fire-box to the smoke-box.

*Wagon top*, [Fig. 34](#), which has a conical or sloping course of plates next to the fire-box and tapering down to the circular courses.

*Extended wagon top*, [Fig. 35](#), which has one or more circular courses between the fire-box and the sloping courses which taper to the diameter of the main shell.

**Classification of Boilers as to Fire-Box Used.** Boilers are frequently referred to also and designated by the type of fire-box contained, such as *Belpaire*, *Wooten*, and *Vanderbilt*. This designation does not in any way conflict with the classification of different types of boilers already given but refers to the general character of the fire-box; that is, the boiler may be classified as a straight top boiler and at the same time a Wooten fire-box. Since this is true it is necessary to know the distinction between the Belpaire, the Wooten, and the Vanderbilt types of fire-box.

The *Belpaire boiler*, as illustrated in [Fig. 36](#), has a fire-box with a flat crown sheet *A* jointed to the side sheets *B* by a curve of short radius. The outside sheet *C* and the upper part of the outside sheets *D* are flat and parallel to those of the fire-box. These flat parallel plates are stayed by vertical and transverse stays and obviate the necessity of crown bars to support and strengthen the crown sheet. The advantage gained is that the stay bolts holding the crown and side sheets can be placed at right angles to the sheets into which they are screwed.

The *Vanderbilt fire-box* is built of corrugated forms, as illustrated in [Fig. 37](#). The principal object in the design of this fire-box is to eliminate stay bolts which are a source of much trouble and expense in keeping up repairs. Only a few locomotives fitted with this type of fire-box have been used.

The *Wooten fire-box*, so-called, obtained its name from the designer. This form of fire-box extends out over the frames and driving wheels, as may be seen from [Fig. 38](#). It was designed for the purpose of burning fine anthracite coal but soon after its introduction it found favor with a few railroads using bituminous coal. The drawing shown in [Fig. 39](#)

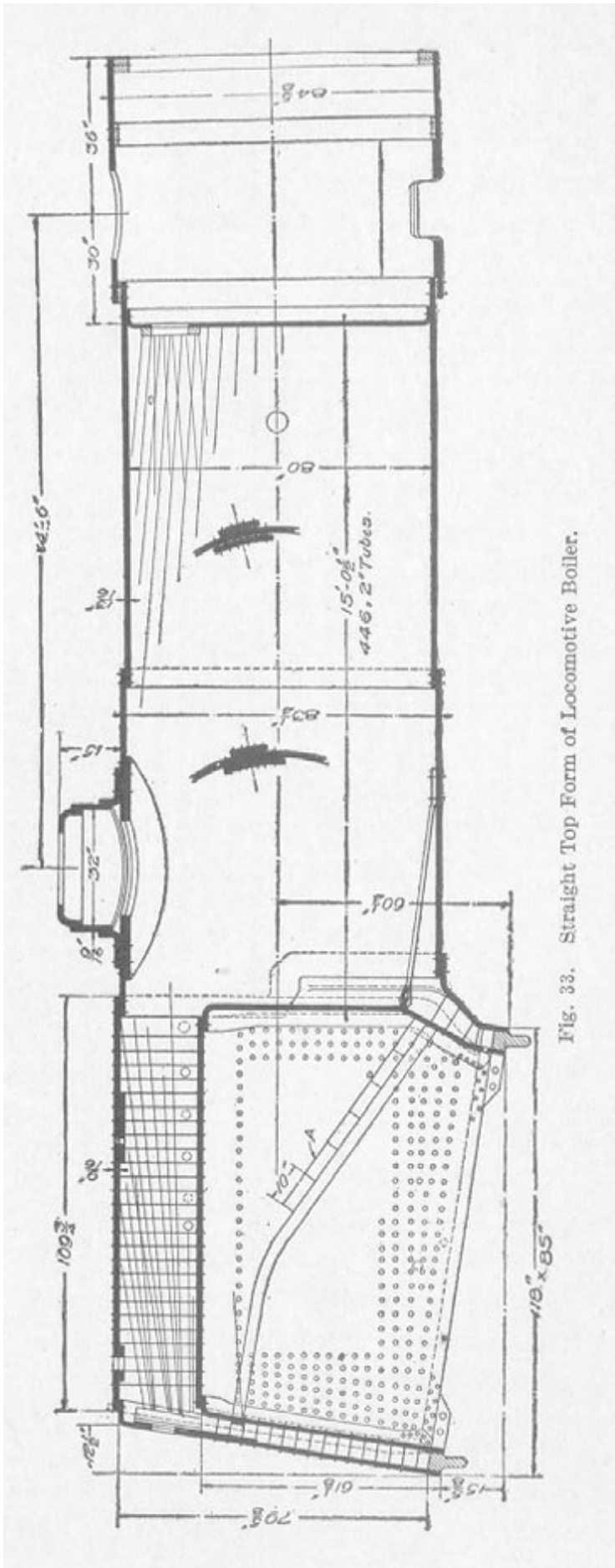

Fig. 33. Straight Top Form of Locomotive Boiler.

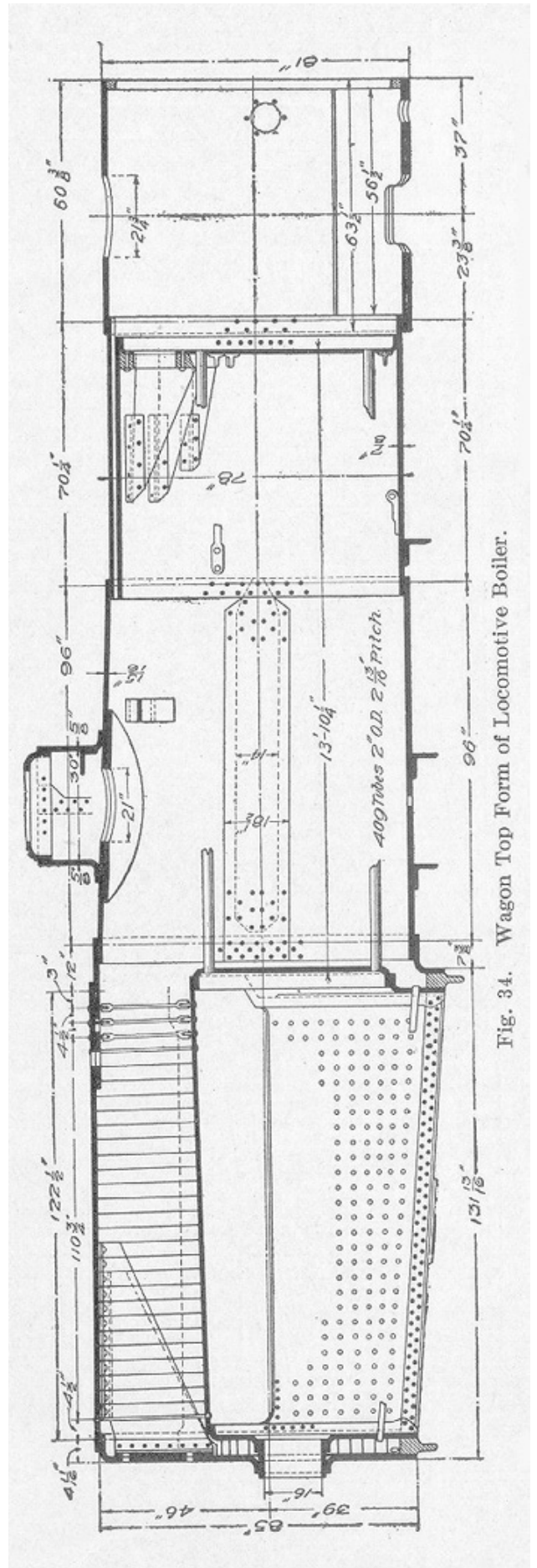

Fig. 34. Wagon Top Form of Locomotive Boiler.



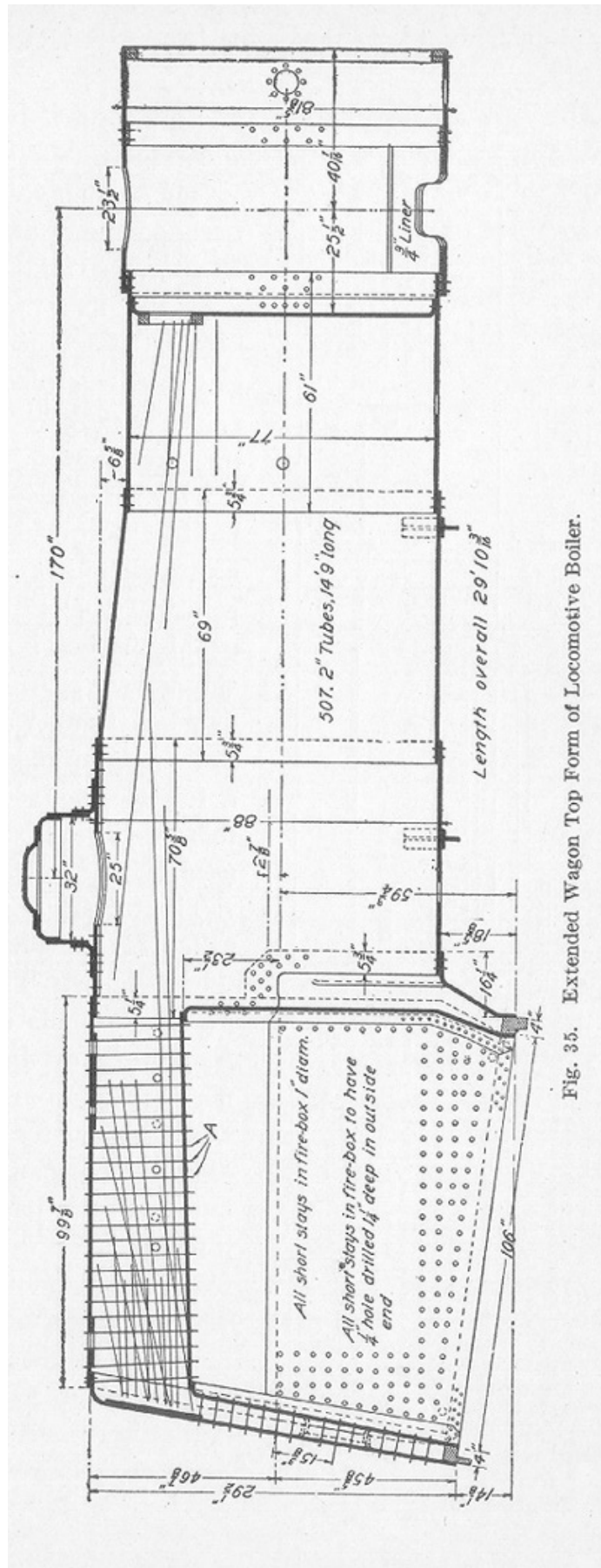

Fig. 35. Extended Wagon Top Form of Locomotive Boiler.





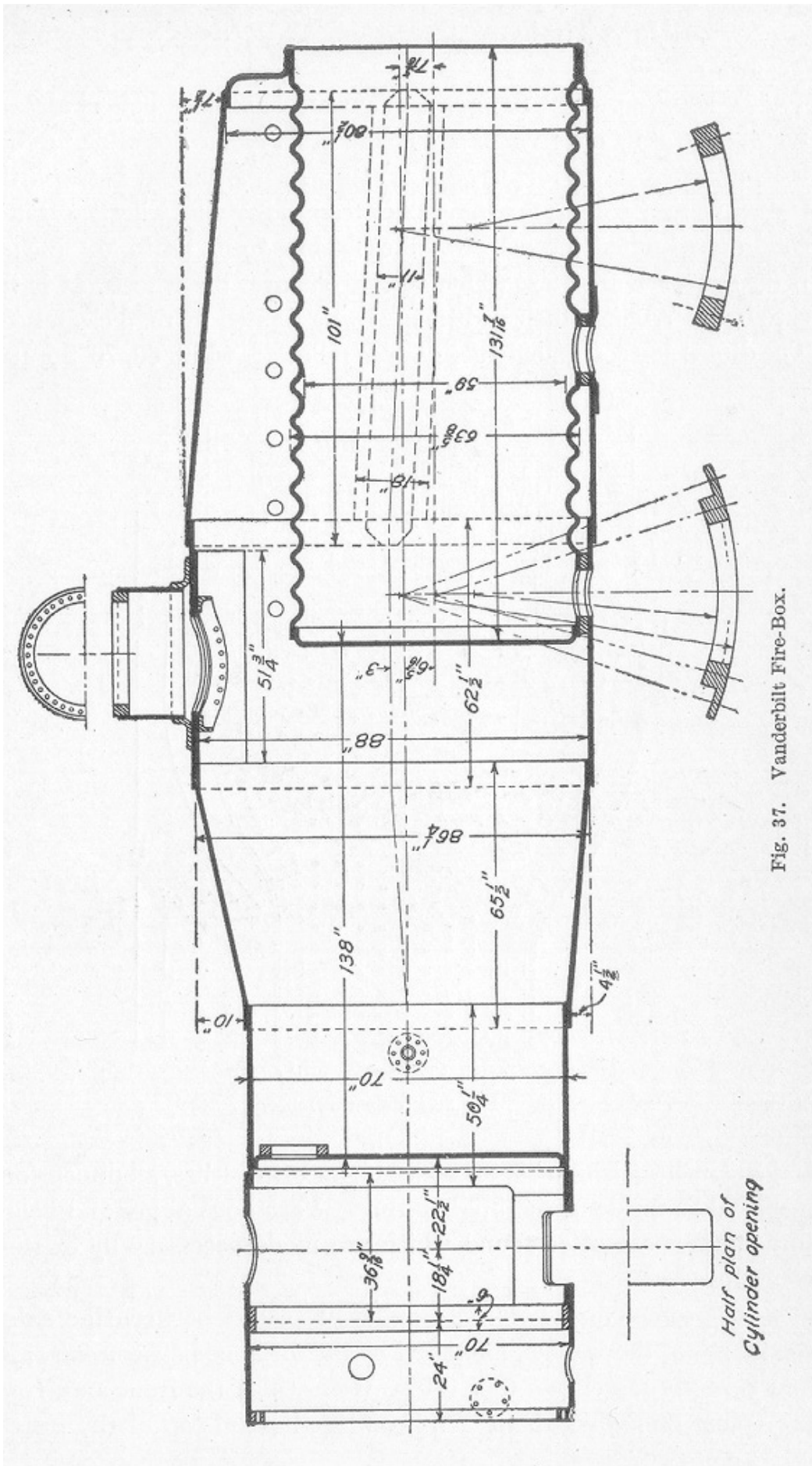

Fig. 37. Vanderbilt Fire-Box.

illustrates its general construction. It has rendered good service in certain localities but has never been very extensively used. In addition to the designations given the various boilers already mentioned, they are frequently spoken of as narrow or wide fire-box locomotives. A *narrow fire-box* is one which is placed between the frames or may rest on the frames between the driving wheels. These conditions limited the width of the fire-box from 34 to 42 inches. *Wide fireboxes* are those which extend out over the wheels, as is the

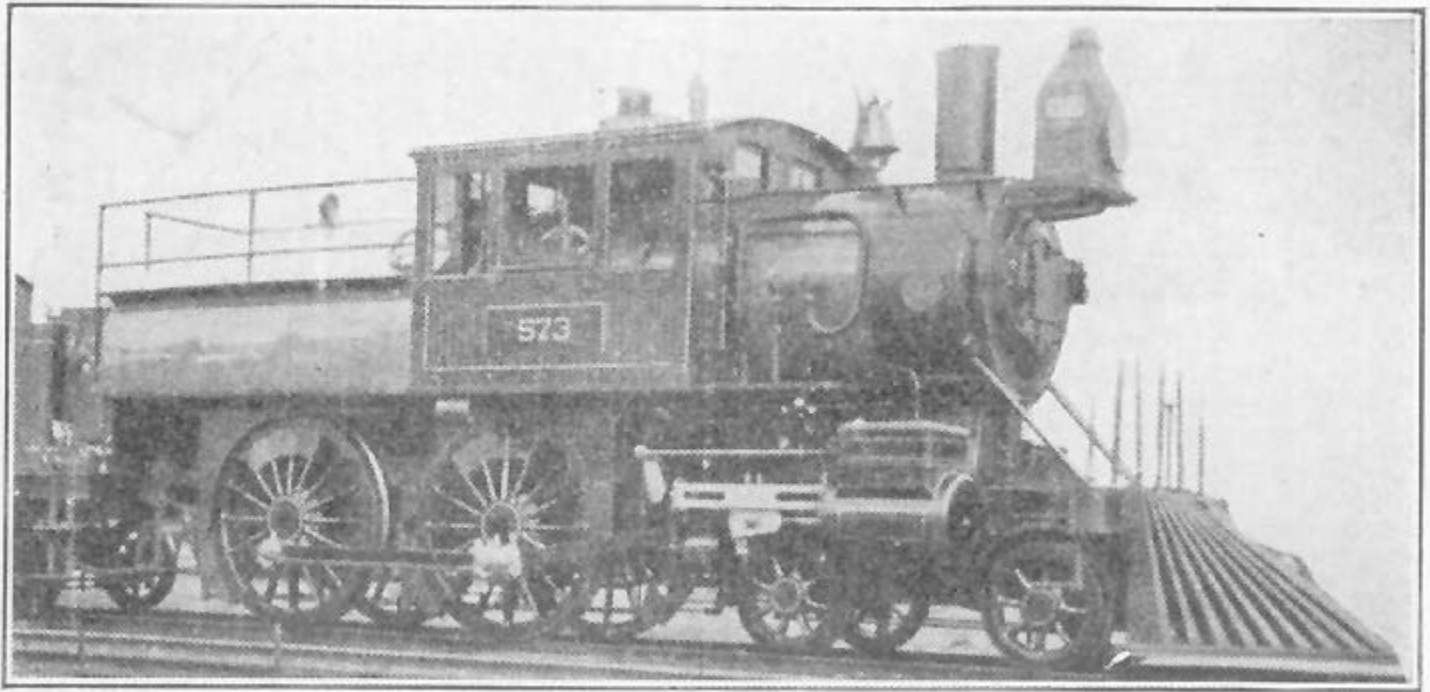

Fig. 38. Engine with Wooten Fire-Box.

case in the Wooten, their width only being limited by road clearances. The dimensions commonly used are as follows: width 66, 76, 85, 103, and 109 inches; length 85, 97, 103, 115, and 121 inches, all dimensions being taken inside of the fire-box ring. Variations above and below these figures are often found which are made necessary by existing conditions.

In locomotives where the fire-box is placed between the axles, the length of the fire-box is limited by the distance between the axles and is rarely more than 6 or 9 feet, from which the front and back legs must be deducted. Placing the fire-box on top of the frames makes any length possible, the length being governed by the capability of the fireman to throw the coal to the front end of the fire-box.

**Flues.** From the sectional view of the boiler illustrated in [Fig. 32](#) (See [page 27](#) for figure and associated index) and [Fig. 44](#), it is evident that a large part of the boiler is composed of flues or tubes. The flues give to the boiler the largest part of its heating surface. It is the flues which largely affect the life of the boiler and, therefore, the life of the locomotive, for this reason it is quite necessary to properly install and maintain them. A large amount of the repair costs is directly traceable to the flues. This is especially true in localities where water is found which causes scale to form on the flues from 1/16 to 1/2 inch in thickness, thus causing unequal expansion and contraction and overheating. These

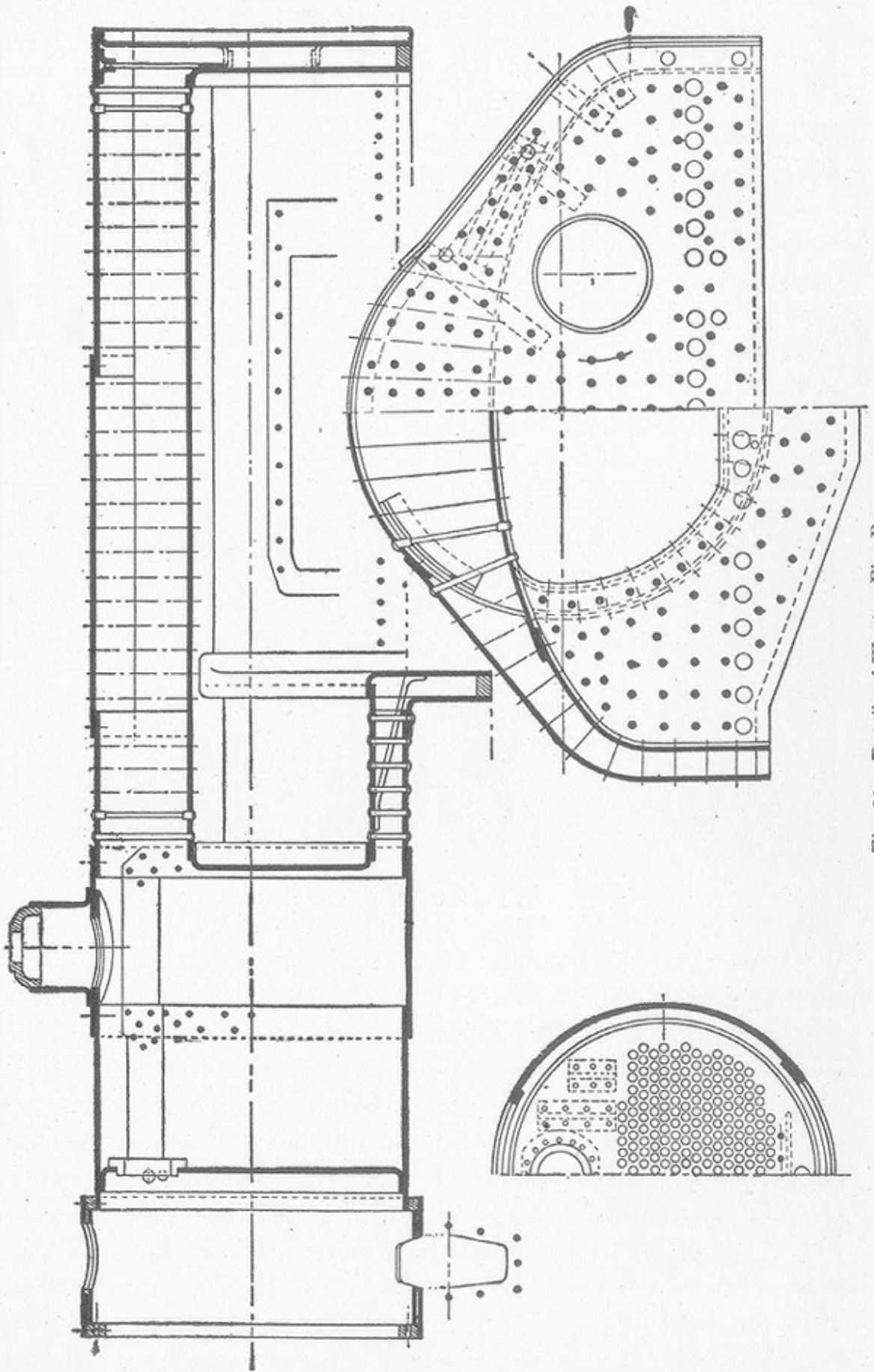

Fig. 39. Details of Wooten Fire-Box.



conditions cause the joints to break at the flue sheets. Cold air entering the fire-box door is another source of flue trouble. It is to these details that careful attention must be given in order to alleviate flue failures. Flues should be made of the best quality of charcoal iron, lap-welded, and subjected to severe tests before being used. They must be accurately made, perfectly round and smooth, must fill standard gauges perfectly, must be free from defects such as cracks, blisters, pits, welds, etc., and must be uniform in thickness throughout except at the weld where 2/100 of an inch additional thickness may be allowed. The present practice is to use tubes of from 2 to 21¼ inches in diameter. They vary in length from about 15 to 20 feet, the length depending on the construction of the boiler and locomotive as a whole. The tubes are supported at each end by letting them extend through the tube sheets. It is in the setting of the tubes that great care should be exercised. The tube sheets must be carefully aligned and the hole drilled through and reamed. These holes are usually made 1/16 of an inch larger in diameter than the outside diameter of the tubes. The tubes should be made not less than 1/4 nor more than 3/8 inch longer than the gauge distance over the front and back flue sheets. All back ends of tubes should be turned and beaded, and at least ten per cent of those in the front end. The number of tubes used varies according to the type and size of the locomotive but usually from 300 to 500 are employed. The flue sheets are made thicker than the other sheets of the boiler in order to give as wide a bearing surface for the tubes as possible. They are usually 5/8 inch thick. The flue sheets are braced or stayed by the flues and by diagonal braces fastened to the cylindrical shell. The bridges or metal in the flue sheets between two adjacent flues are usually made from 3/4 to 1 inch in width. The greater the width of the bridges, the greater the space between the flues; therefore, better circulation will be obtained.

**Stay-Bolts.** The universal method of staying flat surfaces of the fire-box at the sides and front is by the use of stay-bolts. These stay-bolts are screwed through the two sheets of the fire-box and are riveted over on both ends. [Fig. 40](#) illustrates a stay-bolt screwed into position and represents a strong and serviceable form. The stay-bolt is cut away between the sheets and only sufficient thread is cut at the ends to give it a hold in the metal. In [Fig. 40](#), *A* represents the inside sheet or the one next to the fire, and *B* represents the outside sheet. A small hole *C* is drilled into the outside end of the stay-bolt. This is known as the *tell-tale hole* and will permit the escape of water and steam should the bolt become broken.

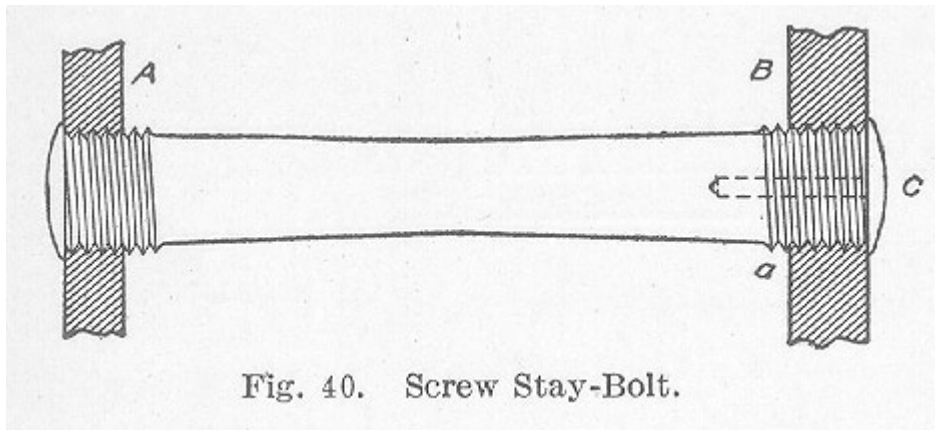
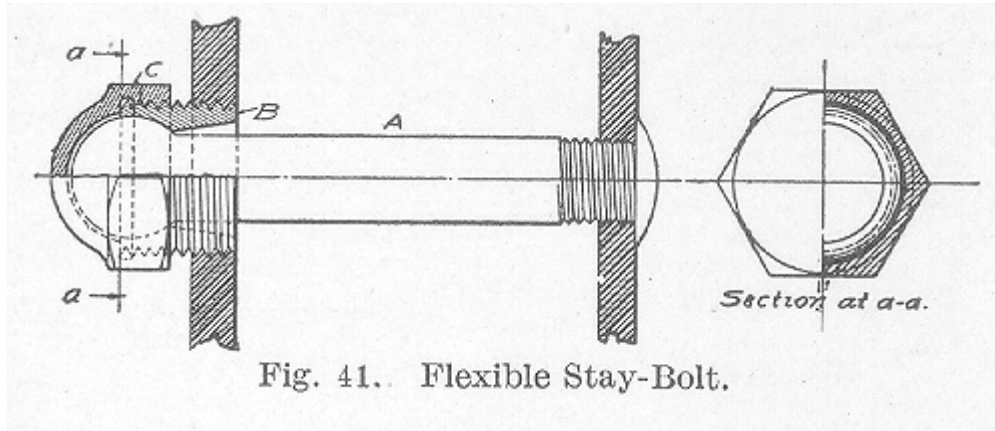

Fig. 40. Screw Stay-Bolt.

This tell-tale hole is usually 3/16 of an inch in diameter and 1 1/4 inches deep and is drilled at the outer end of the stay-bolt, since almost invariably the fracture occurs near the outer sheet. All boiler stay-bolts, including radial stays, have 12 Whitworth standard threads per inch. The most common cause of stay-bolts breaking is the bending at the point *B*, [Fig. 40](#), due to the expansion of the sheets *A* and *B*. The sheet *A*, being next to

the fire, is kept at a much higher temperature while the boiler is at work than the sheet *B*, which is subjected to the comparatively cool temperature of the atmosphere. This causes the plates *A* and *B* to have a movement relative to each other due to unequal expansion. The breakage is greatest at points where the greatest amount of movement takes place. As the two sheets are rigidly fastened to the mud ring, it is evident that the variation of expansion must start from that point; hence, the greatest vertical variation will be found at the top of the fire-box. In like manner, the back heads are securely fastened by stay-bolts so that horizontal variation must start at the back end; consequently the greatest horizontal variation will be found at the front end of the fire-box. The result of these two expansions will, therefore, be greatest at the upper portion of the front end. It is there that the greatest number of stay-bolt breakages occur.



In order to avoid these bending stresses, a number of different forms of flexible stay-bolts have been designed. One form of these is shown in [Fig. 41](#). The stay-bolt proper, *A*, has a ball formed on one end and a thread cut on the other. A plug *B* sets over the ball and forms a socket in which the latter can turn. As the stay-bolt is free to revolve in the plug, there is no necessity of the thread of the stay-bolt being cut in unison with the thread on the plug. Such a stay-bolt as this permits the inner sheet of the fire-box to move to and fro relative to the outer sheet without bending the outer end of the stay-bolt. Flexible stay-bolts when used are placed in what is known as the *zone of fracture*. [Fig. 42](#) and [Fig. 43](#) illustrate the application of flexible stay-bolts to a wide fire-box. [Fig. 42](#) shows five rows of flexible stay-bolts at each end of the fire-box and four rows at the bottom parallel to the mud ring. It should be remembered, however, that this is one installation only and that the arrangement in all cases may vary but this illustration is representative of good practice. Another illustration is shown in [Fig. 45](#). Here the flexible stay-bolts are shown by shaded circles. It is evident from [Fig. 43](#) that all the stays in the throat sheet are flexible, which is a very good arrangement since the stay-bolts in the throat sheet are subjected to very severe strains. On some railroads, flexible stay-bolts are put in the fire-box door sheets but this practice varies in some details for different roads.

Stay-bolts should be made of the best quality double refined iron free from steel, having a tensile strength of not less than 48,000 pounds per square inch. The bars must be straight, smooth, free from cinder pits, blisters, seams, or other imperfections. The common practice is to use stay-bolts 7/8 or 1 inch in diameter spaced about 4 inches from center to center.

Stay-bolt breakage is very large in bad water districts and gives a great deal of trouble on most railroads. The stay-bolt problem, therefore, is a very important one.

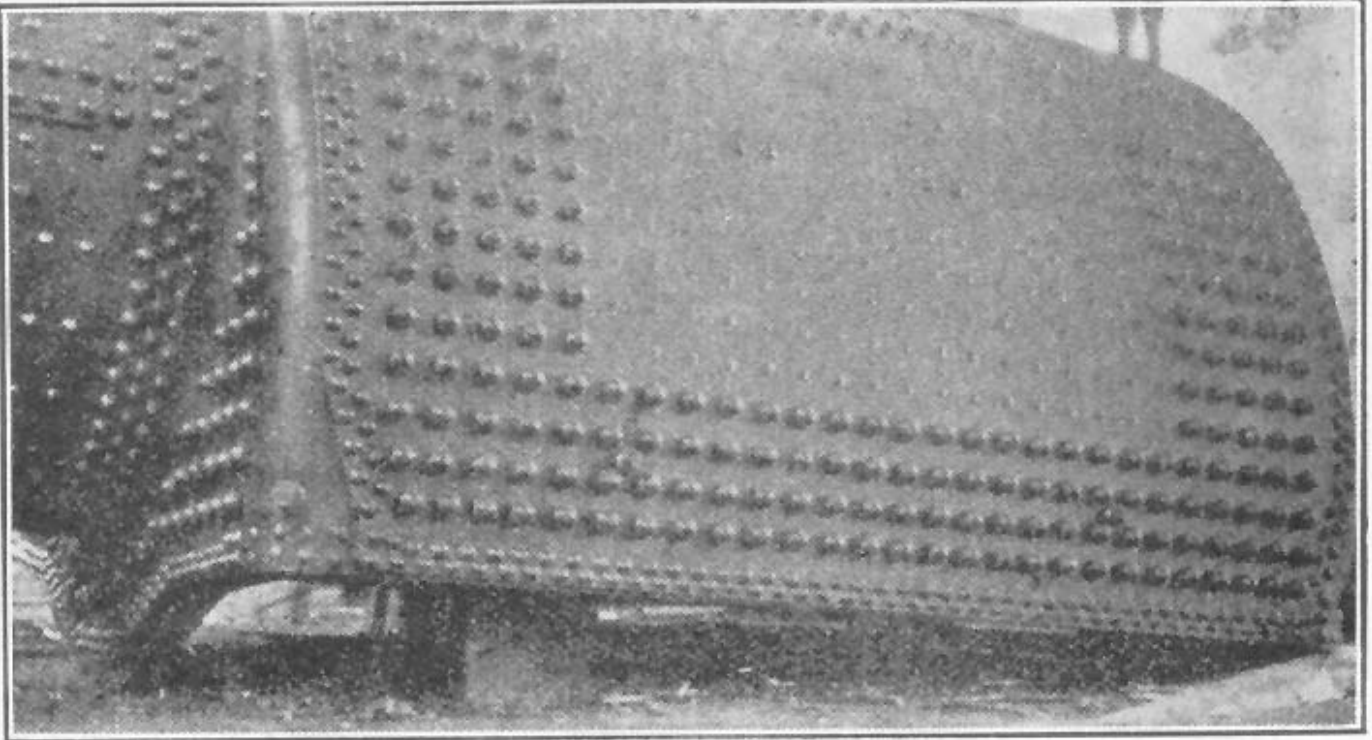

Fig. 42. Boiler, Showing Use of Flexible Stay-Bolts.

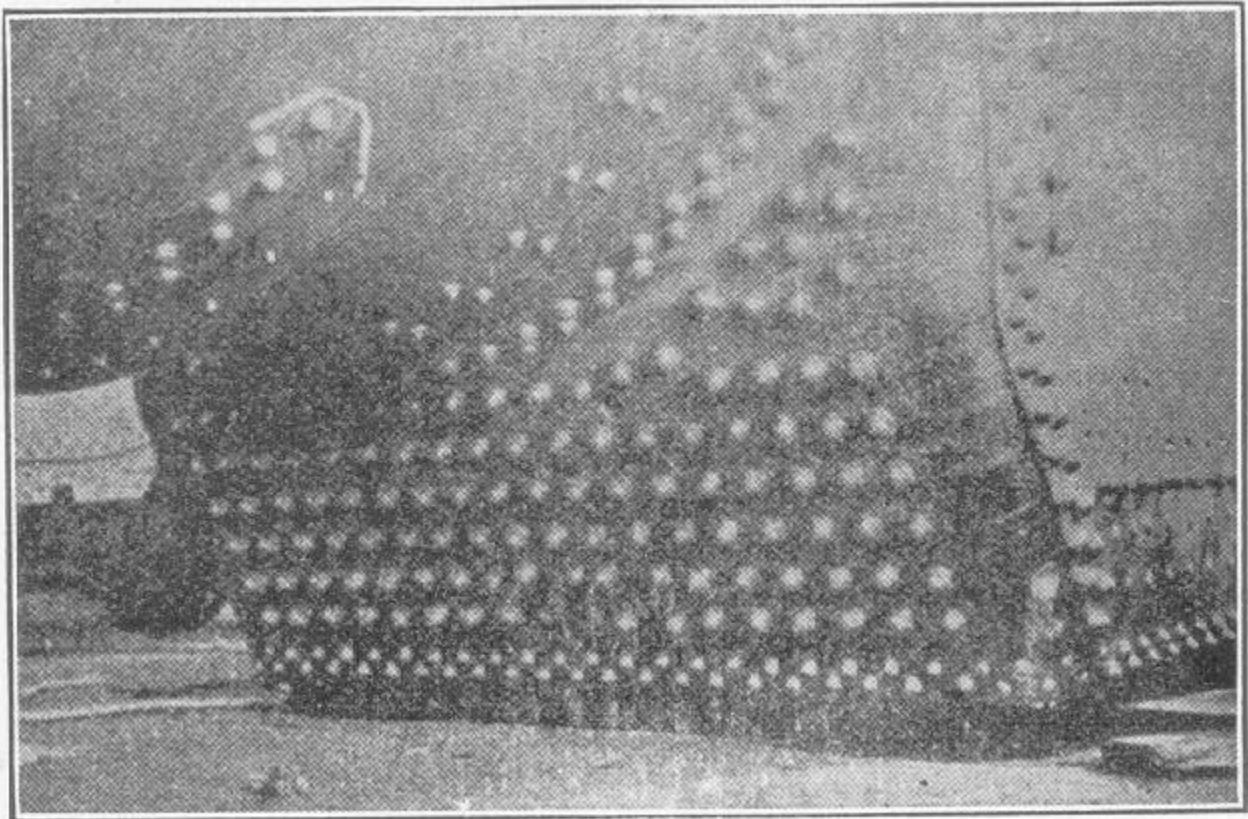

Fig. 43. Boiler, Showing Use of Flexible Stay-Bolts.



In addition to staying the sides and front and back ends, it is also necessary to stay the crown sheet. To accomplish this two general methods have been used. The oldest of these, by the use of crown bars, has almost passed out of service and well it is because of the many objectionable features it possessed. In this method, a number of crown bars were used which were supported by the edges of the side sheets and which were held

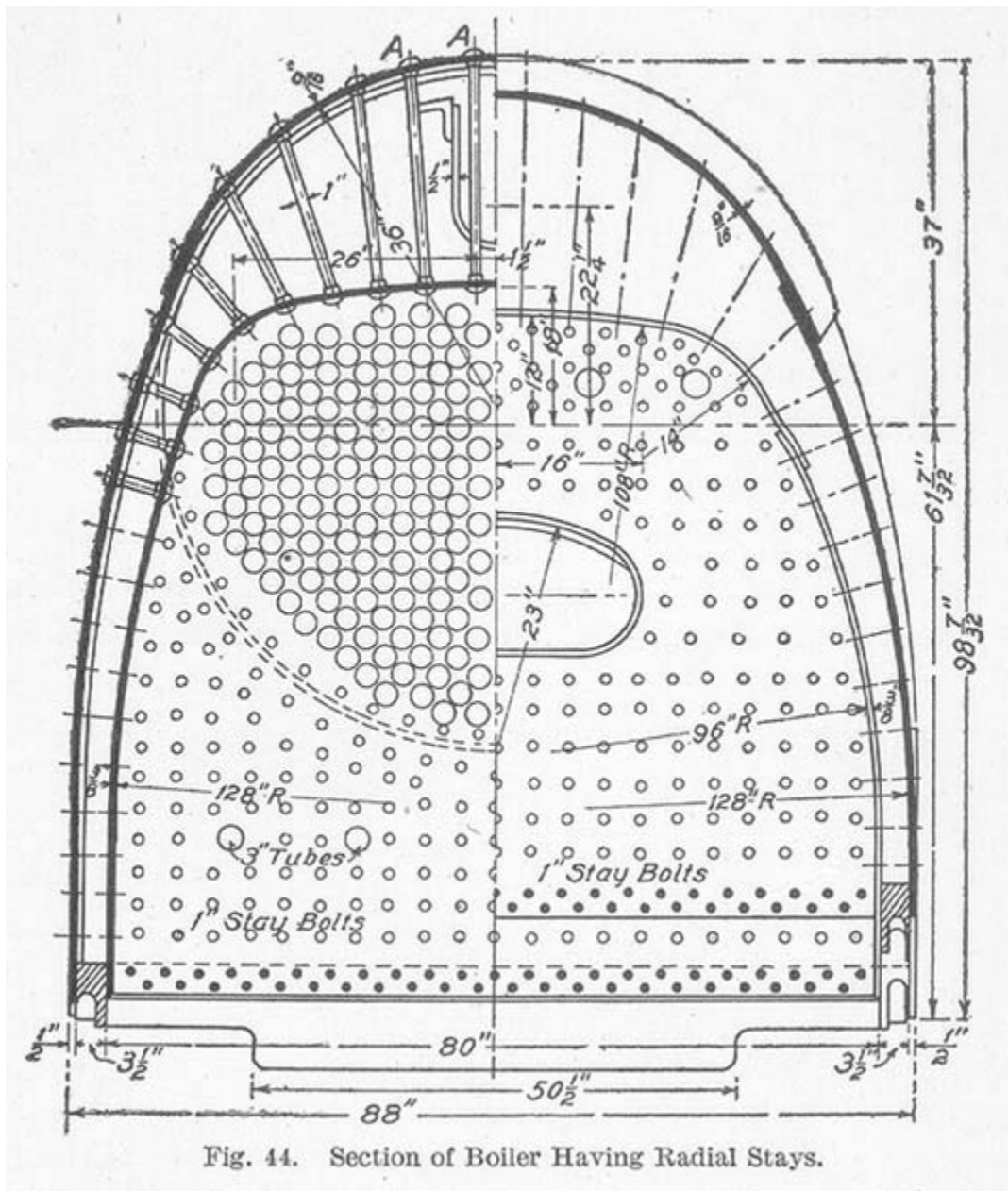

Fig. 44. Section of Boiler Having Radial Stays.

apart by spacers resting upon the crown sheet and to which the crown bars were tied by bolts. The crown sheet was supported by stay-bolts which were bolted to the crown bars. A great deal of the space over the crown sheet was taken up by these crown bars which greatly interfered with the circulation and made it very difficult in cleaning. The second method of staying the crown sheet is by means of radial stays. All stay-bolts over 8 inches in length are usually classified as radial stays. Radial stay-bolts are of the same general type and material as the stay-bolts already described, and are put in on radial lines; hence their name. [Fig. 44](#) shows a section of a boiler having radial stays *A*. These stays extend around the curved surface of the fire-box from the back to within two or

three rows of the front end as illustrated at *A*, [Fig. 45](#). The stays *B* in [Fig. 45](#) are of a different form and are frequently used in the front end to allow for expansion and contraction of the flue sheet. These extend around to the curved surface in the same manner as do the radial stays shown in [Fig. 44](#).

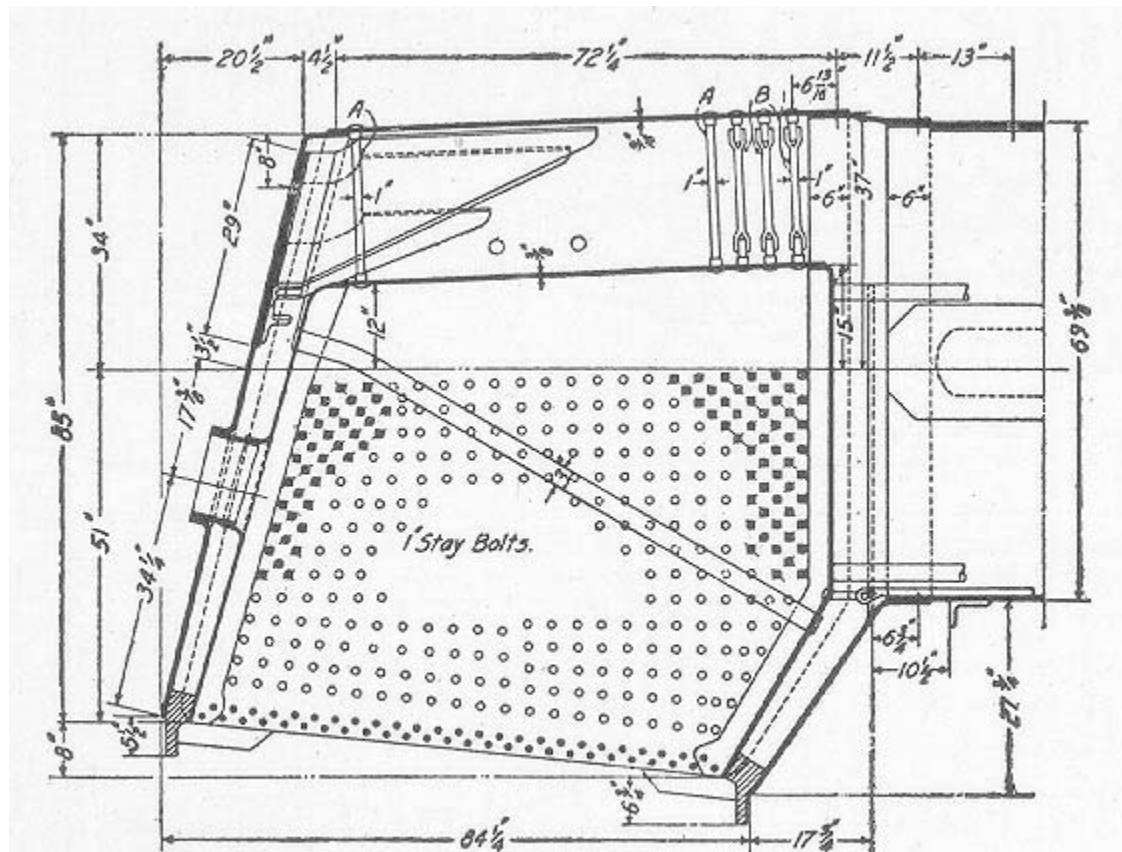

Fig. 45. Section Showing Two Types of Stays.

All radial stays should have enlarged ends with bodies  $\frac{3}{16}$  inch smaller in diameter than the outside diameter of thread. They should be made with button heads and should have threads under heads increased in diameter by giving the end a taper  $\frac{1}{2}$  inch in 12 inches. Radial stays commonly used are 1 inch,  $1 \frac{1}{8}$  inch, and  $1 \frac{1}{4}$  inch in diameter at the ends. The allowable safe fiber stress is 4,500 pounds per square inch.

**Grates.** The grate is made up of a set of parallel bars at the bottom of the fire-box, which hold the fuel. These bars are commonly made of cast iron and constructed in sections of three or four bars each. They are supported at their ends by resting upon a frame and are connected by rods to a lever which can be moved back and forth to rack the bars and shake ashes and cinders out of the fire. A drawing of such a grate is illustrated in [Fig. 46](#). When the grates occupy the full length of the fire-box they are divided into three sections, any one of which can be moved by itself. In the burning of anthracite coal, *water grates* are commonly used, a type of which is illustrated in [Fig. 47](#) and [Fig. 48](#). In [Fig. 47](#), the grate is formed of a tube *a* expanded into the back sheets of the fire-box and inclined downward to the front in order to insure a circulation of water. Opposite the back opening, a plug is screwed into the outer sheet which affords a means whereby the tube may be cleaned and a new one inserted in position if a repair is needed. At the front end,

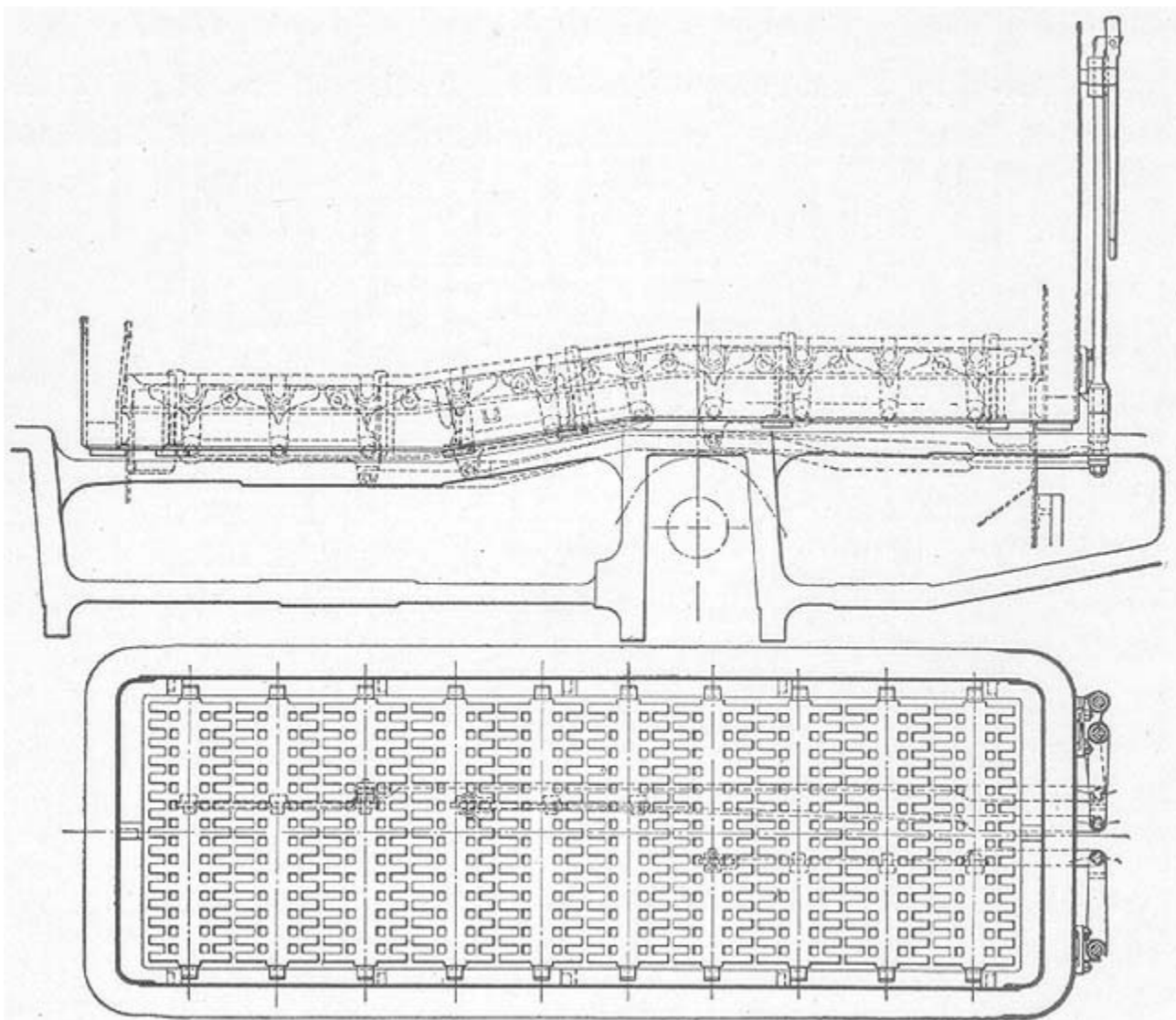

Fig. 46. Elevation and Plan of Grate.

the tube is usually screwed into the flue sheet. Water grates are rarely used alone but usually have spaced between them plain bars. These bars pass through tubes expanded into the sheets of the back water leg and by turning them, the fire may be shaken; and by withdrawing them, it may be dumped. [Fig. 48](#) shows a cross-section of the arrangement usually employed. In this figure, *A* represents the water tube and *B*, the grate bars.

**Ash Pans.** Ash pans are suspended beneath the fire-box for the purpose of catching and carrying the ashes and coal that may drop between the grate bars. They are made of sheet steel. [Fig. 49](#) illustrates a longitudinal section of an ash pan commonly used in fire-boxes placed between the axles of the engine. It is provided at each end with a damper *a* hinged at the top and which may be opened and set in any desired position in order to regulate the flow of air to the fire. It is quite important that the dampers should be in good condition in order that the admission of air to the fire may be regulated. The total unobstructed air openings in the ash pan need not exceed the total tube area but should not be less than 75 per cent. For many years the type shown in [Fig. 49](#) was almost universally used. More recently, however, a damper capable of better adjustment and more easily kept in condition has been developed. Such a damper is illustrated in [Fig. 50](#).



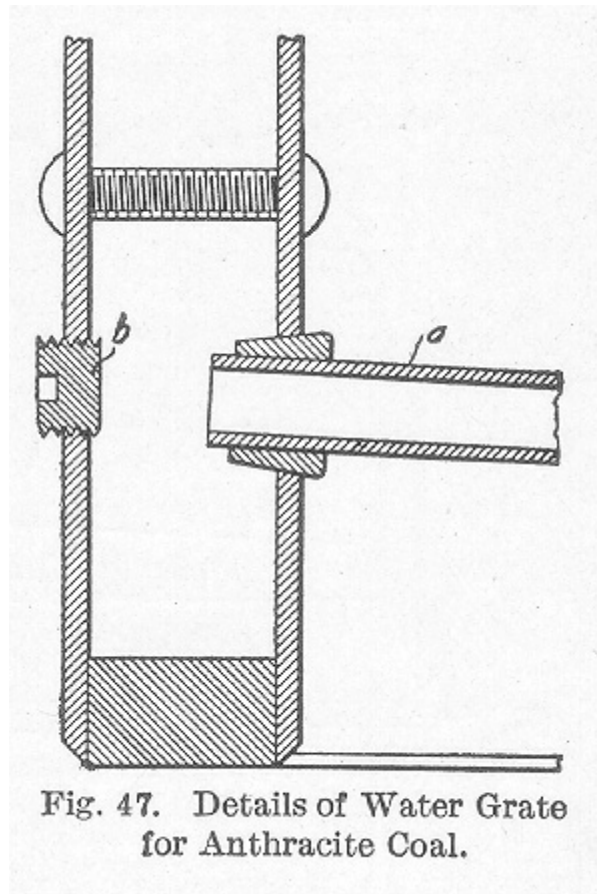

Fig. 47. Details of Water Grate for Anthracite Coal.

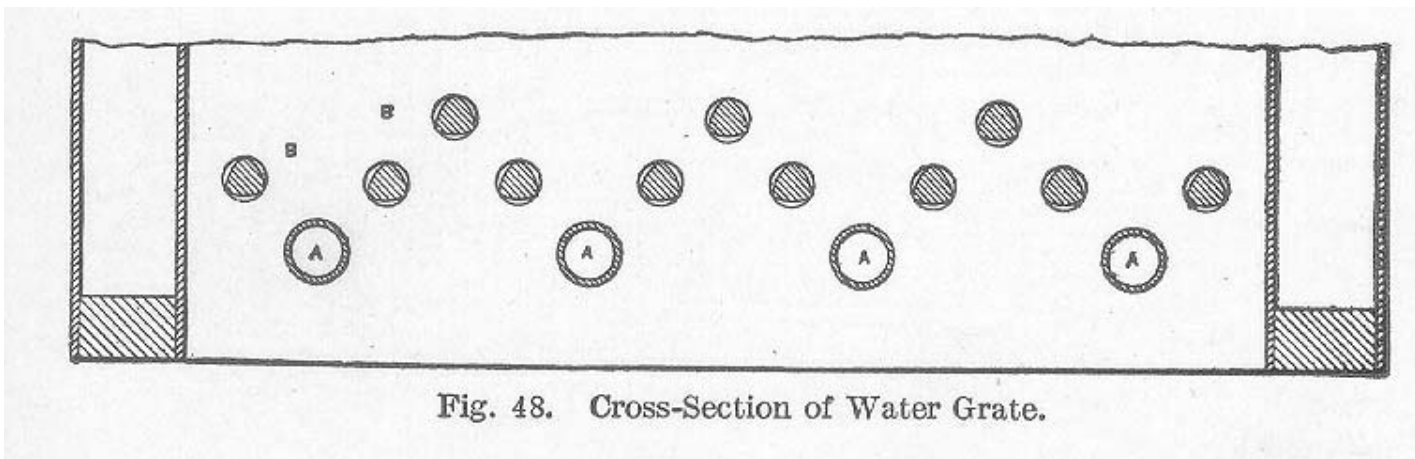

Fig. 48. Cross-Section of Water Grate.

In this type the dampers are placed upon the front faces of the ash pan and are raised and lowered by the contraction of levers and bell cranks. For example, the lifting of the bar *a* turns the bell crank *d* which pulls the connection *c c* which operates the forward bell crank and opens the front damper. In a similar manner, the rear damper *i* may be operated. If these dampers were made of cast iron and work in guides, it is possible to have the construction such that when closed they will be practically air tight.

**Brick Arches.** A brick arch is an arrangement placed in the fire-box to effect a better combustion and to secure a more even distribution of the hot gases in their passage through the tubes. [Fig. 33](#) illustrates a longitudinal section of the fire-box fitted with a brick arch *A*. Its method of action is very simple. It acts as a mixer of the products of combustion with the air and as a reflector of the radiant heat of the fire and the escaping

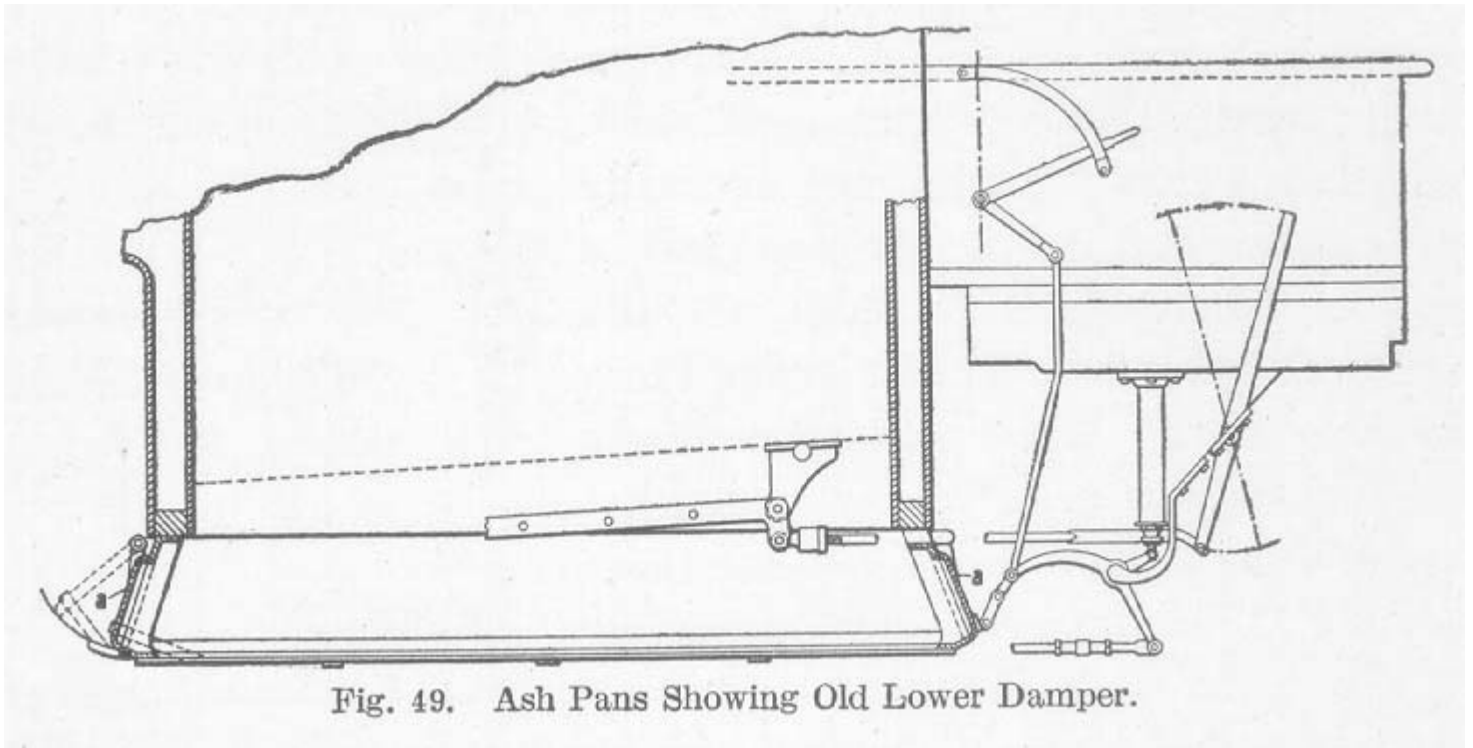

Fig. 49. Ash Pans Showing Old Lower Damper.

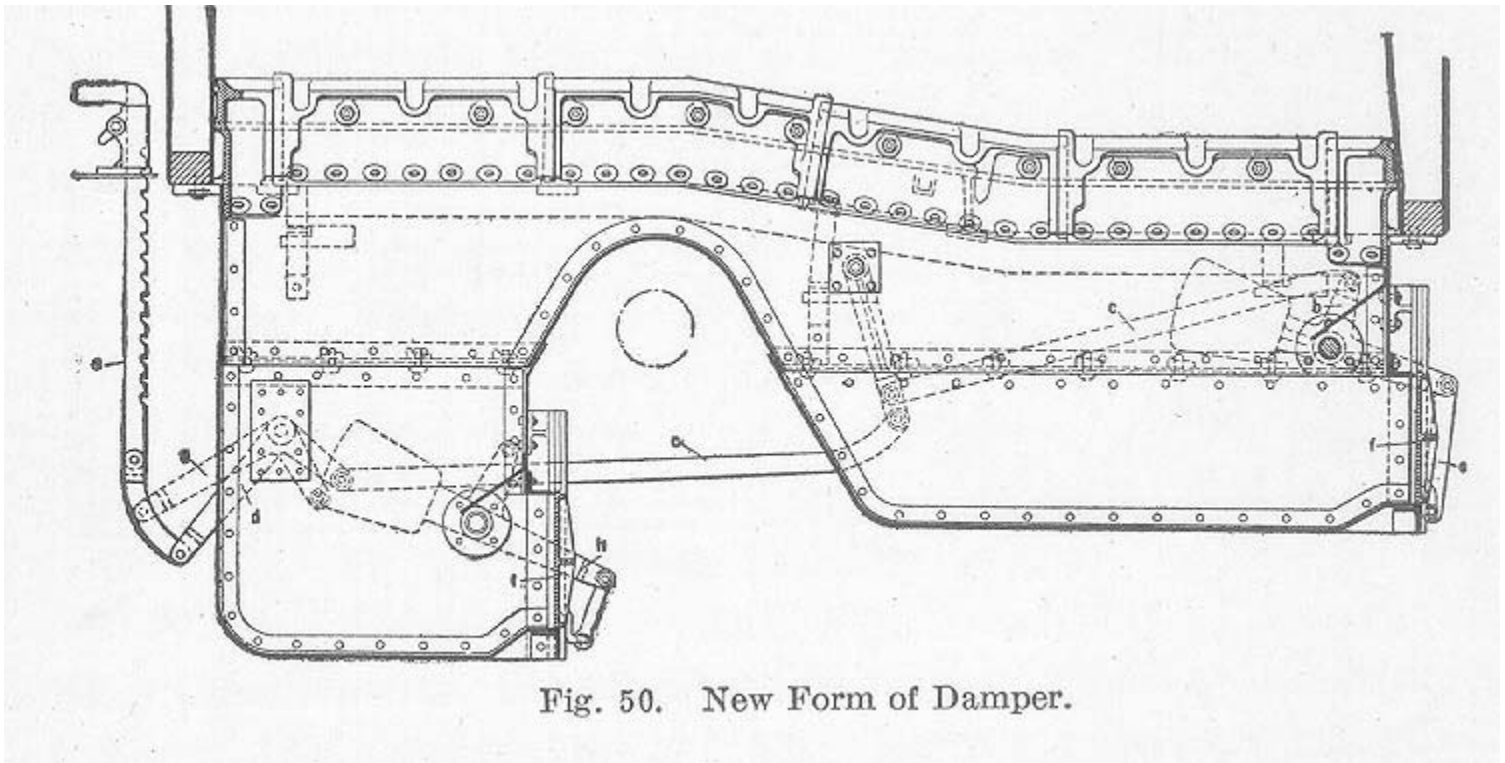

Fig. 50. New Form of Damper.

gases. It is maintained at a very high temperature and in this condition meets the air and gases as they come in contact with it and turns them back to the narrow opening above. By this action it maintains a temperature sufficiently high to burn with the smallest possible quantity of air all the carbonic oxide and the hydrocarbons that arise from the coal. It thus effects a very considerable saving in the cost of running, does away to a great extent with the production of smoke, and develops a high calorific power in comparatively small fire-boxes. This is a valuable property since it is possible for the

boiler to utilize the heat value of the coal to the greatest possible extent. The bricks are usually about 4 or 5 inches thick and are ordinarily supported either by water tubes, as shown in [Fig. 33](#) and [Fig. 45](#), or by brackets in the form of angleirons riveted to the side sheets. The disadvantage accruing from the use of the brick arch is that it is somewhat expensive to maintain because of the rapid deterioration and burning away of the material.

**Smoke-Box and Front End Arrangement.** By the term *front end* is meant all that portion of the boiler beyond the front tube sheet and includes the cylindrical shell of the boiler and all the parts contained therein such as the steam or branch pipes, exhaust nozzle, netting, diaphragm, and draft or petticoat pipes. These parts referred to above are illustrated in the sectional view shown in [Fig. 32](#).

**The Steam or Branch Pipes.** These pipes, 33, follow closely the contour of the shell and connect the T-head, 34, with the steam passage leading to the cylinder and conduct the steam from the dry-pipe to both the right and the left cylinders.

**Exhaust Nozzle.** The exhaust nozzle is the passage through which the steam escapes from the cylinders to the stack.

**Netting.** The netting, 26, is a coarse wire gauze placed in the front end which prevents large cinders from being thrown out by the action of the exhaust and thereby reduces the chances for fires being started along the right of way.

**Diaphragm.** The diaphragm or deflector plate, 27, is an iron plate placed obliquely over a portion of the front end of the flues which deflects the flue gases downward before entering the stack, thus equalizing to a great extent the draft in the different flues. This deflector plate may be adjusted to deflect the gases more or less as desired.

**Draft Pipes.** The petticoat or draft pipes, 36, employed to increase the draft may be used singly or in multiple and raised or lowered as desired.

**Draft.** The front end must be regarded as an apparatus for doing work. It receives power for doing this work from the exhaust steam from the cylinders. The work which it performs consists in drawing air through the ash pan, grates, fire, fire door, and other openings, then continues its work by drawing the gases of combustion through the flues of the boiler into the front end, then forcing them out through the stack into the atmosphere. In order that this work may be accomplished, a pressure less than the atmosphere must be maintained in the smoke-box. This is accomplished through the action of the exhaust jet in the stack. The difference in pressure between the atmosphere and the smoke-box is called *draft*.

Under the conditions of common practice, the exhaust jet does not fill the stack at or near the bottom but touches the stack only when it is very near the top. The action of the exhaust jet is to entrain the gases of the smoke-box. A jet of steam flowing steadily from the exhaust tip when the engine is at rest produces a draft that is in every way similar to that obtained with the engine running. The jet acts to induce motion in the particles of gas which immediately surround it and also to enfold and to entrain the gases which are thus made to mingle with the substance of the jet itself.

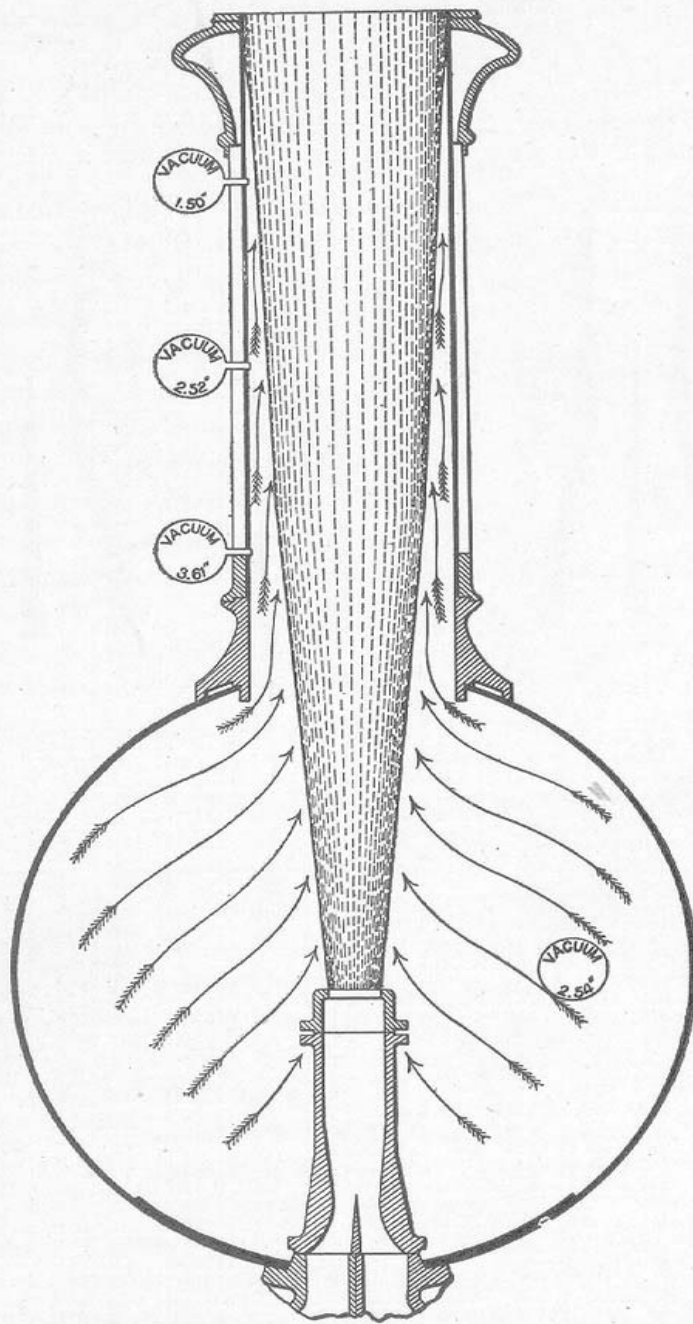

Fig. 51. Section of Exhaust Outlet into Stack, Showing Best Form to Produce Greatest Draft.

The induced action, illustrated in [Fig. 51](#), is by far the most important. The arrows in this figure represent the direction of the currents surrounding the jet. It will be seen that the smoke-box gases tend to move toward the jet and not toward the base of the stack; that is, the jet by the virtue of its high velocity and by its contact with certain surrounding gases gives motion to the particles close about it and these moving on with the jet make room for other particles farther away. As the enveloping stream of gas approaches the top of the stack its velocity increases and it becomes thinner. The vacuum in the stack decreases towards the top. Thus the jet in the upper portion of the stack introduces a vacuum in the lower portion just as the jet as a whole induces a vacuum in the smoke-box. It will be found that the highest vacuum is near the base of the stack. It is higher than the smoke-box on account of the large volume of gas in the latter and it grows less toward the top of the stack. This is illustrated by the different gauges

shown in [Fig. 51](#).

**Exhaust Nozzles.** It has been determined by experiment that the most efficient form of exhaust nozzle is that which keeps the jet in the densest and most compact form. Tests indicate that the nozzle giving the jet the least spread is the most efficient. Of the three forms of exhaust nozzles shown in [Fig. 52](#), the spread of the jet is least for *a* and most for



c. Nozzle *a* ends in a plain cylindrical portion 2 inches in length. Nozzle *c* is contracted in the form of a plain cylinder ending in an abrupt cylindrical contraction. It has been common practice, in cases where engines refuse to steam properly, to put across the

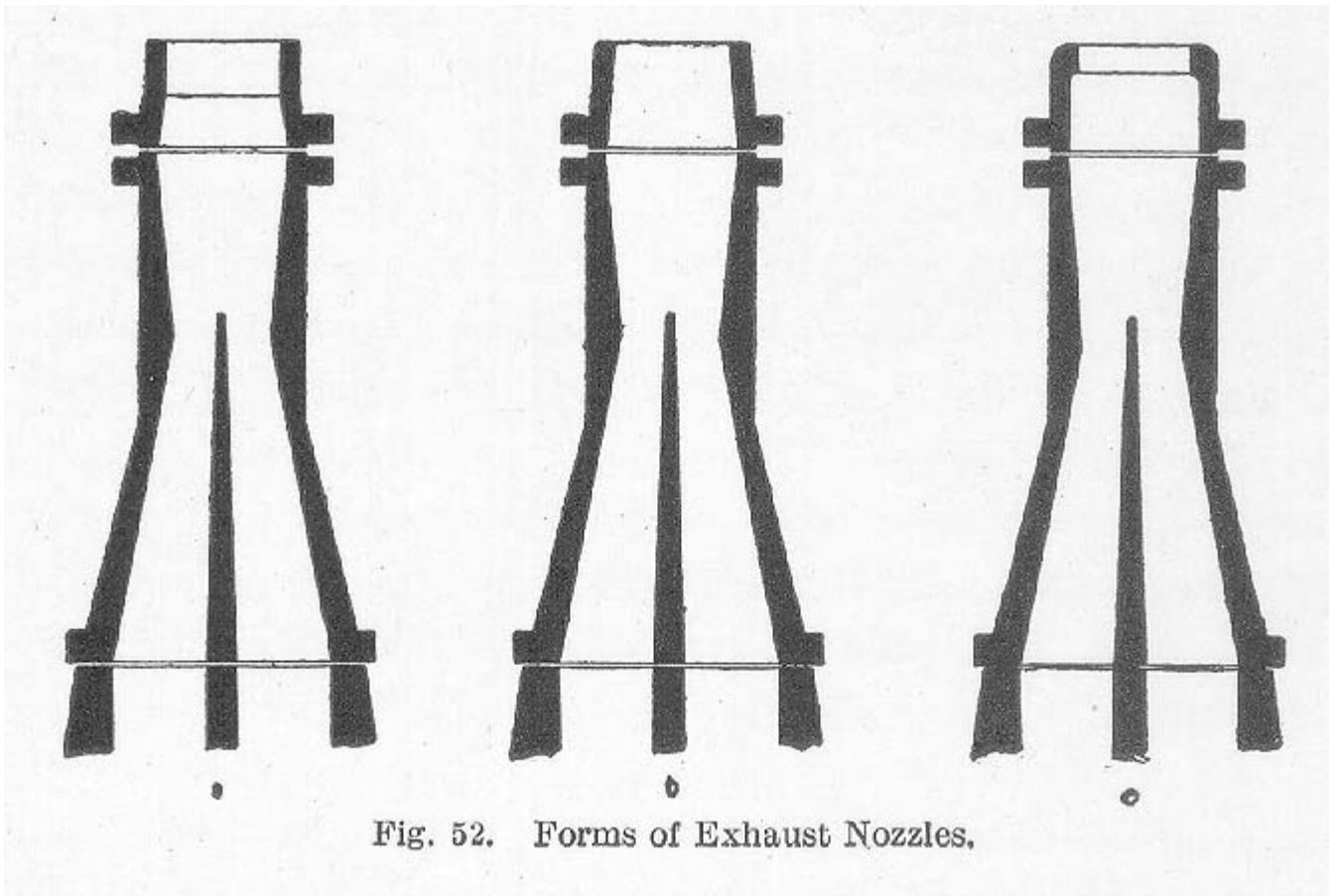

Fig. 52. Forms of Exhaust Nozzles.

exhaust nozzles round or knife-shaped bridges as indicated in [Fig. 53](#). The use of bridges accomplishes the desired result but experiments have shown that this method materially affects the efficiency of the engine because of the increase of back pressure in the cylinders. It is, therefore, best not to split up the jet by using a bridge in cases where the draft is unsatisfactory, as the desired results may be obtained by reducing the diameter of the exhaust nozzle.

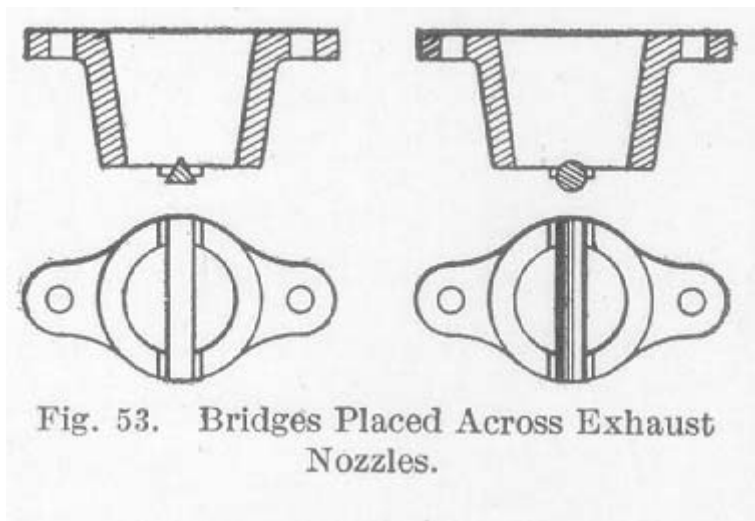
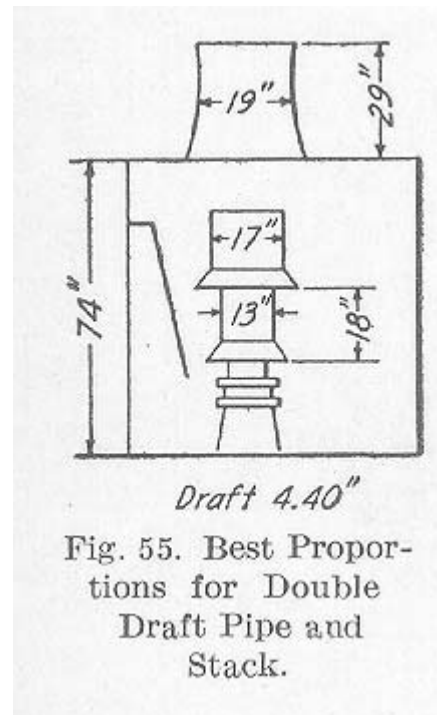
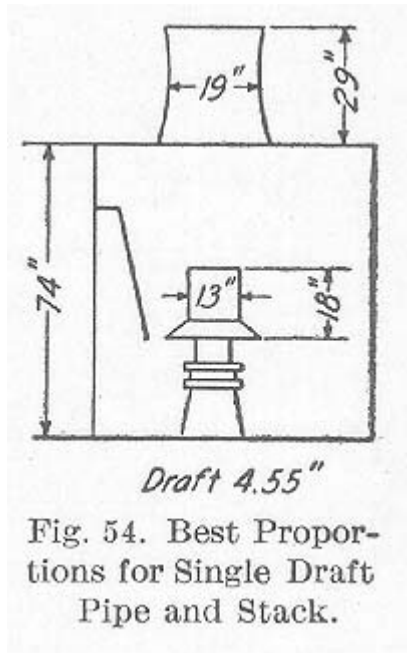

Fig. 53. Bridges Placed Across Exhaust Nozzles.

As previously stated, draft or petticoat pipes are used for the purpose of increasing the draft or vacuum in the front end and in the tubes. A great many tests have been made under the supervision of the Master Mechanics' Association to determine the proper proportions of the petticoat pipes and their best relative position with reference to the stack and exhaust nozzle.

The report of the committee of the Master Mechanics' Association with reference to single draft pipes states "that for the best results, the presence of a draft pipe requires a smaller stack than would be used without it but that no best combination of single draft pipe and stack could be found which gave a better draft than could be obtained by the use of a properly proportioned stack without the draft pipe. While the presence of a draft pipe will improve the draft when the stack is small it will not do so when the stack is sufficiently large to serve without it. The best proportion and adjustment of a single draft pipe and stack are shown in [Fig. 54.](#)"



The finding of the same committee with reference to the use of the double draft pipes is as follows: "Double draft pipes of various diameters and lengths and having many different positions within the front ends all in combination with stacks of different diameters, were included in the experiments with results which justify a conclusion similar to that reached with reference to single draft pipes. Double draft pipes make a small stack workable. They cannot serve to give a draft equal to that which may be obtained without them provided the plain stack is suitably proportioned. The arrangements and proportions giving the best results are illustrated in [Fig. 55.](#)"

**Stack.** The stack is one of the most important features of the front end. Many different forms and proportions of stacks have been employed but at the present time only two

general types are found in use to any great extent, namely, the *straight* and *tapered stacks*.

In connection with tests conducted in the Locomotive Testing Laboratory at Purdue University, it has been found that the tapered stack gives much better draft values than the straight stack. It was also found that the effect on the draft due to minor changes of proportion, both of the stack itself and the surrounding mechanism, was least noticeable when the tapered stack was used than was the case with the straight stack. A variation of one or two inches in the diameter of the tapered stack or height of the exhaust nozzle affected the draft less than similar changes with a straight stack. For these reasons, the

tapered stack was recommended in preference to the straight stack. By the term *tapered stack* as herein referred to, is meant a stack having its least diameter or choke 16½ inches from the bottom, and a diameter above this point increasing at the rate of two inches for each additional foot.

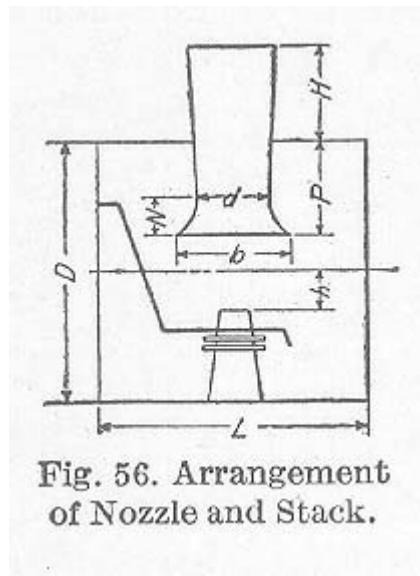

Fig. 56. Arrangement of Nozzle and Stack.

The diameter of any stack designed for best results is affected by the height of the exhaust nozzle. As the nozzle is raised, the diameter of the stack must be reduced and as the nozzle is lowered, the diameter of the stack must be increased. From the facts mentioned above, it can be seen there exists a close relation between the exhaust nozzle, petticoat pipe, stack, and the diaphragm; hence a standard front end arrangement has been recommended and is presented herewith.

The best arrangement of front end apparatus is shown in [Fig. 56](#), in which

- $H$  = height of stack above boiler shell in inches
- $D$  = diameter of shell in inches
- $L$  = length of the front end in inches
- $P$  = the distance in inches stack extends into the smoke-box
- $N$  = distance in inches from base of stack to choke
- $b$  = width of stack in inches at the base
- $d$  = diameter of stack in inches at the choke
- $h$  = distance in inches of the nozzle below the center line of smoke-box

In order to obtain the best results,  $H$  and  $h$  should be made as great as possible while the other principal dimensions should be as follows:

$$d = .21 D + .16 h$$

$$b = 2 d \text{ or } .5 D$$

$$P = .32 D$$

$$N = .22 D$$

**Rate of Combustion.** It is a well-known fact that each pound of fuel is capable of giving out a certain definite amount of heat. Therefore, the more rapid the combustion, the greater the amount of heat produced in a given time. In stationary boilers, where the grate is practically unlimited, the rate of combustion per square foot of grate area per hour

varies from 15 to 25 pounds. In locomotives, however, where the grate area is limited, the fuel consumption is much greater, rising at times as high as 200 pounds per square foot of grate area per hour. This rapid combustion results in a great loss of heat and a reduction in the amount of water evaporated per pound of coal. It has been shown that when coal is burned at the rate of 50 pounds per square foot of grate area per hour, 8¼ pounds of water maybe evaporated for each pound of coal. While if the rate of combustion is increased to 180 pounds per square foot of grate area per hour, the evaporation will fall off to about five pounds, a loss of water evaporated per pound of coal of nearly 40 per cent. This loss may be due to a failure of the heating surface to absorb properly the increased volume of heat passing over them, or to the imperfect combustion of the fuel on the grate, or it may be due to a combination of these causes.

The results of experiments show that the lower the rate of combustion the higher will be the efficiency of the furnace, the conclusion being that very high rates of combustion are not desirable and consequently that the grate of a locomotive should be made as large as possible so that exceptionally high rates of combustion will not be necessary.

With high rates of combustion, the loss by sparks is very serious and may equal in value all of the losses occurring at the grate. [Fig. 57](#) is a diagram representing the losses that

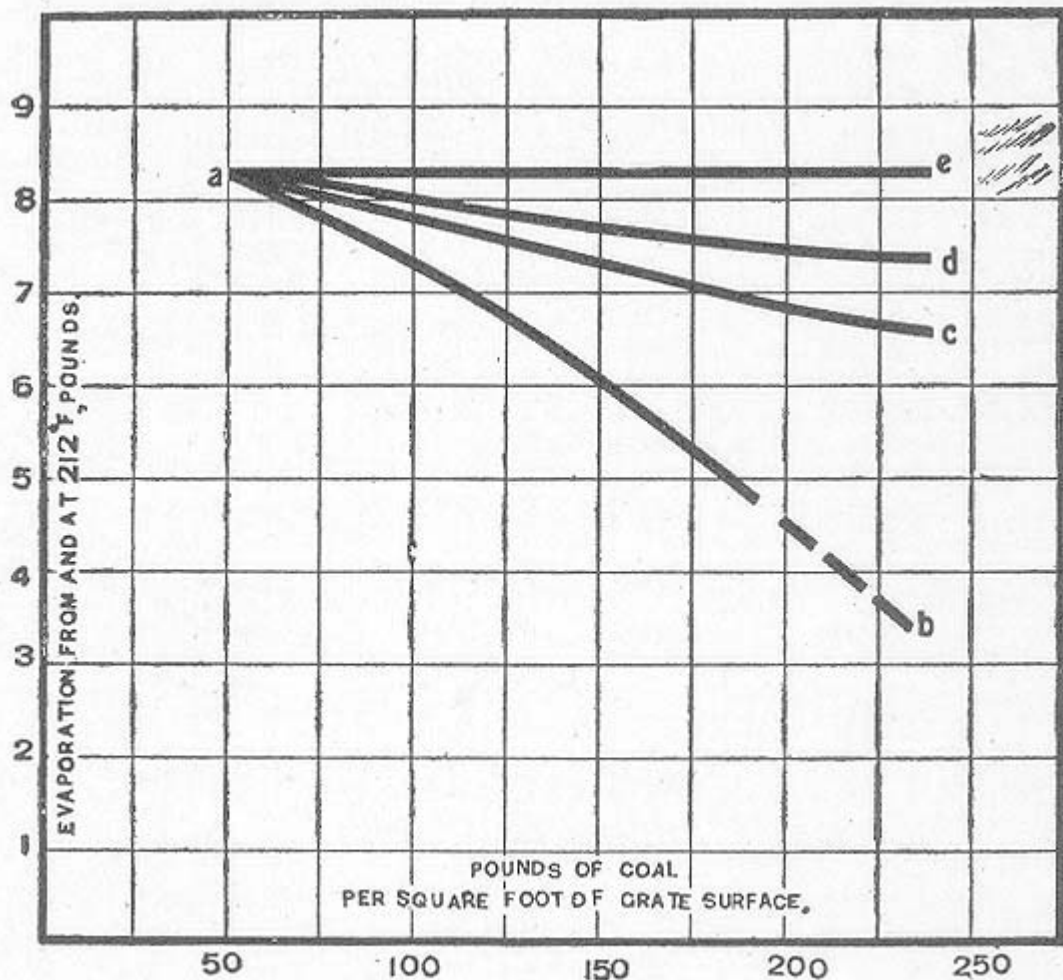

Fig. 57. Curves Showing Losses Due to Increases in Rate of Combustion.



occur, due to an increase in the rate of combustion. The line *a b* illustrates graphically the amount of water evaporated per pound of coal for the various rates of combustion. Thus, with a rate of 50 pounds per square foot of grate area per hour,  $8\frac{1}{4}$  pounds of water are evaporated. When the rate of combustion is raised to 175 pounds, only about  $5\frac{1}{3}$  pounds of water are evaporated. It is thus seen that the efficiency of the locomotive from the standpoint of water evaporated per pound of coal decreases as the rate of combustion per square foot of grate area increases. If it could be assumed that the heat developed in the furnace would be absorbed with the same degree of completeness for all rates of combustion, the evaporation would rise to the line *a c*. If, in addition to this, it could be assumed that there were no spark losses, the evaporation would rise to the line *a d*. Finally, if in addition to these, it could be assumed that there were no losses by the excess admission of air or by incomplete combustion, then the evaporation would remain constant for all rates of combustion and would be represented by the line *a e*. That is, with the boiler under normal conditions, the area *a b c* represents the loss occasioned by deficient heating surface; the area *a c d* represents that caused by spark losses; and the area *a d e* represents that due to excessive amounts of air and by imperfect combustion.

**Spark Losses.** From the diagram shown in [Fig. 57](#), it is evident that one of the principal heat losses is that of sparks. By the term *sparks* is meant the small particles of partially burned coal which are drawn through the flues and ejected through the stack by the action of the exhaust. In the operation of a locomotive, it has been demonstrated that the weight of sparks or cinders increases with the rate of combustion and may reach a value of from 10 to 15 per cent of the total weight of coal fired. Damage suits frequently arise, due to fires started by cinders thrown from the stack of the locomotive. Experiments have shown, however, that sparks from a locomotive will not be likely to start fires beyond the right of way.

**High Steam Pressures.** With the development of high-power locomotives came the use of high steam pressures. At first, only very low pressures were carried but soon 200 pounds pressure per square inch became very common and 220 and 225 not unusual. But with the increase of pressure there came an increase in trouble due to bad water, leaky flues, and an increase in incidental leaks in the boiler. All of these factors affected the performance of the locomotive. To determine to what extent the economic performance of the boiler was affected by an increase of steam pressure and also the most economical steam pressure to use, a series of tests were carried out at Purdue University. The following are the conclusive results as read before the Western Railway Club by Dean W. F. M. Goss:

#### **THE EFFECT OF DIFFERENT PRESSURES UPON BOILER PERFORMANCE**

1. The evaporative efficiency of a locomotive boiler is but slightly affected by changes in pressure between the limits of 120 pounds and 240 pounds.
2. Changes in steam pressure between the limits of 120 pounds and 240 pounds will produce an effect upon the efficiency of the boiler which will be less than one-half pound of water per pound of coal.
3. It is safe to conclude that changes of no more than 40 or 50 pounds in pressure will produce no measurable effect upon the evaporative efficiency of the modern locomotive boiler.

## THE EFFECT OF DIFFERENT PRESSURES UPON SMOKE-BOX TEMPERATURES

1. The smoke-box temperature falls between the limits of 590 degrees F. and 860 degrees F., the lower limit agreeing with the rate of evaporation of 4 pounds per foot of heating surface per hour and the higher with a rate of evaporation of 14 pounds per square foot of heating surface per hour.
2. The smoke-box temperature is so slightly affected by changes in steam pressure as to make negligible the influence of such changes in pressure for all ordinary ranges.

### CONCLUSIONS

1. The steam consumption under normal conditions of running has been established as follows:

BOILER PRESSURE.....STEAM per HORSEPOWER HOUR

120.....29.1

140.....27.7

160.....26.6

180.....26.0

200.....25.5

220.....25.1

240.....24.7

2. The results show that the higher the pressure, the smaller the possible gain resulting from a given increment of pressure. An increase of pressure from 160 to 200 pounds results in a saving of 1.1 pounds of steam per horse-power per hour while a similar change from 200 pounds to 240 pounds improves the performance only to the extent of .8 of a pound per horse-power hour.
3. The coal consumption under normal conditions of running has been established as follows:

BOILER PRESSURE.....COAL per HORSEPOWER HOUR

120.....3.84

140.....3.67

160.....3.53

180.....3.46

200.....	3.40
220.....	3.35
240.....	3.31

4. An increase of pressure from 160 to 200 pounds results in a saving of 0.13 pounds of coal per horse-power hour while a similar change from 200 to 240 results in a saving of but 0.09 pounds.
5. Under service conditions, the improvement in performance with increase of pressure will depend upon the degree of perfection attending the maintenance of the locomotive. The values quoted in the preceding paragraphs assume a high order of maintenance. If this is lacking, it may easily happen that the saving which is anticipated through the adoption of higher pressures will entirely disappear.
6. The difficulties to be met in the maintenance both of boiler and cylinders increase with increase of pressure.
7. The results supply an accurate measure by which to determine the advantage of increasing the capacity of a boiler. For the development of a given power, any increase in boiler capacity brings its return in improved performance without adding to the cost of maintenance or opening any new avenues for incidental losses. As a means of improvement it is more certain than that which is offered by increase of pressure.
8. As the scale of pressure is ascended an opportunity to further increase the weight of a locomotive should in many cases find expression in the design of a boiler of increased capacity rather than in one of higher pressures.
9. Assuming 180 pounds pressure to have been accepted as standard and assuming the maintenance to be of the highest order, it will be found good practice to utilize any allowable increase in weight by providing a larger boiler rather than by providing a stronger boiler to permit higher pressures.
10. Whenever the maintenance is not of the highest order, the standard running pressures should be below 180 pounds.
11. Where the water which must be used in boilers contains foaming or scale-making admixtures, best results are likely to be secured by fixing the pressure below the limit of 180 pounds.
12. A simple locomotive using saturated steam will render good and efficient service when the running pressure is as low as 160 pounds. Under most favorable conditions, no argument is to be found in the economical performance of a machine which can justify the use of pressures greater than 200 pounds.

**Heating Surface.** While the points thus far considered are more or less important in their bearing in the generation of steam, yet the amount of heating surface is, as a rule, the most important. As previously stated, the lower the rate of combustion per square foot of heating surface, the higher will be the rate of evaporation per pound of coal. The ratio of the heating surface of the flues to that of the fire-box varies greatly, in some cases being only 9 to 1 while in others it is found as great as 18 to 1. There is perhaps a correct value for this ratio, but at the present time it is unknown. The relation existing between the total heating surface and the grate area varies between wide limits for different cases. Table III, taken from the Proceedings of the Master Mechanics' Association for 1902, gives the



ratio of heating surface to grate area in passenger and freight locomotives burning various kinds of fuel.

**TABLE III**

**Ratio of Heating Surface to Grate Area**

<b>Fuel</b>	<b>Passenger Locomotive Simple</b>	<b>Passenger Locomotive Compound</b>	<b>Freight Locomotive Simple</b>	<b>Freight Locomotive Compound</b>
Free Burning Bituminous	65 to 90	75 to 95	70 to 85	65 to 85
Average Bituminous	50 to 65	60 to 75	45 to 70	50 to 65
Slow Burning Bituminous	40 to 50	35 to 60	35 to 45	45 to 50
Bituminous, Slack, and Free Burning Anthracite	35 to 40	30 to 35	30 to 35	40 to 45
Low Grade Bituminous, Lignite, and Slack	28 to 35	24 to 30	25 to 30	30 to 40

From the foregoing, it is evident that it is exceedingly difficult to determine just how much heating surface a locomotive boiler should have to give the best results. As a rule, they are made as large as possible so long as the total allowable weight of the locomotive is not exceeded. This is not, however, a scientific rule to follow but it is safe to say that the value of no locomotive has ever been impaired by having too much heating surface. The greater the boiler power, the higher will be the speed which can be maintained. It is important that the boiler be covered with a good lagging in order to prevent loss of heat due to radiation.

**Superheaters.** When steam is admitted to the cylinder it meets the cylinder walls, the temperature of which is less than that of the entering steam, and there results an interchange of heat. The fact that the steam gives up a part of its heat to the cylinder, causes some of the steam to condense. As the piston proceeds on its stroke and expansion occurs, some of the steam initially condensed will be re-evaporated. The cylinder, therefore, goes through a process of alternately cooling and reheating, resulting in condensation and re-evaporation; this is the principal loss occurring in the process.

In order to assist in reducing this loss to a minimum, superheated steam is being used on locomotives, to a certain limited extent in the United States, by the addition of a superheater. A superheater consists of a series of tubes and headers usually placed in the smoke-box, through which steam passes on its way to the cylinders, thus raising its temperature. It has now secured a certain amount of heat energy from the waste gases which pass out of the stack, thus improving the economy of the locomotive.

*Pielock Superheater.* The Pielock superheater, illustrations of which are shown in [Fig. 58](#) and [Fig. 59](#), is found in use on a number of railways in Germany and in Italy, and also on the Hungarian State Railways. Its construction consists of a box containing tube plates corresponding to those of the boiler, the box being set in the boiler barrel so that the flues pass through it. It is placed at such a distance from the fire-box as will prevent the tubes

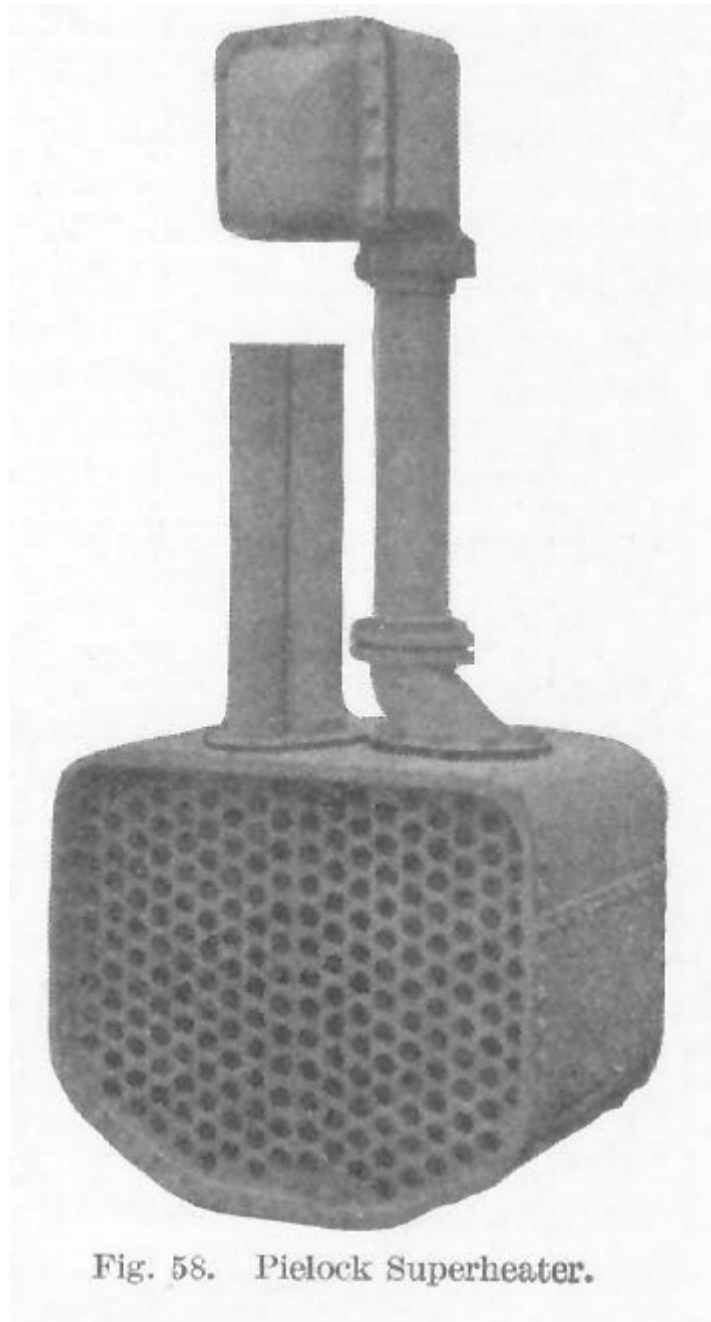

from becoming overheated. The vertical baffle plates *G* between the rows of tubes cause the steam to follow a circuitous path passing up and down between the tubes. The steam from the dome passes down the open pipe *A*, [Fig. 59](#), to the left-hand chamber *B*, then transversely to the several chambers as shown by arrows until it reaches the right-hand chamber *C*. From the chamber *C* it passes up through the pipe *D* to the chamber enclosing a throttle valve from which it enters the steam pipe *E*.

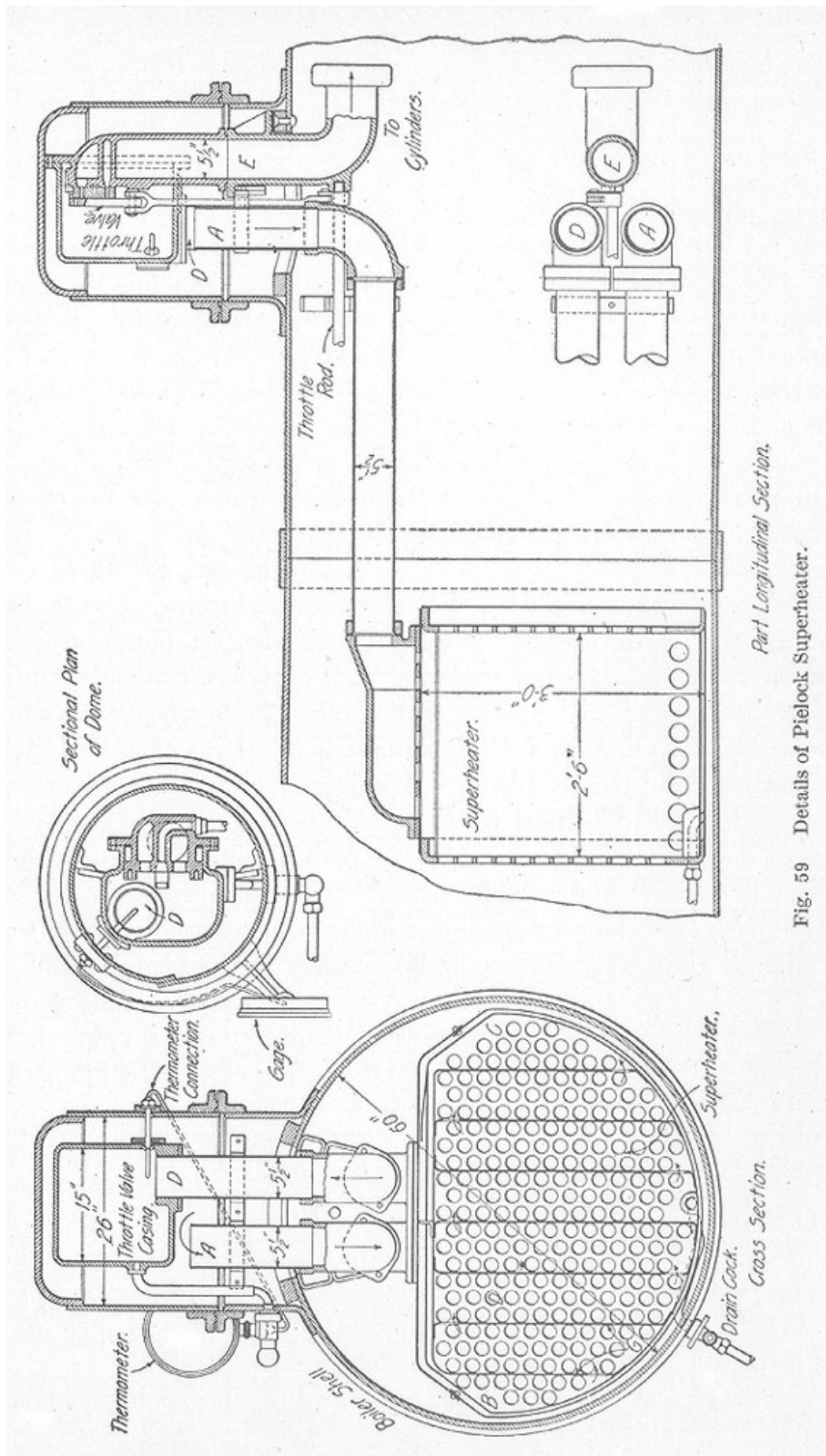

Fig. 59 Details of Piolock Superheater.

In installing the superheater, the boiler tubes are first set in place in the superheater and then placed in the boiler, the smoke-box tube plate being left off for this purpose. The tubes are first expanded into the fire-box or back flue-sheet, then in the superheater plates (for which a special mandrel is used), and finally in the front flue-sheet. A blow-off cock extends from the bottom of the superheater through the boiler by means of which any leaks in the superheater may be detected. A gauge at the bottom indicates the degree of superheat of the steam in the throttle valve chamber.

This type of superheater can be applied to a locomotive without making any alteration since the superheater is built to fit the boiler in which it is to be used. It does not interfere with the cleaning of the flues or the washing out of the boiler. It is reported that by the use of this superheater a saving in coal of about 15 to 18 per cent and in water of about 20 per cent, is effected.

*Schmidt Superheater.* The Schmidt superheater is another type which is largely used on German railroads. Its construction is based on entirely different principles from those of the Pielock superheater. It differs from the Schenectady or Cole superheater in details only.

*Schenectady or Cole Superheater.* The Schenectady superheater was developed by the American Locomotive Company. It has had a large application in recent years and good results are being obtained. The general arrangement and construction of this superheater is shown in [Fig. 60](#) and [Fig. 61](#).

The use of bent tubes and the necessity for dismantling the whole apparatus in order to repair a single leaky boiler tube gave rise to many objections to the use of superheaters. In the construction of the Schenectady superheater, many of the objectionable features have been eliminated. By reference to [Fig. 60](#), it will be seen that steam entering the T-pipe from the dry pipe *A* is admitted to the upper compartment only. To the front side of the T-pipe are attached a number of header castings *B*, the joint being made with copper wire gaskets, as in steam chest practice. Each header casting is subdivided into two compartments by a vertical partition shown in cross-section at *C*. Five tubes each 1 1/16 inch outside diameter are inserted through holes (subsequently closed by plugs) in the front wall of each header casting. These tubes having first been expanded, special plugs are firmly screwed into the vertical partition wall and are enclosed by five 1 3/4-inch tubes which are expanded into the rear wall of the header casting in the usual way. Each nest of two tubes is encased by a regular 3-inch boiler tube which is expanded into the front and back tube sheets as usual. The back end of each inner tube is left open and the back end of each middle tube is closed. The back ends of the two tubes are located about 36 inches forward from the rear flue sheet. The arrangement of the three flues is shown in [Fig. 61](#). The inner tube is allowed to drop and rest on the bottom of the middle tube while the end of the middle tube is so constructed as to support both the inner and middle tubes in the upper part of the 3-inch tube, thus leaving a clear space below.

As can be seen from [Fig. 60](#), steam from the dry pipe enters the forward compartments of each of the header castings, passes back through each of the inner tubes, thence forward through the annular space between the inner and middle tubes, through the rear compartments of each of the header castings, and thence into the lower compartment of the T-pipe, thence by the right and left steam pipe *D* and *E* to the cylinders. The steam in passing through the different channels is superheated by the smoke-box gases and

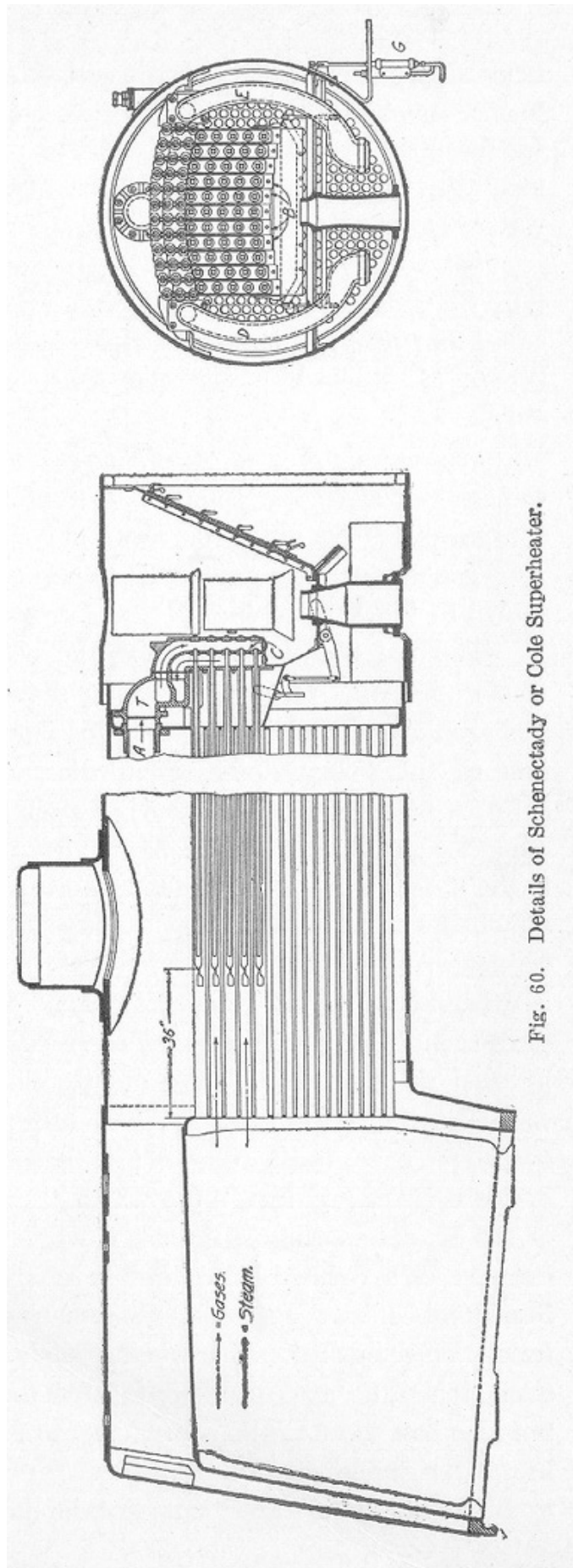

Fig. 60. Details of Schenectady or Cole Superheater.



products of combustion. In this particular design, fifty-five 3-inch tubes are employed, thus displacing as many of the regular smaller tubes as would occupy a similar space.

It is necessary to provide some means by which the superheater tubes shall be protected from excessive heat when steam is not being passed through them. In this instance, this is accomplished by the automatic damper shown in [Fig. 60](#). The entire portion of the smoke-box below the T-pipe and back of the header castings is completely enclosed by metal plates. The lower part of this enclosed box is provided with a damper which is automatic in its action. Whenever the throttle is opened and steam is admitted to the steam chest, the piston of the automatic damper cylinder *G* is forced upward and the damper is held open, but when the throttle is closed, the spring immediately back of the automatic damper cylinder closes the damper and no heat can be drawn through the 3-inch tubes. In this way, the superheater tubes are prevented from being burned. There is a slight loss of heating surface in introducing the group of 3-inch tubes and applying a superheater, but this loss is more than offset by the gain in economy due to the use of the superheated steam.

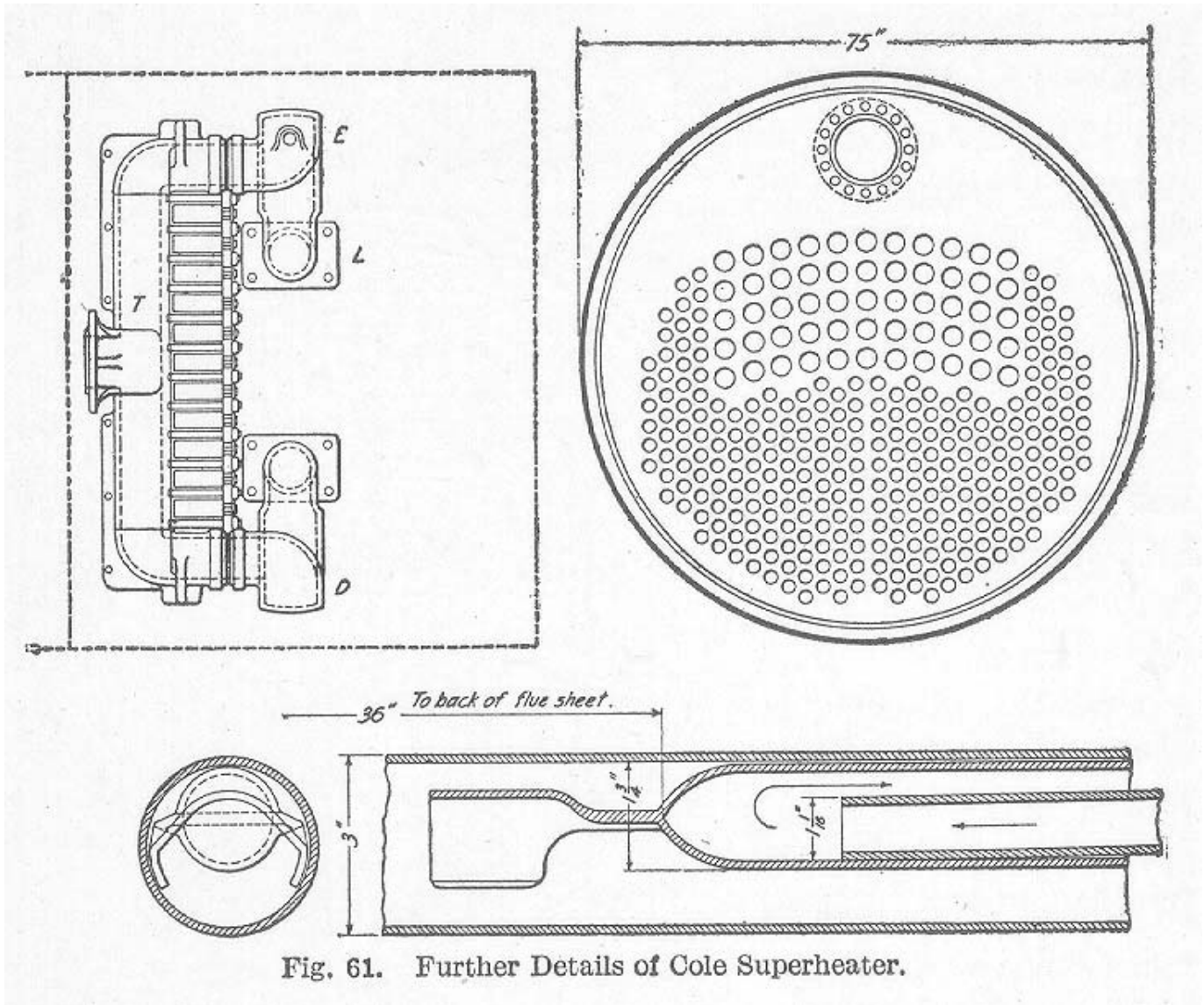

Fig. 61. Further Details of Cole Superheater.

The results of laboratory tests of the Schenectady superheater indicate a saving of from 14 to 20 per cent of water and from 5 to 12 per cent of coal.

*Baldwin Superheater.* The Baldwin superheater which is now being used by some railroads differs from the Schenectady and the Pielock superheaters in that it is found entirely within the smoke-box. It can be applied to any locomotive without disturbing the boiler and its application does not reduce the original heating surface.

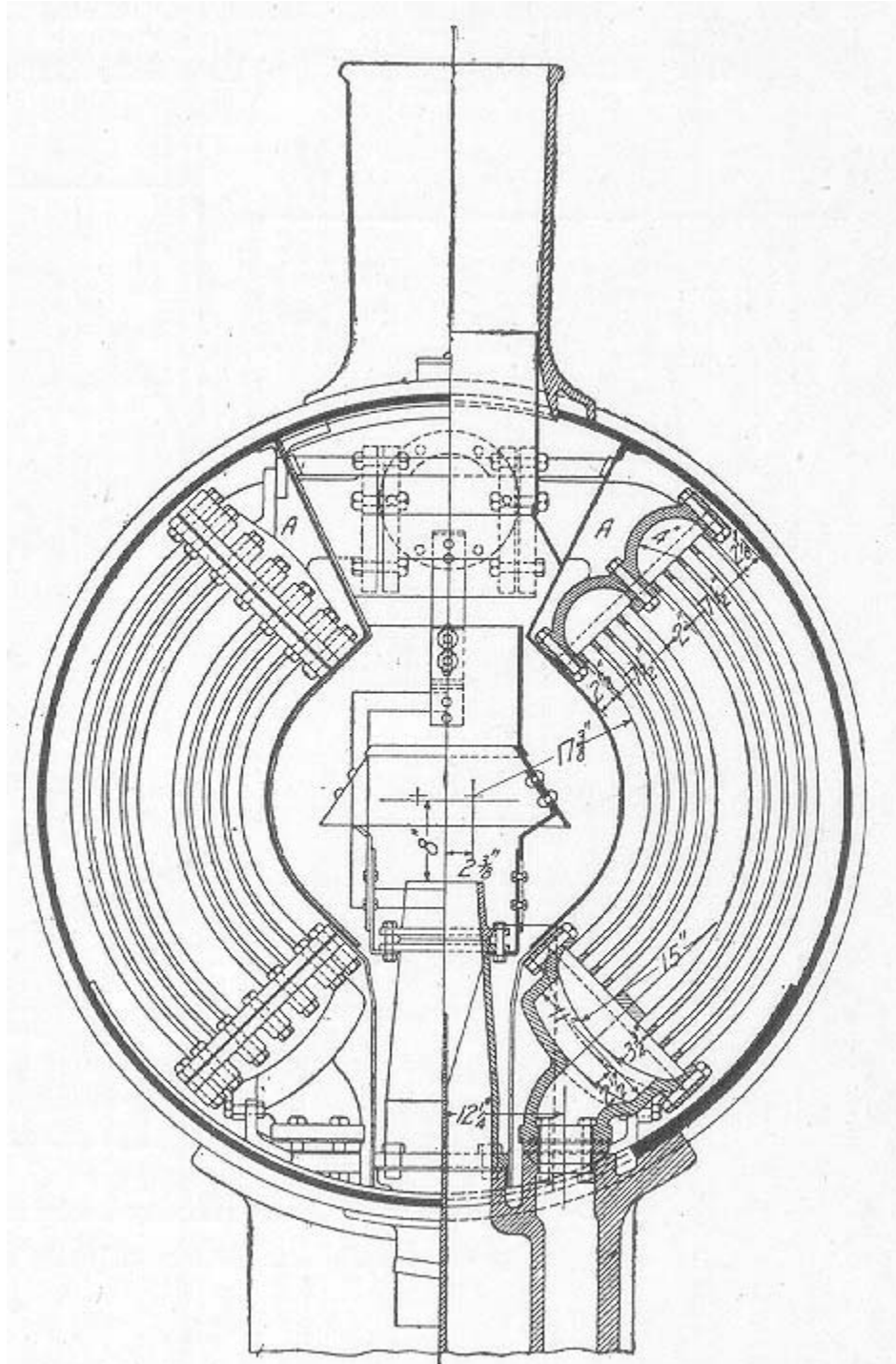

Fig. 62. Baldwin Superheater.



It consists of two cast-steel headers *A*, [Fig. 62](#), which are cored with proper passages and walls. These headers are connected by a large number of curved tubes which follow the contour of the smoke-box shell, and are expanded in tube plates bolted to the headers.

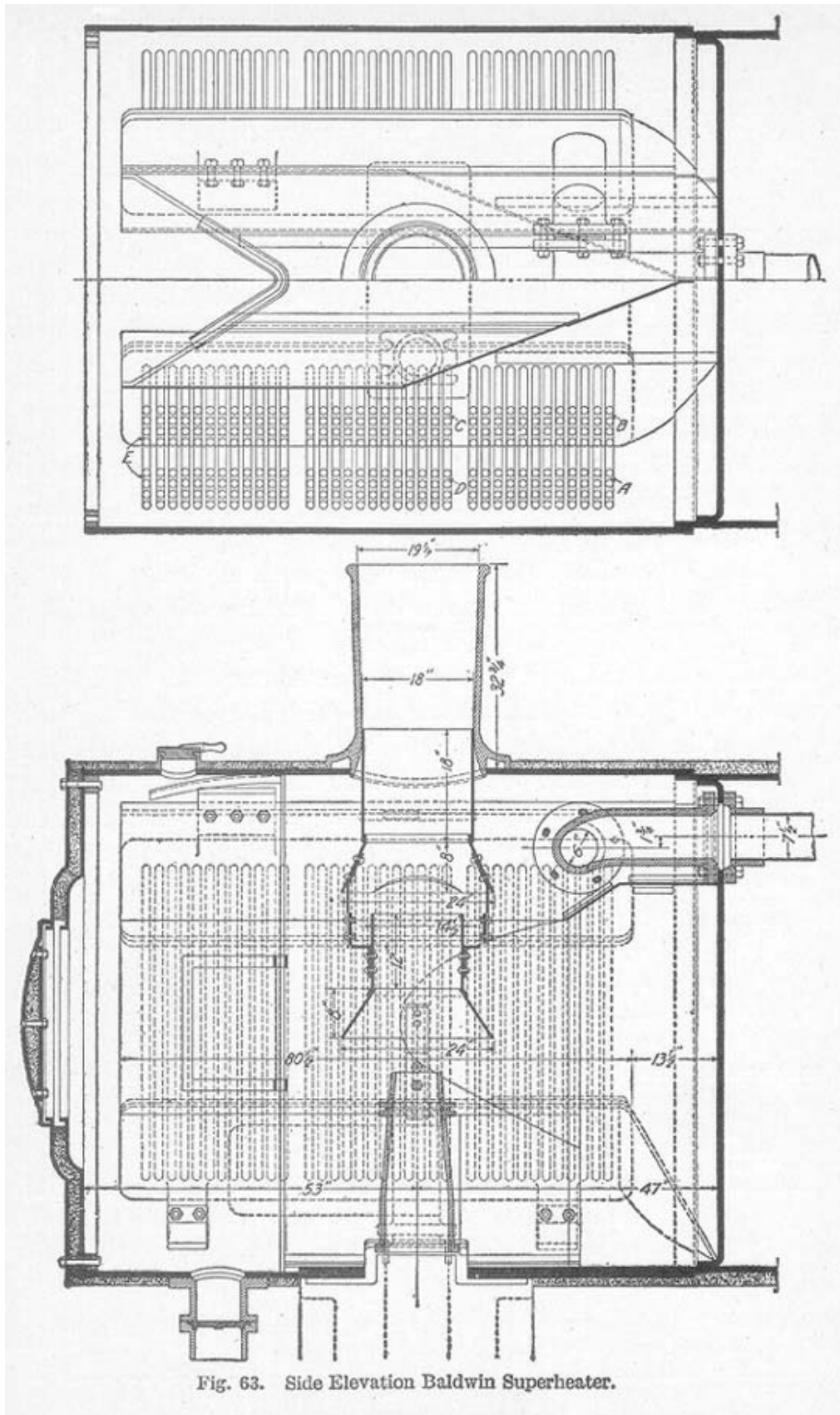

Fig. 63. Side Elevation Baldwin Superheater.

The curved tubes are divided into groups, the passages in the headers being so arranged that the steam after leaving the T-head on either side passes down through the group forming the outer four rows of the rear section of superheater tubes, then crosses over in the lower header and passes up through the inner group of the next section and up through the outer group and thence down through both the inner and outer groups of the forward section and through a passage-way in the lower header to the saddle. As illustrated in [Fig. 63](#), these tubes are heated by the gases from the fire tubes and the deflecting plates are so arranged as to compel these gases to circulate around the tubes on both sides to the front end of the smoke-box and thence back through the center to the stack. Thus, the superheater uses only such heat as is ordinarily wasted through the stack, and whatever gain in superheat is obtained, is clear gain.

Experiments so far made with this type of superheater show that while it is not possible to obtain a very high degree of superheat, yet enough is obtained to very decidedly increase the economy of the boiler. The front end is heavily lagged at all points to prevent as far as possible all loss of heat by radiation.

There have been several types of superheaters placed on the market in addition to those already mentioned, all having more or less merit. They differ in detail of construction but the principle embodied is covered by some one of the types described in the preceding pages.

*Superheater Tests.* Of recent years much experimental work has been done to ascertain the relative increase in economy obtained by the use of locomotives equipped with superheaters and to determine the increase, if any, in the maintenance of locomotives so equipped. In many instances the published data on the subject is presented in such a manner as to make comparisons rather difficult. The experiments conducted by Dr. Goss during the last few years have been of much interest to railroad men. The work was conducted on the Purdue locomotive, having a boiler designed to carry a working pressure of 250 pounds per square inch. The results obtained are very briefly summarized in Tables IV, V, VI, and VII.

**TABLE IV**

**Steam per Indicated Horsepower per Hour**

(Cole Superheater)

<b>Boiler Pressure in Pounds per Sq. In. Gage</b>	<b>Superheat in Degrees F.</b>	<b>Pounds Steam per I.H.P. per Hour Saturated Steam</b>	<b>Pounds Steam per I.H.P. per Hour Superheated Steam</b>	<b>Saving in Per Cent by Use of Superheated Steam</b>
240	139.6	24.7	22.6	8.50
220	145.0	25.1	21.8	13.14
200	150.3	25.5	21.6	14.51
180	155.6	26.0	21.9	15.77
160	160.8	26.6	22.3	16.16
140	166.1	27.7	22.9	17.32
120	171.4	29.1	23.8	18.21

**TABLE V****Coal per Indicated Horsepower per Hour**

(Cole Superheater)

<b>Boiler Pressure in Pounds per Sq. In. Gage</b>	<b>Pounds Dry Coal per I.H.P. per Hour Saturated Steam</b>	<b>Pounds Steam per I.H.P. per Hour Superheated Steam</b>	<b>Saving in Per Cent by Use of Superheated Steam</b>
240	3.31	3.12	5.74
220	3.37	3.00	10.98
200	3.43	2.97	13.41
180	3.50	3.01	14.00
160	3.59	3.08	14.21
140	3.77	3.17	19.51
120	4.00	3.31	17.27

**TABLE VI****Steam per Indicated Horsepower per Hour**

(Schmidt Superheater)

<b>Boiler Pressure in Pounds per Sq. In. Gage</b>	<b>Superheat in Degrees F.</b>	<b>Pounds Steam per I.H.P. per Hour Saturated Steam</b>	<b>Pounds Steam per I.H.P. per Hour Superheated Steam</b>	<b>Saving in Per Cent by Use of Superheated Steam</b>
240	222.2*	24.7	19.5*	21.05
220	226.5*	25.1	19.0*	24.30
200	230.8	25.5	18.9	25.89
180	235.1	26.0	18.7	28.08
160	239.4	26.6	18.9	28.94
140	243.8	27.7	19.5	29.60
120	248.6	29.1	21.0	27.83

\*Results estimated for making comparisons.

**TABLE VII**

**Coal per Indicated Horsepower per Hour**

(Schmidt Superheater)

<b>Boiler Pressure in Pounds per Sq. In. Gage</b>	<b>Pounds Dry Coal per I.H.P. per Hour Saturated Steam</b>	<b>Pounds Steam per I.H.P. per Hour Superheated Steam</b>	<b>Saving in Per Cent by Use of Superheated Steam</b>
240	3.31	2.63*	20.54
220	3.37	2.57*	23.74
200	3.43	2.55	25.65
180	3.50	2.51	28.28
160	3.59	2.55	28.97
140	3.77	2.63	30.24
120	4.00	2.89	27.75

\*Results estimated for making comparisons.

The results presented in Tables IV to VII were all obtained at a uniform speed of 30 miles per hour, and may be briefly stated as follows:

(a) With the locomotive equipped with a Cole superheater a saving was effected, over values obtained with saturated steam, in steam used per I.H.P. per hour of from 8.5 to 18.21 per cent and in coal per I.H.P. per hour of from 5.74 to 17.25 per cent.

(b) With the locomotive equipped with a Schmidt superheater the saving of steam used per I.H.P. per hour varied from 21.05 to 29.60 per cent, while the saving in coal used per I.H.P. per hour varied from 20.54 to 30.24 per cent.

(c) The superheat in the branch pipe just before entering the cylinders, varied from 139.7 to 171.4 degrees F., when the Cole superheater was used, and from 222.2 to 248.6 degrees F., when the Schmidt superheater was used,

The higher efficiency obtained of the Schmidt superheater over the Cole superheater is partially accounted for by the fact that the total heating surface of the Schmidt amounted to 325 square feet, while that of the Cole was only 193 square feet.

In conclusion, it may be stated that the superheating simple locomotive will reduce the steam and coal consumption to that required by the compound locomotive. It will operate efficiently on comparatively low steam pressures, and its maximum possible power is considerably beyond that of the simple locomotive using saturated steam. Many complaints have been made by operators relative to difficulty experienced in securing proper lubrication of the valve, etc., when using superheated steam. It has been demonstrated, however, that this difficulty can be overcome by the exercise of good judgment in the use of and proper amount and grade of lubricating oil.

**Locomotive Boiler Design.** The design of locomotive boilers and engines is a very deep subject-one requiring much thought and study. Limited space prevents going into a discussion of the reasons for the adoption of different designs. The following formulae

for the calculation of thickness of plates, spacing of rivets, etc., are given. Some of these formulae, while being semi-empirical, are based on theoretical assumptions and represent modern practice in the design of parts mentioned. In figuring the thickness of the boiler shell, the following formula is given:

$$t = \frac{P D f}{2 T E}$$

where

$t$  = thickness of shell in inches

$P$  = steam pressure, pounds per square inch

$D$  = inside diameter of shell in inches

$f$  = factor of safety, usually taken not less than  $4\frac{1}{2}$

$T$  = tensional strength of plate in pounds per square inch, usually taken as 55,000

$E$  = efficiency of longitudinal joint expressed as a decimal fraction which may be taken as .85

*Example.* In a given locomotive boiler, the first ring is 60 inches in diameter; the steam pressure is 200 pounds. Required the thickness of the plate.

SOLUTION.

$$\begin{aligned} t &= \frac{200 \times 60 \times 4.5}{2 \times 55000 \times .85} \\ &= .57 \text{ inches} \end{aligned}$$

The efficiency of the joint is expressed as follows:

$$E = \frac{\text{Tearing resistance of joint}}{\text{Tearing resistance of solid plate of same dimensions}}$$

or

$$E = \frac{\text{Shearing resistance of joint}}{\text{Shearing resistance of solid plate of same dimensions}}$$

NOTE: Use whichever value is the least.

In computing the thickness of the conical connection in a boiler shell use the formula

$$t = \frac{P D f}{2 T E}$$

the inside diameter at the large end being considered.

In calculating the thickness of the fire-box side and fire-door sheets, the following formula may be used:

$$t = \sqrt{\frac{2 a^2 P}{49500}}$$

where  $a$  = the pitch of stay-bolts in inches.

The pitch of the stay-bolts may be taken as

$$a = \sqrt{\frac{49500 t^2}{2 P}}$$

*Example.* Determine the thickness of the side sheets when the steam pressure employed is 200 pounds per square inch and the stay-bolts are spaced 4 inches from center to center.

SOLUTION.

$$t = \sqrt{\frac{2 \times 4^2 \times 200}{49500}}$$
$$= .36 \text{ inches}$$

The safe tensile strength of stay-bolts should be taken not to exceed 5,500 pounds per square inch.

The diameter of rivets may be determined by the following formula:

$$d = 1.2 \sqrt{t}$$

The following standard thicknesses of plates are used in locomotive boiler construction: Crown sheet, side sheet, and back fire-box sheet, 3/8 inch in thickness; for boiler pressures not exceeding 200 pounds, the boiler head, roof, sides, and dome, 1/2 inch thick, while for boilers with steam pressures between 200 and 240 pounds, these plates are 9/16 inch thick.

In designing the riveted joints, their strength must be considered from several different standpoints. It must be sufficiently strong to withstand the tensional stress on the metal contained in the plate between the rivets. The plates must be of such thickness as will safely carry the compressional stresses behind the rivets and the rivets must be placed in rows sufficiently far apart and far enough from the edge of the plate to insure against shearing or tearing out of the metal. In the formulae for the design of a riveted joint, the following notation will be used:

$d$  = diameter of rivet hole in inches

$p$  = pitch or distance in inches between center to center of rivets

$t$  = thickness of plate in inches

$h$  = distance in inches from edge of plate to center of first rivet hole

$T$  = tensile strength of plate in pounds per square inch, usually taken as 55,000

$S$  = shearing strength of rivets in pounds per square inch, usually taken as 55,000



$R$  = shearing strength of plate in pounds per square inch, usually taken as 45,000 pounds per square inch

$C$  = crushing strength of plate in pounds per square inch, usually taken as 50,000 pounds per square inch

$f$  = factor of safety usually taken not less than 4-1/2

The safe resistance in pounds per square inch offered by one rivet to shear

$$= .7854 d^2 \frac{S}{f}$$

The safe resistance in pounds per square inch offered to tearing of plate between rivet holes

$$= (p-d) t \frac{T}{f}$$

The safe resistance to crushing in pounds per square inch of the portion of the plate in front of rivet

$$= \frac{t d C}{f}$$

The safe resistance to shearing out in pounds per square inch of that portion of the plate in front of the rivet

$$= \frac{2 h t R}{f}$$

**Boiler Capacity. Importance.** In the early days of the locomotive very little attention was given to the size of the boiler. If the cylinders were large enough to pull a train of reasonable size up the maximum grade and the driving wheels were loaded sufficiently to prevent slipping, the results secured were generally considered satisfactory. Today, however, conditions are changed. Now the capacity of the locomotive boiler for the generation of steam is looked upon as the most important feature in connection with the design of a locomotive and, as a rule, the boiler is made as large as possible, consistent with total weight desired. Wherever possible the weight of parts is reduced in order to favor the boiler. It is now known that no locomotive was ever impaired in any way by having a boiler that steamed too freely, for the greater the boiler capacity the greater the speed that can be maintained. As the demand for speed and the loads hauled increased, it was soon discovered that the speed of a train of a given length and weight was limited by the capacity of the boiler. Complaints were made of the boiler "not steaming", and, although the insufficient supply of steam might have been attributed to an inferior grade of fuel, improper firing, bad adjustment, "front end" arrangement, flues in bad condition, or negligence in the manipulation of the engine, it soon became recognized that, with all boiler conditions in perfect order and the locomotive operated by experienced men, it was impossible to make a small boiler supply a sufficient amount of steam for large cylinders operating at high rates of speed. As a result the boiler gradually grew in size, and with it a desire to arrive at a rational proportioning of its various parts, such as heating surface, grate area, length of tubes, etc., necessary to maintain a definite tractive effort at a definite speed.

*Effect of Area of Heating Surface.* All the various dimensions of the different parts of the boiler are more or less important in their relation to the question of steam generation. Perhaps the most important of these are the dimensions of the heating surface. The area of the grate surface limits the amount of coal that can be burned in a given time, but the amount of coal burned per unit of heating surface governs, to a great extent, the rate of evaporation. Concerning the rate of combustion per square foot of heating surface, it is found that the same condition exists as in stationary boiler practice, namely, that the lower the rate of combustion the greater the evaporation per pound of coal.

*Effect of Tube Length.* The capacity of the boiler is also affected to a certain extent by the length of the tubes. It was found in a series of extensive experiments conducted in Europe a number of years ago that the most economical length of tubes was 14 feet. This length was found with a draft in the fire-box of 3 inches of water. In the United States a much higher draft is employed and for this reason much longer tubes can be used. Tubes over 20 feet in length are now quite common. As long as the temperature of the gases in the smoke-box is above that corresponding to the pressure of steam in the boiler there will be heat transferred from the front end of the tubes to the water in the boiler. Increasing the length of the tubes will, of course, reduce the draft in the fire-box and, as a result, the amount of coal burned will be reduced. For this reason the tubes should be of a definite length for maximum efficiency.

*Effect of Scale.* The transmission of heat through the tubes and fire-box sheets is dependent to a large extent on the condition of the inner surfaces. If they are covered with a thin layer of scale, the heat transmitted will be materially reduced. Experiments conducted in 1898 on the Illinois Central Railroad gave some very interesting results on the effect of scale on the steaming capacity of a locomotive boiler. Tests were first made on a locomotive which had been in service 21 months. After the test the engine was sent to the shops and received new tubes and a thorough cleaning. The total weight of scale removed from the boiler was 485 pounds and it had an average thickness on the principal heating surfaces of  $\frac{3}{64}$  inch. After the engine had received the cleaning and new tubes, a second test was conducted in which the same coal per square foot of heating surface was burned as in the first test. The result of the second test showed the steam-making capacity of the boiler to have been increased 13 per cent.

*Effect of Radiation.* The loss of heat from the outer surface of a locomotive boiler by radiation and the ultimate effect on its capacity are items worthy of consideration. The heat lost in this manner is so great with an unprotected boiler shell that it is necessary to use some form of insulating material to minimize the loss. Covering a boiler with insulating material is more necessary with high pressure than with low pressure because of the greater temperature difference. Results of tests of boiler covering reported to the Master Mechanics' Association in 1898 show that a loss of 0.34 B.t.u. per square foot of radiating surface per hour per degree difference in temperature was obtained by the use of mineral wool, while under the same conditions with a lagging of wood and sheet iron the loss was increased to 1.10 heat units. In both cases the temperature difference was reckoned between the temperature of the steam in the boiler and that of the surrounding air. The results show a saving of 0.76 B.t.u. in favor of the mineral wool lagging. Let us consider a boiler carrying steam at 200 pounds per square inch gage pressure, which represents a temperature of 388° F. Assuming the temperature of the atmosphere to be 32° F., this represents a temperature difference of 356 degrees. Assume further a locomotive boiler having an outside surface of 600 square feet. The heat of vaporization

per pound of steam at 200 pounds per square inch gage pressure is 838 B.t.u. The pounds of steam condensed in the boiler per hour due to radiation in case a wood lagging is used, in excess of the amount that would be condensed if mineral wool were used, is equal to

$$\frac{0.76 \times 600 \times 356}{833} = 193$$

Assuming that the steam consumption per i.h.p.hr. is 20 pounds, the above figure represents 9.6 horsepower.

The foregoing figures represent results obtained in still air. The radiation losses are increased very much when the locomotive is in service. This fact is demonstrated by the results of tests conducted on the Chicago and Northwestern Railway in 1899. The locomotive employed had 219 square feet of covered boiler surface and 139 square feet uncovered. Assuming, for this type of engine, the steam consumption per i.h.p.hr. to be 26 pounds, the results of the tests showed a condensation representing a horsepower of 4.5 when at rest and 9 when being pushed at a rate of 28 miles per hour.

*Boiler Horsepower.* In the foregoing we have considered the determination of the greatest amount of steam which a locomotive boiler can produce and it is evident that the boiler capacity limits the work that can be performed by the engine. Under some circumstances it is more convenient to express the boiler capacity in terms of an evaporative unit. The term "boiler horsepower" is such a unit, but the use of this expression is sometimes misleading in speaking of the capacity of a locomotive, for a given boiler will produce a greater horsepower with a compound than with a simple engine and with an early and economical cut-off than with a later and more wasteful one.

*A boiler horsepower,* as defined by the American Society of Mechanical Engineers, is the production of 30 pounds of steam per hour at a gage pressure of 70 pounds per square inch evaporated from a feed-water temperature of 100° F. This is considered equivalent to the evaporation of 341-1/2 pounds of water per hour from a temperature of 212° F. into steam at the same temperature.

# LOCOMOTIVE BOILERS AND ENGINES

## PART II

### THE LOCOMOTIVE ENGINE

In studying the conditions affecting the performance of the engine proper, the amount of lead, outside lap, and inside clearance must be taken into consideration.

**Lead.** By *lead* is meant the amount the steam port is open when the engine is on *dead center* or when the piston is at the beginning of its stroke. This amount varies from 0 to  $\frac{1}{4}$  of an inch in practice. By having the proper amount of lead, a sufficient amount of steam behind the piston is assured at the beginning of the stroke and assists in maintaining the steam pressure until the steam port is closed and the steam is thereby cut off. It also serves to promote smooth running machinery. Any admission of steam behind the piston before the end of the stroke results in negative work, hence the amount of lead should be limited and largely controlled by the speed of the machine.

**Outside Lap.** By the term *outside lap* is meant the amount the valve overlaps the outside edges of the steam ports when it is in its central position. One of the effects of increasing outside lap is to cause cut-off to take place earlier in the stroke, other conditions remaining unchanged. If, however, the amount of lap is increased and it is desired to maintain the same cut-off, the stroke of the valve must be increased. Within certain limits, outside lap increases the rapidity with which the valve opens the steam port, resulting in a freer admission of steam. The range of cut-off is decreased as the lap is increased, other conditions remaining the same.

When the cut-off is short, the exhaust is hastened, an effect which diminishes as the cut-off is lengthened. The amount by which the steam port is uncovered by the exhaust cavity of the slide valve is increased as the cut-off is shortened. Other things remaining constant the changing of any one of the events of stroke causes a corresponding change to a greater or less degree of each of the other events.

**Inside Clearance.** By the expression *inside clearance* is meant the amount the steam port is uncovered by the exhaust cavity of the valve when the valve is in its central position. Formerly it was customary to have an inside lap of about  $\frac{1}{16}$  of an inch but in recent years in the development of engines which require a free exhaust at high speeds, the inside lap was reduced until now there is in some cases from  $\frac{1}{8}$  to  $\frac{3}{16}$  inches inside clearance. The effect of changing a valve from inside lap to inside clearance, other things remaining unchanged, is to hasten release and delay compression and hence to increase the interval in which the exhaust port remains open. It also permits a greater extent of exhaust port opening. As a consequence, the exhaust is freer and the back pressure is reduced, giving an advantage in the operation of the engine, which is desired at high speeds. Experiments have shown that an increase in inside clearance for high speeds will bring about an increase in the power of the locomotive, but an increase in inside clearance at slow speeds entails a loss of power and a decrease in efficiency. The loss in power at low speeds, due to inside clearance, is greater at short cut-offs and diminishes as

the cutoff is increased. Tests have shown that at moderate speeds, say, 40 to 50 miles per hour, all disadvantages are overcome.

## VALVE MOTION

**Requirements.** The valve motion of a locomotive engine must meet the following regulations:

1. It must be so constructed as to impart a motion to the valve which will permit the engine to be operated in either direction.
2. It must be operative when the engine is running at a high or low speed and when starting a heavy load.
3. It should be simple in construction and easily kept in order.

A number of valve gears have been developed which fulfill these requirements more or less satisfactorily, such as the Stephenson, the Walschaert, the Joy, and the fixed link, the Stephenson gear being the one most commonly used in the United States. A study will be made of the Stephenson and Walschaert gears, the latter resembling in some respects the Joy valve gear. The Walschaert gear has been extensively used in Europe for many years and of late years has become quite common in America. There are a few modifications of the Stephenson gear which have been made to meet structural requirements but the great majority of American engines are fitted with a device as illustrated in [Fig. 64](#). The action of this device is fully explained in the article on "Valve Gears."

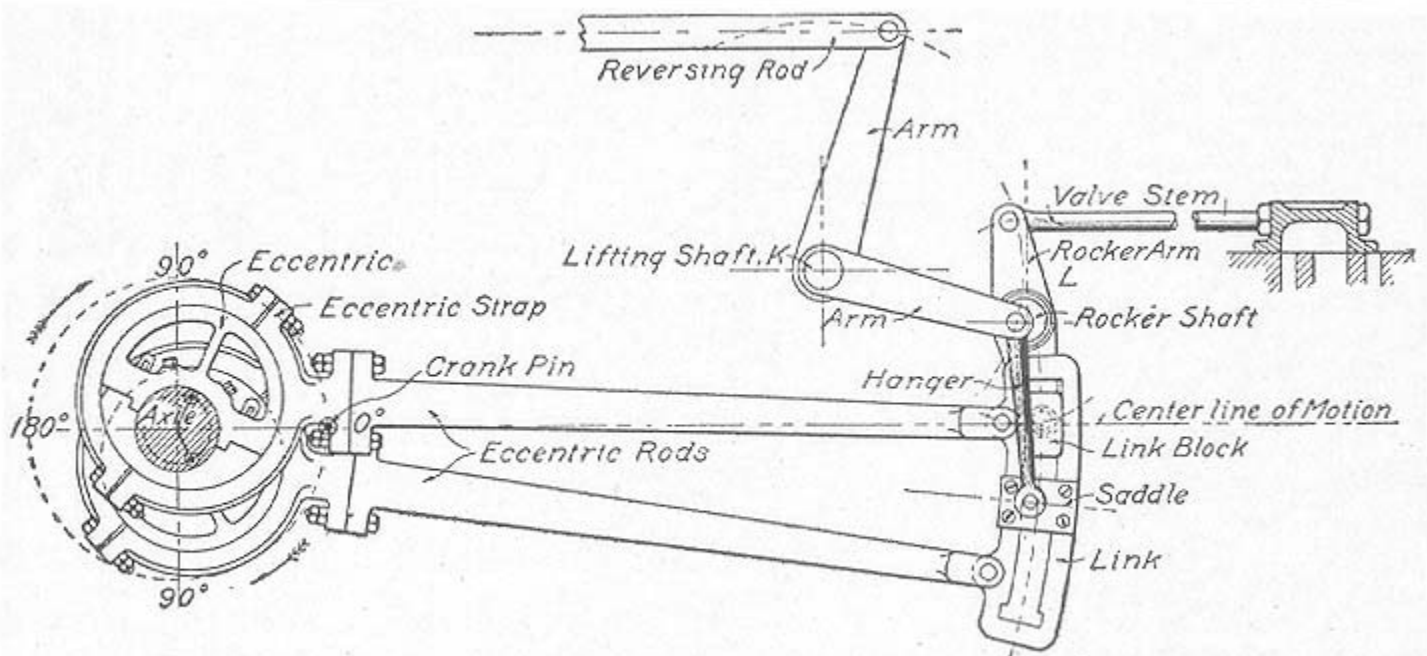

Fig. 64. Standard Stephenson Valve Gear.

**Stephenson Valve Gear.** The Stephenson gear consists of the reverse lever, reach rod, lifting shaft, link hanger, link, eccentric, and rocker arm.

The *reversing lever* is given a variety of forms, a good design of which is illustrated in [Fig. 65](#). The lever is pivoted at *A*, below the floor of the cab and can be moved back and

forth beside the quadrant *B* to which it can be locked by means of the latch *C*. This latch is held down by a spring surrounding the rod *D*, acting on the center of the equalizer *E*. This makes it possible to use very fine graduations of the quadrant and by making the latch as shown, the cut-off can be regulated by practically what amounts to half notches.

The *reach rod*, or *reversing rod*, is fastened to the reversing lever at *F* and consists of a simple piece of flat iron having a jaw at one end by which it serves to connect the reversing lever and the lifting shaft *K*, shown in [Fig. 64](#).

The *lifting shaft*, shown at *K*, [Fig. 64](#), consists of a shaft held in brackets usually bolted to the engine frames to which are connected three arms, one being vertical and to which is attached the reach rod, and two horizontal ones from which the links are suspended.

The *link hanger* is a flat bar with a boss on each end. It carries the link by means of a pin attached to the link saddle, illustrated in [Fig. 64](#).

The *link*, [Fig. 64](#), is an open device held by the saddle and fitted with connections for the eccentric rod.

The *eccentrics*, [Fig. 64](#), usually of cast iron, are fitted to the main driving axle.

The *rocker arm*, [Fig. 64](#), consists of a shaft to which two arms are connected, the lower one of which is attached to the link block and the upper to the valve stem.

*Setting the Valves.* This is a comparatively simple operation but one requiring great care. On account of the angularity of the rods, it is impossible to adjust any link motion to give equal cut-off at all points for both strokes of the piston. The most satisfactory arrangement is one which provides for an equalization of the lead and cut-off at mid-gear. But even this will cause a variation of cut-off of from  $\frac{3}{8}$  to  $\frac{1}{2}$  of one per cent in the full gear part of the cut-off and at other points.

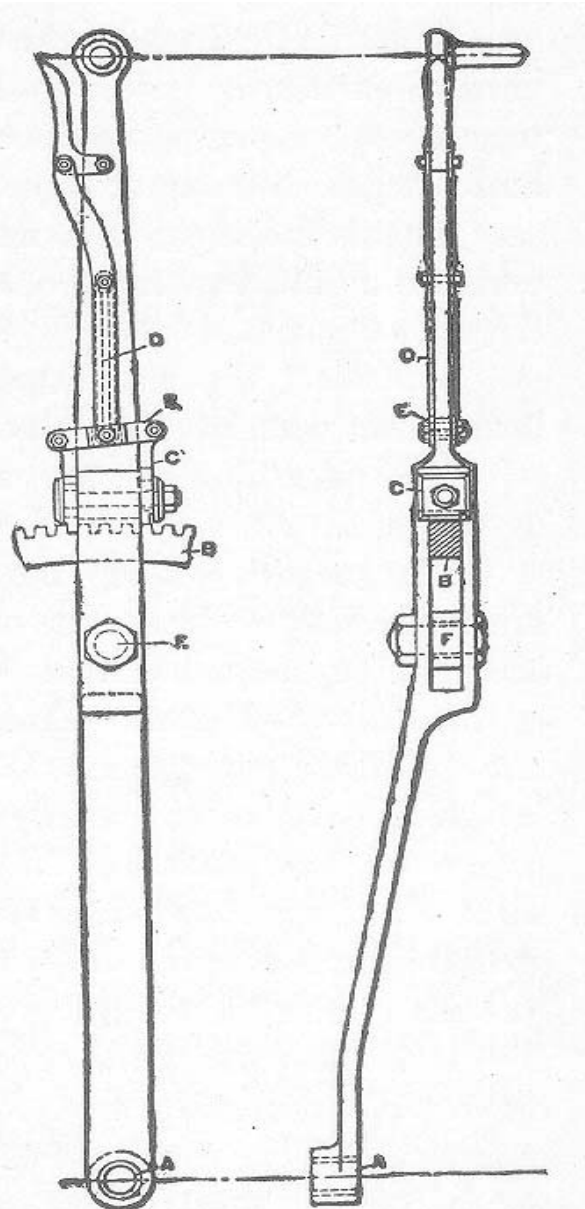

Fig. 65. Reversing Lever.



In setting the valves upon a locomotive, some means must be employed for turning the main driving wheels. This is usually accomplished by mounting the main drivers upon small rollers which can be turned by a ratchet or motor without moving the locomotive as a whole. If a set of rollers are not available, the locomotive may be moved to and fro by using pinch bars.

Before undertaking the setting of the valves, the length of the valve rod must be adjusted. To do this, set the upper rocker arm vertical if the valve seat is horizontal; if inclined, the rocker arm must be placed perpendicular to the plane of the valve seat. Next adjust the length of the valve rod so that it will connect with the rocker arm and the valve when the valve is in its central position. The next step is to locate the dead center points which points give the position of the crank on the dead center. It is very essential that this be done very accurately since a small movement of the crank at this position moves the piston but very little while the same movement causes a comparatively large movement of the valve. Hence, if the dead center points are not accurately located, the valves will not be set so accurately as they otherwise would be. To locate the dead center points, proceed as follows: First, secure a tram *d* as shown in [Fig. 66](#). This tram should be made of a steel rod about 1/4 inch in diameter having each end pointed, hardened, and tempered so as to retain a sharp point. With a center punch, make a center *e* on some fixed portion of the frame in such a position that when one point of the tram is in the

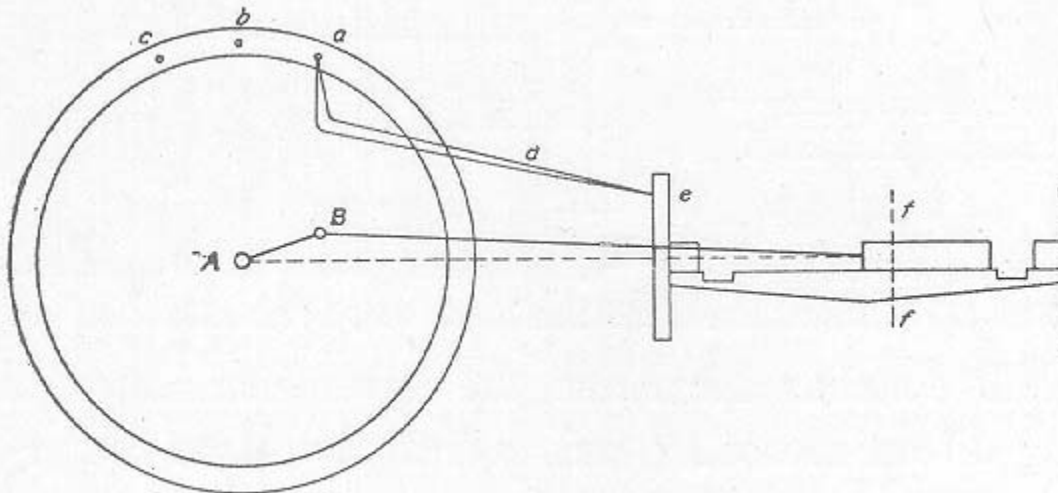

Fig. 66. Diagram for Locating Dead-Center Points.

center *e*, the other pointed end can be made to describe lines on the main driver. To locate the forward dead center, turn the driver ahead until the crank has almost reached the center line as shown in the position *AB*, [Fig. 66](#); that is, when the crosshead is, say, 1/2 inch from the extreme point of its travel. With the parts in this position, place the tram point in *e* as shown and locate the point *a* on the driver, and describe the line *ff* on the crosshead and guide. Next turn the driver ahead until the crank passes the dead center and the lines *ff* again coincide, when a second point *c* is marked by means, of the tram at the same distance from the center of the axle as the point *a*. With a pair of dividers locate the midposition *b* between *a* and *c*. In setting the valves for the head end, the required dead center will be located when one tram point is in the center *e* and the other in the center *b*. The dead-center point for the back stroke is located in the same manner as just described. An attempt to place the engine on dead center by measurements taken on the crosshead alone would likely result in an error, since the crank might move through an appreciable angle while passing the dead center and the consequent movement of the crosshead be

inappreciable, hence the advisability of using the more exact method explained above is made apparent.

The reverse lever and all the parts having been connected, to set the valves for forward gear, the procedure is as follows: Place the reverse lever in its extreme forward position. When this is done turn the engine ahead until the valve is just beginning to cut off, as shown at *l*, [Fig. 67](#). When this point is reached, stop the engine and make a small punch mark such as *a* on the cylinder casting. Then put one end of the tram *b* into the punch mark and describe an arc *c e* on the valve stem. Next turn the driver ahead until the valve is just cutting off on the other end. With the same center *a* as used before, describe another arc *f g* on the valve stem. These two arcs are known as the port lines and are to be the reference lines for the work which follows. Draw a straight horizontal line *H I* on the valve stem and where it intersects the arcs, make the center marks *A B*. The center *A* is the front port mark and the center *B* the back port mark. Next, place the reverse lever in the extreme backward position and locate points on the valve stem similar to the points *A* and *B*.

To avoid confusion, it is better to make all tram marks for the forward movement above the line *H I* and all those for the backward motion below.

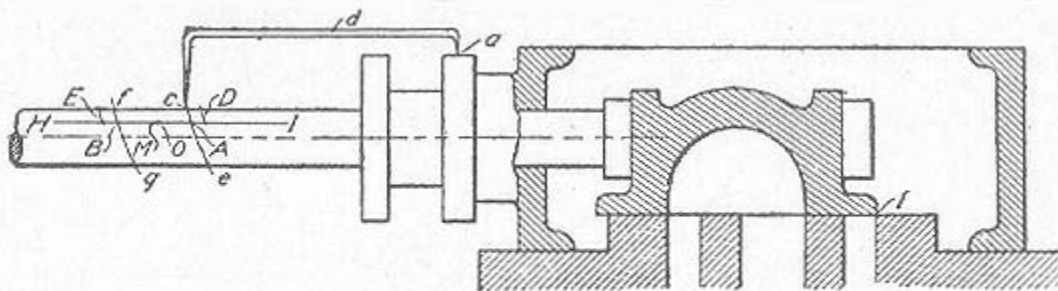

Fig. 67. Illustration of Method of Setting Locomotive Valves.

In trying the forward movement of the valve, see that the reverse lever is in the extreme forward position, then by running the engine ahead, place the crank in turn on each dead center, and describe an arc on the valve stem. In trying the valve for the backward gear, place the reverse lever in its extreme back position and by running the engine backward, place the crank on each dead center and describe arcs on the valve stem as before. In either case, if the dead center is past, do not back up to it but either make another revolution of the engine or back beyond it some distance, then approach it from the proper direction. This must be done in order to eliminate all lost motion.

These trial tram lines should be compared with the port marks when the engine is placed in the forward and backward gear.

If the trial tram lines fall outside of the port marks, so much lead is indicated, while if they fall within the port marks, so much negative lead is indicated.

It is customary for railroad companies to set the valves on their locomotives to give equal lead. The method commonly employed is presented herewith. Having the reverse lever in the extreme forward notch, run the engine ahead, stopping it on the forward dead center. With the tram *b* in the center *a*, [Fig. 67](#), describe the arc *D* above the line *H I*. Next turn the engine ahead until the back dead center is reached; using the tram *b* again with a

center at  $a$ , describe the arc  $E$  above the line  $HI$ . With dividers, find a mid-point  $O$  between  $E$  and  $D$ . If the center  $O$  is ahead of the point  $M$ , which is midway between the port marks  $A$  and  $B$ , the eccentric blades which control the forward motion must be shortened an amount equal to the distance between  $M$  and  $O$ . When this is done, the lead will be equalized. If it is desired to increase the lead, move the forward eccentric toward the crank. To decrease the lead, move the forward eccentric away from the crank. After all of these changes have been made, repeat the operation in order to check the results. If this does not give the desired results, correct the error by repeating the process and continue by trial until the conditions sought for are obtained.

To set the valves for the back motion, proceed in the same manner as that described for the forward motion, all the changes being made on the eccentric blades and eccentric which control the backward motion.

In all that has been said regarding the setting of the Stephenson valve gear, it is assumed that the gear is one having open rods; that is, one in which the rods are open, not crossed when the eccentrics face the link.

**Walschaert Valve Gear.** The Walschaert valve gear is illustrated by the line diagram in [Fig. 68-a](#). [Fig. 68-b](#) shows its application to a Consolidation freight locomotive. From a study of [Fig. 68-a](#) it is obvious that the motion of the valve is obtained from the crosshead and an eccentric crank attached to the main crank pin. In some designs, the eccentric pin is replaced by the usual form of eccentric attached to the main driving axle. The crosshead connection imparts a movement to the valve which in amount equals the lap plus the lead when the crosshead is at the extremities of the stroke, in which position the eccentric crank is in its mid-position. The lead of the valve is constant and can only be changed by altering the leverage relation of the combination lever. The eccentric crank actuates the eccentric rod which, in turn, moves the link to and fro very much the same as does the eccentric blade in the Stephenson gear. There is a radius bar, [Fig. 68-a](#), which connects the link block with the valve stem. It is evident, therefore, that the valve obtains a motion from the eccentric crank, link, radius bar, and valve rod in a manner similar to the Stephenson, the main difference being in the crosshead connection which results in giving the valve a constant lead.

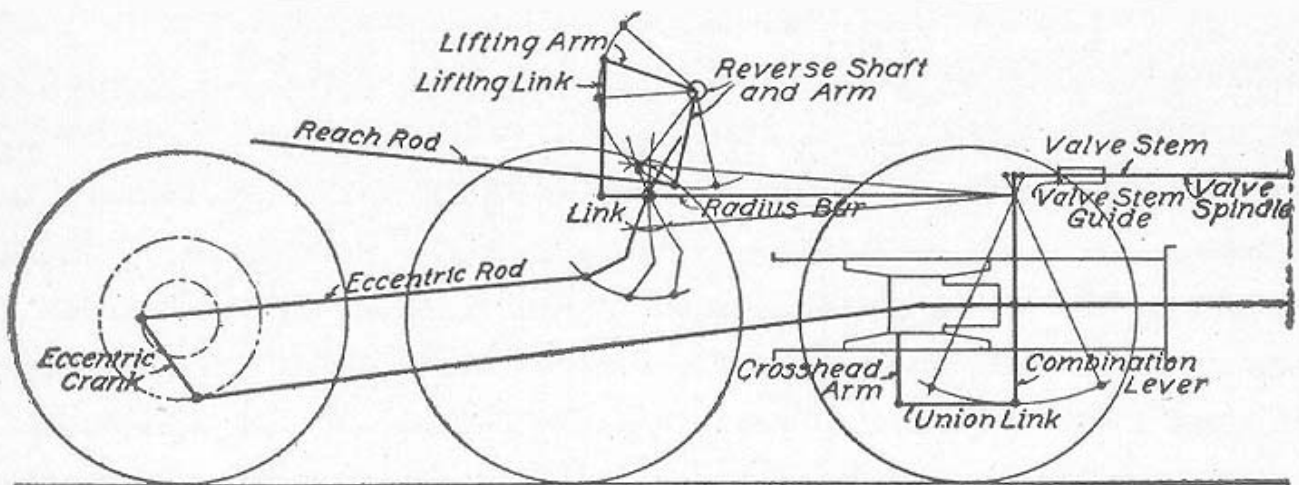

Fig. 68-a. Diagram of Walschaert Valve Gear.

It is to be noted that in a valve having internal admission, the radius bar connects with a combination lever above the valve rod connection, as shown in [Fig. 68-b](#), and that in a valve having external admission, the connection is made below the valve rod, as illustrated in [Fig. 68-a](#); also, in a valve having internal admission, the eccentric crank follows the main crank, while in a case where the valve has external admission, it precedes the main crank. Theoretically, the eccentric crank is 90 degrees from the main crank but because of the angularity of the eccentric rod, it is usually two or three degrees more.

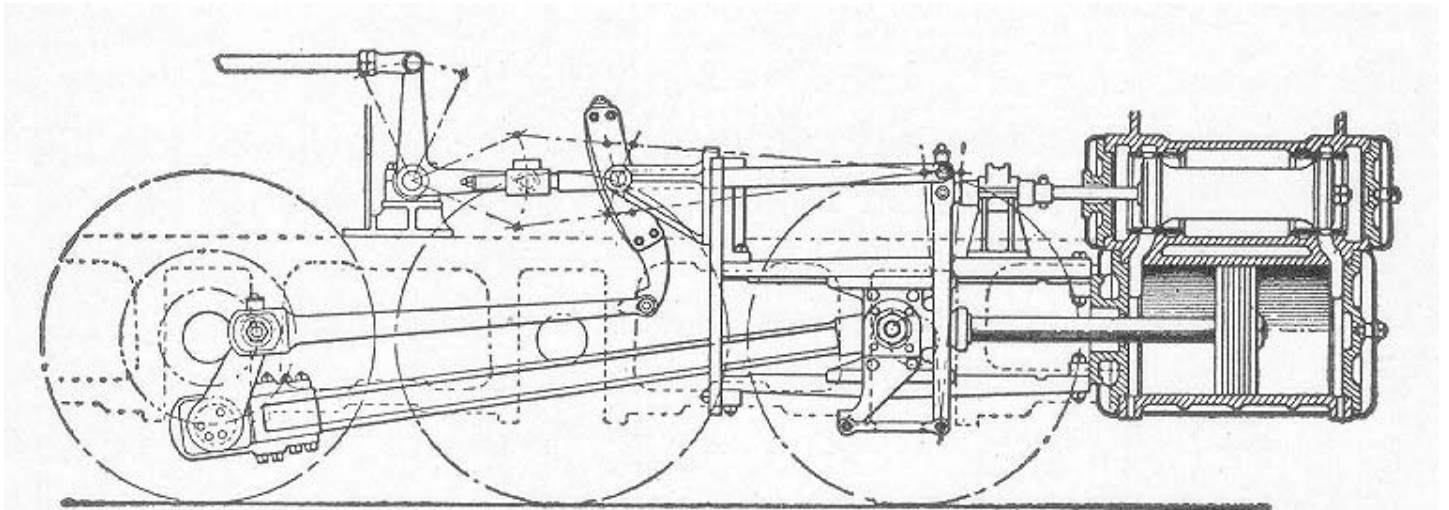

Fig. 68-b. Walschaert Gearing Mounted on a Consolidation Locomotive.

The Walschaert gear is operated by a reverse lever in the same manner as the Stephenson gear. In the Stephenson gear, a movement of the reverse lever causes the link to be raised or lowered, the link block remaining stationary, whereas in the Walschaert gear, the link remains stationary and the link block is raised or lowered. From a study of the two gears, it may be stated that the chief point of difference is that the Walschaert gives a constant lead for all cut-offs, whereas the Stephenson gives a different lead for different cut-offs. The following steps given by the American Locomotive Company for adjusting the Walschaert valve gear are presented:

1. The motion must be adjusted with the crank on the dead centers by lengthening or shortening the eccentric rod until the link takes such a position as to impart no motion to the valve when the link block is moved from its extreme forward to its extreme backward position. Before these changes in the eccentric are resorted to, the length of the valve stem should be examined, as it may be of advantage to plane off or line under the foot of the link support which might correct the length of both rods, or at least only one of these would need to be changed.
2. The difference between the two positions of the valve on the forward and back centers is the lead and lap doubled and it cannot be changed except by changing the leverage relations of the combination lever.
3. A given lead determines the lap or a given lap determines the lead, and it must be divided for both ends as desired by lengthening or shortening the valve spindle.
4. Within certain limits, this adjustment may be made by shortening or lengthening the radius bar but it is desirable to keep the length of this bar equal to the radius of the link in order to meet the requirements of the first condition.
5. The lead may be increased by reducing the lap, and the cut-off point will then be slightly advanced. Increasing the lap introduces the opposite effect on the cut-off. With good judgment, these qualities may be varied to offset other irregularities inherent in transforming rotary into lineal motion.



6. Slight variations may be made in the cut-off points as covered by the preceding paragraph but an independent adjustment cannot be made except by shifting the location of the suspension point which is preferably determined by a model.

**Comparison between Stephenson and Walschaert Gears.** A comparison of the Stephenson and Walschaert valve gears shows that steam distribution in former would not differ to a very great extent from that in the latter save in that produced by the constant lead.

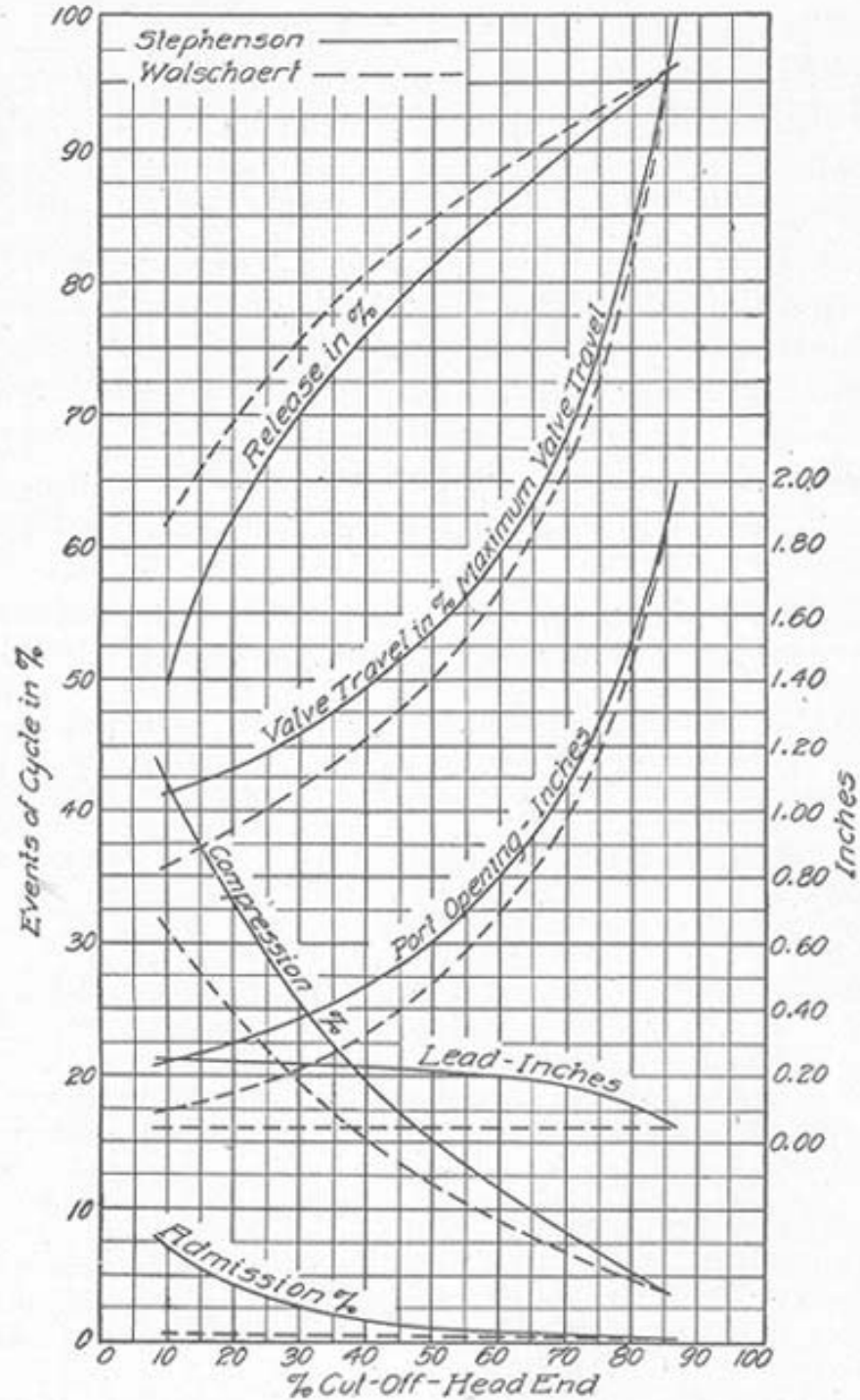

Fig. 69-a. Curves Showing Events for Head End of Forward Motion for Stephenson and Walschaert Gears.

The factors in favor of the Walschaert gear are largely mechanical ones which may be designated as *easily accessible parts* and a *less amount of care in maintenance*. The parts making up the Walschaert valve gear are outside of the frames where they can be easily reached in case of breakdowns and necessary repairs. Another advantage accruing from this fact is that the space between the frames is left open permitting bracing, which protects and strengthens the frames. This is not possible when the Stephenson gear is used. The smaller number of moving parts, hardened pins, and accessible bearings in the Walschaert gear result in fewer and less expensive repairs.

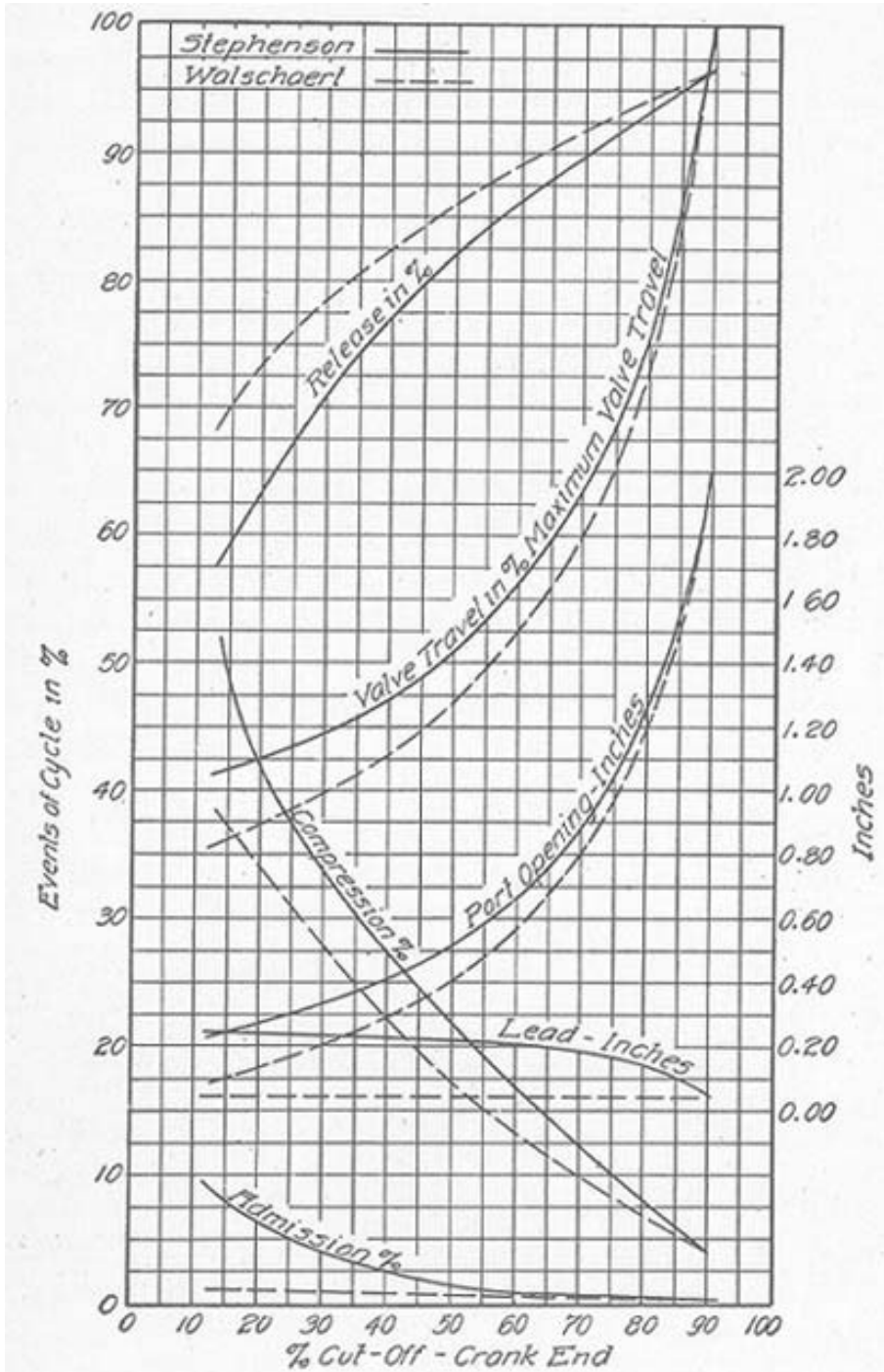

Fig. 69-b. Curves Showing Events for Crank End of Forward Motion for Stephenson and Walschaert Gears.



A study of the action of a valve on a given locomotive, when operated by means of a Walschaert gear and also a Stephenson gear, gave the results shown graphically in [Figs. 69-a](#) and [69-b](#). The results were taken from Zeuner diagrams, drawn to represent the steam distribution given by each gear. The general dimensions of the two gears, taken from designs prepared for use on a given locomotive are shown in Table VIII.

The conditions for both the head end and crank end of the forward motion, in both Stephenson and Walschaert gears are represented in [Figs. 69-a](#) and [69-b](#). Each event of the cycle-valve travel, port opening, and lead-is plotted with reference to the cut-off. As can be seen, the Walschaert gear gives for all cut-off positions a later admission, later release, later compression, less lead, less port opening, and less valve travel than does the Stephenson gear. With the exception perhaps of lead, the differences are negligibly small for all cut-off positions beyond 50 per cent. With cut-off positions less than 50 per cent, however, these differences increase quite rapidly.

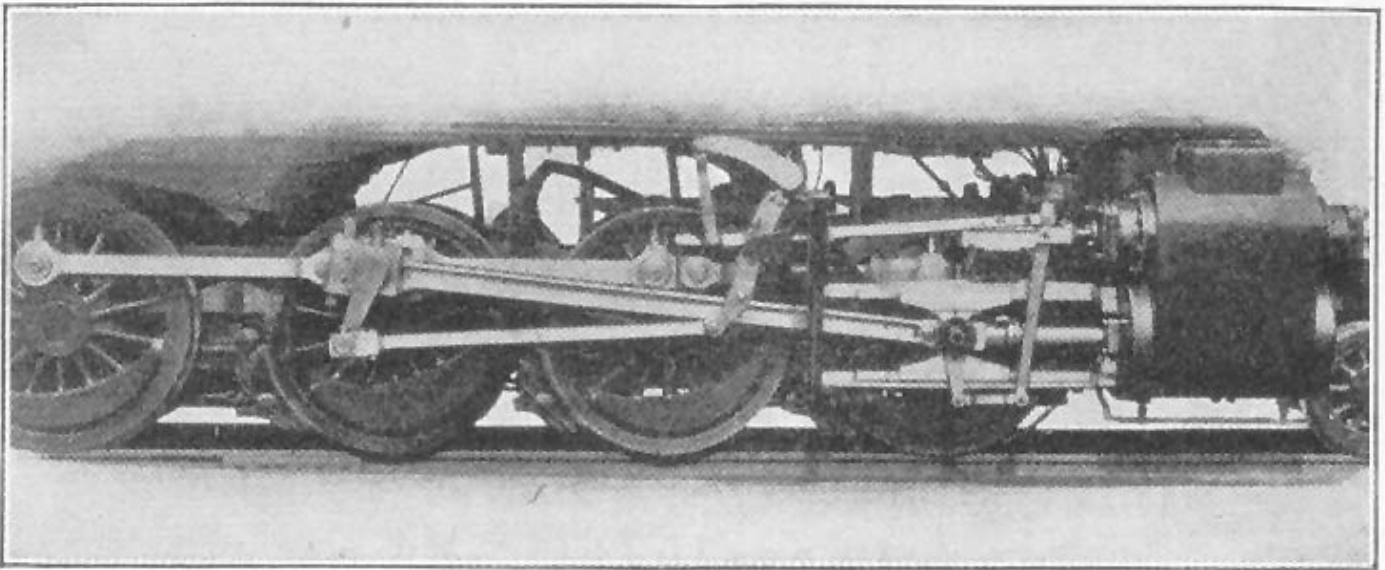

Fig. 69-c. Walschaert Valve Gear Mounted on Consolidated Freight Locomotive.

The Walschaert gear is applied to a locomotive in several ways, each having its own advantages. The method illustrated in [Fig. 69-c](#) gives the student a general idea how the scheme is worked out and applied in connection with a consolidative freight locomotive.

**TABLE VIII**

**Comparative Dimensions of Stephenson and Walschaert Gears**

	Stephenson Gear	Walschaert Gear
Type of valve	D-Slide	D-Slide
Steam lap in inches, H.E.	1.0	1.0
Steam lap in inches, C.E.	1.0	1.0
Exhaust lap in inches, H.E.	0	0
Exhaust lap in inches, C.E.	0	0
Lead at full gear in inches	3/64	3/64
Lead at mid gear in inches	1/4	3/64
Width of port in inches	1	1
Maximum valve travel in inches	6	6
Stroke of piston in inches	24	24
Length of connecting rod in inches	96	96
Radius of link arc in inches	60	
Length of radius rod in inches		46

**Valves.** Until recent years the valve ordinarily used on locomotives was the *plain slide valve*, partially balanced. In the plain slide valve the full steam chest pressure is exerted over the whole of the back surface of the valve. The balancing of a valve consists in removing a portion of this pressure, thus decreasing the frictional resistance of the valve on its seat.

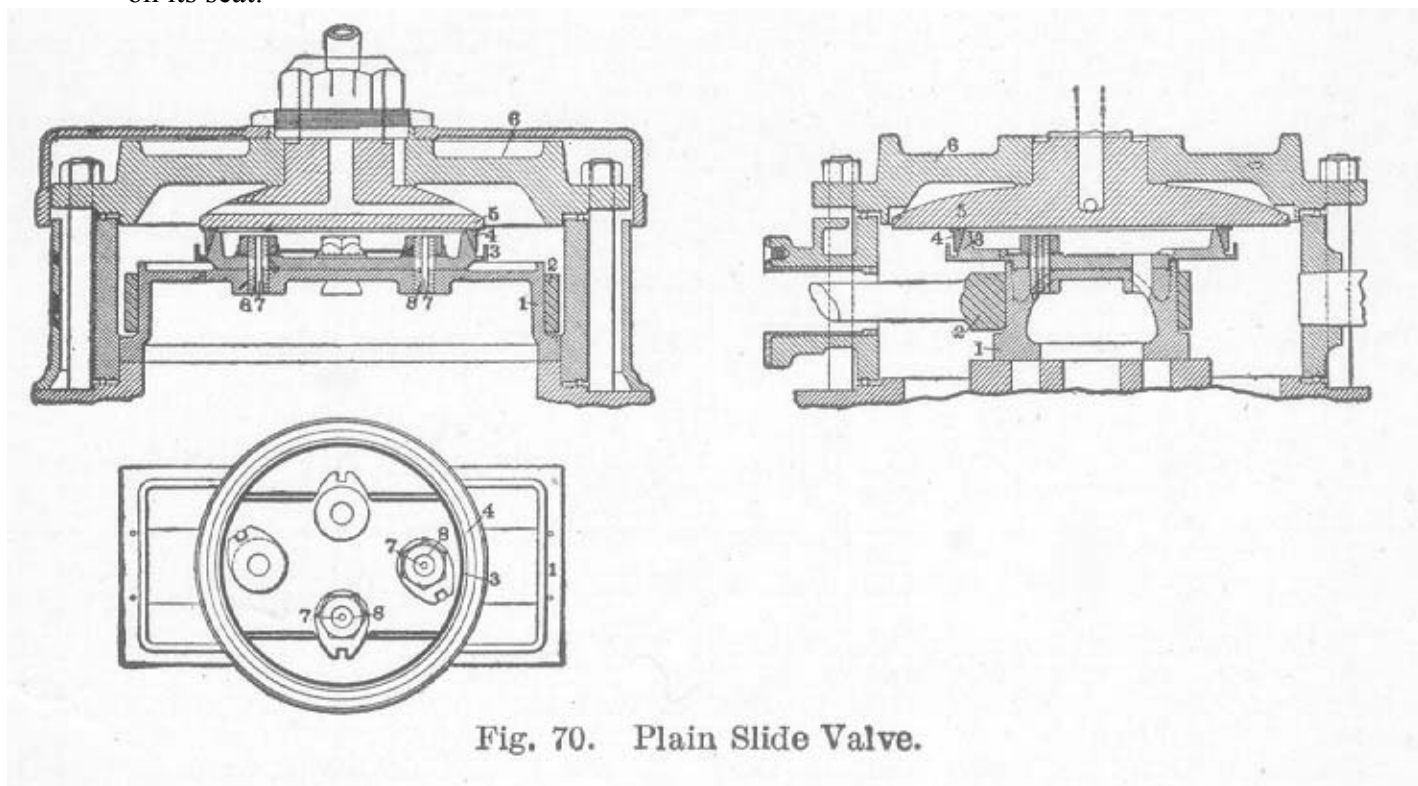

**Fig. 70. Plain Slide Valve.**

The percentage of this pressure that is removed, or the *amount of balance*, varies from 45 to 90 per cent of the total face of the valve, and the average in practice is about 65 per cent. In the valve shown in [Fig. 70](#), the balance is 69 per cent. The pinch of the packing ring on the cone slightly increases the pressure of the valve on its seat. In [Fig. 70](#), the valve, 1, is of the ordinary D type driven by the yoke, 2, which is forged as a part of the valve stem. To the back of the valve is bolted a circular plate, 3, having a cone turned thereon. On this cone is fitted a loose ring, 4, the inner face of which is beveled to the same degree as the taper of the cone. The ring is cut at one point and is, therefore, flexible. The open space at the cut in the ring is covered by an L-shaped clip which is placed on the outside and fastened to one end of the ring, the other end of the ring remaining free. This L-shaped clip reaches to the top of the ring at the outside and under the ring at the bottom to the taper of the cone. It thus forms joints just the same as the ring itself, making a continuous yet flexible ring. The ring is made of cast iron and is bored smaller than the diameter required for the working position. Therefore, before the steam chest cover is placed in position, it sets slightly higher on the cone than it does when at work. To the inner side of the steam chest cover, 6, is bolted a back plate, 5, against which the ring, 4, forms a steam tight joint. Owing to the raised position of the ring when first put on, the placing of the cover and the back plate forces the ring down over the cone. This expands the former to a larger diameter and it is thus held in its expanded position under tension with the tendency to maintain the joint between itself and the wearing plate.

Another method employed in balancing a slide valve is to cut grooves in the top of the valve which extend across the four sides of the valve. In these grooves are placed carefully fitted narrow strips which rest on small springs which keep the strips pressed up against a pressure plate, thus keeping the steam away from a large part of the valve.

In order to provide for any leakage which may occur past the ring and to prevent an accumulation of pressure within the same, the holes, 7, are drilled through the studs, 8. These drain the space and accomplish the desired result.

A relief valve is placed on the steam chest. This is a check valve opening inward and serves to equalize the pressure in the two ends of the cylinder when the locomotive is coasting, thus preventing unequal pressure at either end.

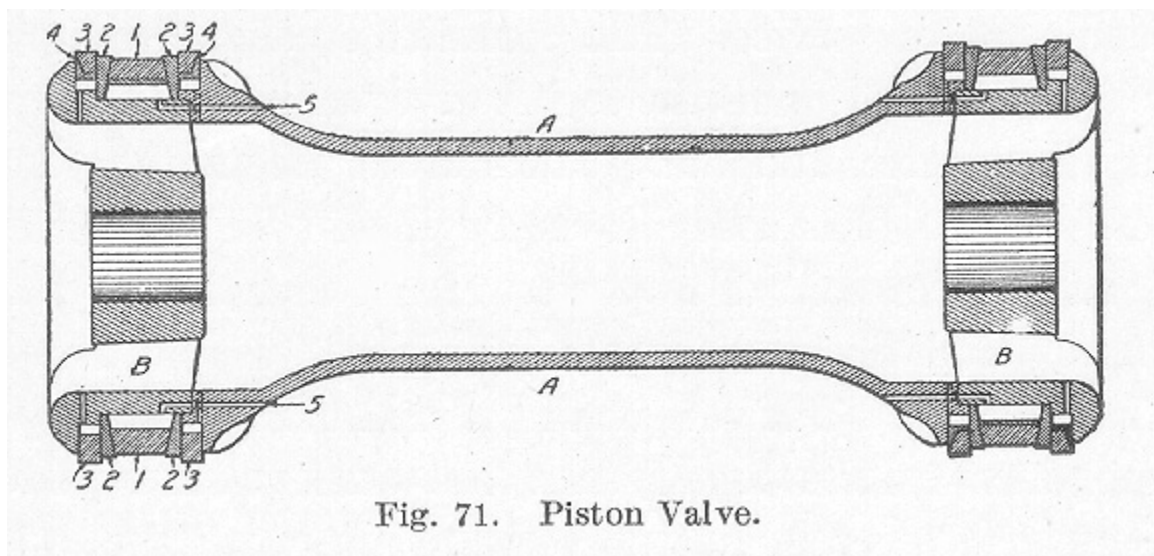

Fig. 71. Piston Valve.

Another form of valve which is now being extensively used is the piston valve, illustrated in [Fig. 71](#). In this valve, the steam is admitted at the center in the space *A* and is exhausted at the ends. Such valves are self-balanced since they are entirely surrounded by steam. Another form of piston valve is constructed with a passage extending through its entire length which connects with a live steam passage. In this type of valve, steam is admitted at the ends of the valve at *B*, and when exhausted passes around the circular part *A* to the exhaust cavity. In piston valves, it only remains to pack the ends to prevent steam leaks. This is done by using packing rings. [In Fig. 71](#), the packing consists of seven pieces at each end, numbered 1, 2, 3, and 4. Numbers 3 and 4 are the packing rings proper. They consist of the split rings, 3, and the L-shaped covering piece, 4, for the split in No. 3. The rings, 2, are solid and serve merely as surfaces against which the rings, 3, have a bearing. The wedge ring, 1, is split and can expand. The rings, 3, are turned larger than the diameter of the steam chest and are sprung into position. Small holes, 5, are drilled from the steam space *A* to a point beneath the wedge ring, 1. When the throttle valve is opened, steam enters the holes, 5, forcing the wedge, 1, out between the rings, 2. It locks the packing ring, 3, firmly between the ring, 2, and the lip of the valve. This prevents rattling and working loose of the rings, making the valve practically steam-tight.

A form of packing largely used and which is much simpler than the above, consists of ordinary snap rings inserted into annular grooves cut around the heads of the valves.

**Valve Friction.** Of the many different parts of a locomotive which have been studied from the scientific standpoint, few parts have been given more attention than the main steam valve. When the valves were small and steam pressures were not high, the force necessary to move the valve when in operation was not very great. With the pressures employed today and the sizes of steam ports found on our modern locomotives, the reduction of valve friction becomes a very important matter. From an examination of [Figs. 70](#) and [71](#), it is an easy matter to see that the more completely a valve is balanced, the less work will be required to move it back and forth when in service.

*Valve Tests to Determine Friction.* The question was considered such an important one that the Master Mechanics' Association appointed a committee to investigate different types of valves under conditions of service. The committee conducted its experimental work, in 1896, upon the locomotive testing plant at Purdue University, Lafayette, Indiana. The Purdue locomotive, known as Schenectady No. 1, was used, having cylinders 17 inches in diameter by 24 inches stroke. The ports were 16 inches long, the steam port being 1-1/4 and the exhaust port 2-1/2 inches wide. The bridges were 1-1/8 inches wide. The valve had a maximum travel of 5-1/2 inches, steam lap, 3/4-inch, exhaust lap, 1/32-inch, and was set with a 1/16-inch lead, with the reverse lever in its full forward position, and a 7/32-inch negative lead, with the reserve lever in its full backward position.

Four different slide valves were tested as follows: unbalanced D-valve, Richardson balanced valve, American balanced valve with single balance ring, and American balanced valve with two balance rings. A fluid dynamometer was placed in position between the valve stem and rocker arm in such a manner as to measure the force necessary to overcome the friction of the valve when operated under different conditions. The valves weighed 78, 85-1/2, 79-1/4, and 84 pounds, respectively. The weight of the dynamometer was 105 pounds and that of the valve yoke 37 pounds. The Richardson valve had 56 per cent of the area of the valve face balanced by the use of flat strips held

against the balance plate by springs. The American valves had 61-1/2 ,and 66 per cent of their areas balanced by using single and double balancing rings, respectively.

The power required to operate the different valves was determined by means of the fluid dynamometer to which was attached a steam engine indicator. The arrangement was such that pressure diagrams could be taken in which the length corresponded to the stroke of the valve and the height to the pressure of the fluid on the piston of the dynamometer. Tests were conducted at different cut-offs and speeds. A few of the results secured are presented in Tables IX and X.

**TABLE IX**

**Valve Tests Showing Mean Pull in Pounds for Different Valves**

(Steam Chest Pressure, 100 Pounds per Square Inch)

Cut-Off in Inches	22			9-1/2		
	10	20	40	10	20	40
<b>Richardson</b>	382	396	772	361	442	468
<b>American single</b>	.....	522	872	394	535	591
<b>American double</b>	.....	488	762	412	500	568
<b>Unbalanced</b>	1118	1062	1207	1322	1240	1180

**TABLE X**

**Valve Tests Showing Per Cent of I.H.P. of One Cylinder Required to Move Valve**

Cut-Off in Inches	22			9-1/2		
	10	20	40	10	20	40
<b>Richardson</b>	0.43	0.49	1.54	0.32	0.34	0.61
<b>American single</b>	0.48	0.65	1.91	0.27	0.40	0.67
<b>American double</b>	.....	0.61	1.66	0.27	0.45	0.63
<b>Unbalanced</b>	1.20	1.30	2.42	0.82	.....	1.62

The committee in their report to the society stated that the friction or resistance of unbalanced valves was about twice as great as that of balanced valves and recommended that the area of balance should equal the area of the exhaust port plus the area of the two bridges plus the area of one steam port. As a result of the work done by the committee and by some of the railway companies, it soon became evident that the D-valve for locomotive work was very inefficient. For this reason, in recent years the piston type of valve, which in itself is balanced, is being almost universally used.



## RUNNING GEAR

The running gear of a locomotive is composed of the following important parts: Wheels, axles, rods, pistons, and the frames which form a connection between these parts.

**Wheels.** The driving wheels have a cast-iron or steel center protected by a steel tire. Until about 1896, cast iron was universally employed for wheel centers and is yet used for the smaller engines.

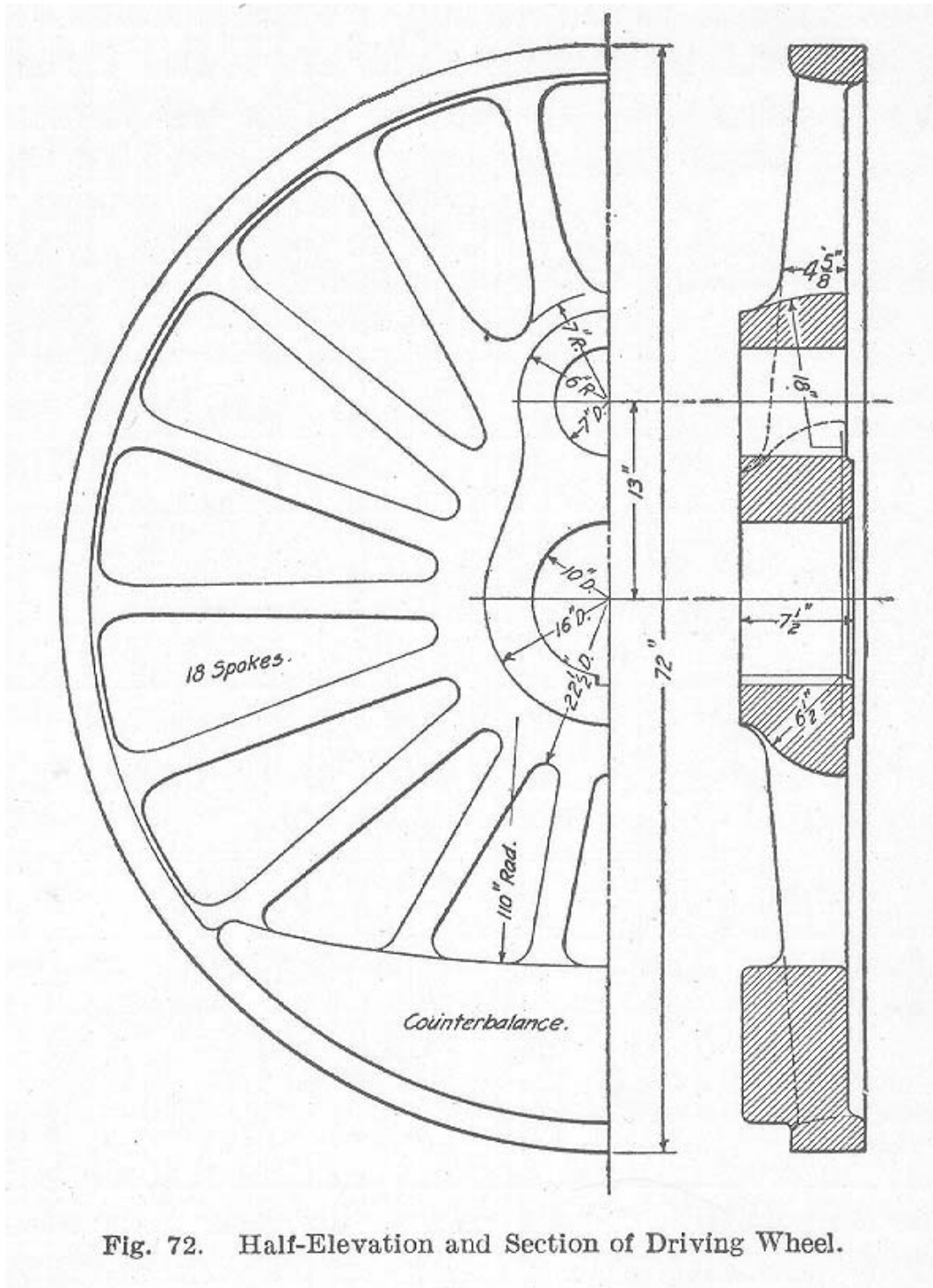



For engines having large cylinders, where a saving of weight is important, cast steel is now used makes possible a considerably lighter construction. Such a wheel is illustrated in [Fig. 72](#). The universal method of fastening on the tire is to bore it out a trifle smaller than the diameter to which the center is turned, then expand it by heating and after slipping it over the center allow it to contract by cooling. The shrinkage commonly used is 1/80 of an inch for each foot diameter of wheel center for all centers of cast iron or cast steel less than 66 inches in diameter. For centers more than 66 inches in diameter, 1/60 of an inch for each foot diameter is allowed for shrinkage. This gives the following shrinkages:

**TABLE XI**

**Shrinkage Allowance**

Diameter of Center	Shrinkage	Bored Diameter of Tire
56	.058	55.94
58	.060	57.94
60	.063	59.93

The American Master Mechanics' Association recommends the following concerning wheel centers:

In order to properly support the rim and to resist the tire shrinking, the spokes should be placed from 12 to 13 inches apart from center to center, measured on the outer circumference of the wheel center. The number of spokes should equal the diameter of center expressed in inches divided by 4. If the remainder is <sup>^</sup> or over, one additional spoke should be used. The exact spacing of the spokes according to this rule would be

$$3.1416 \times 4 = 12.56 \text{ inches}$$

Wheel centers arranged in this manner would have the following number of spokes:

**TABLE XII**

**Spoke Data - General**

Diameter of Centers	Number of Spokes	Diameter of Centers	Number of Spokes
38	10	72	18
44	11	74	19
50	13	76	19
56	14	78	19
62	16	80	20
66	17		

Among pattern makers and foundry men, there is an impression that an uneven number of spokes should be used so as to avoid getting two spokes directly opposite each other in a straight line. The following table has been made up on this basis:

**TABLE XIII****Spoke Data - Foundry Rule**

<b>Diameter of Center</b>	<b>Number of Spokes</b>	<b>Pitch</b>
44	11	12.5
48	11	13.6
50	13	12.6
54	13	13.0
56	13	13.5
60	15	12.6
62	15	13.0
66	15	13.8
68	17	12.5
70	17	12.9
72	17	13.3
74	17	13.6
76	19	12.6
78	19	12.9

The spokes at the crank hub should be located so that the hub will lie between two of the spokes and thus avoid a short spoke directly in line with the crank pin hub.

Cast steel driving wheel centers should be preferably cast with the rims and uncut shrunk slots omitted whenever steel foundries will guarantee satisfactory castings. For wheel centers 60 inches in diameter and when the total weight of the engine will permit, the rims should preferably be cast solid without cores so as to obtain the maximum section and have full bearing surface for the tires.

It is difficult to get sufficient counterbalance in centers smaller than 60 inches in diameter so that it will be found very desirable to core out the rims to obtain the maximum lightness on the side next to the crank pin and in some cases on the counterbalance side in order to fill in with lead where necessary.

The American Master Mechanics' Association recommends a rim section as shown in [Fig. 73](#) for wheel centers without retaining rings. The tire is secured from having the center forced through it by a lip on the outside 3/8 inch in width and about 1/8 inch in height, the tire being left rough at this point. The height of the lip, therefore, depends upon the amount of finishing left on the interior of the tire. Accurate measurements of tires after they have been in service for some time, especially when less than 2-1/2 inches in thickness, show that a rolling out or stretching of the tire occurs, and for reasonably heavy centers, these figures will account more for loose tires than any permanent set in the driving wheel center.

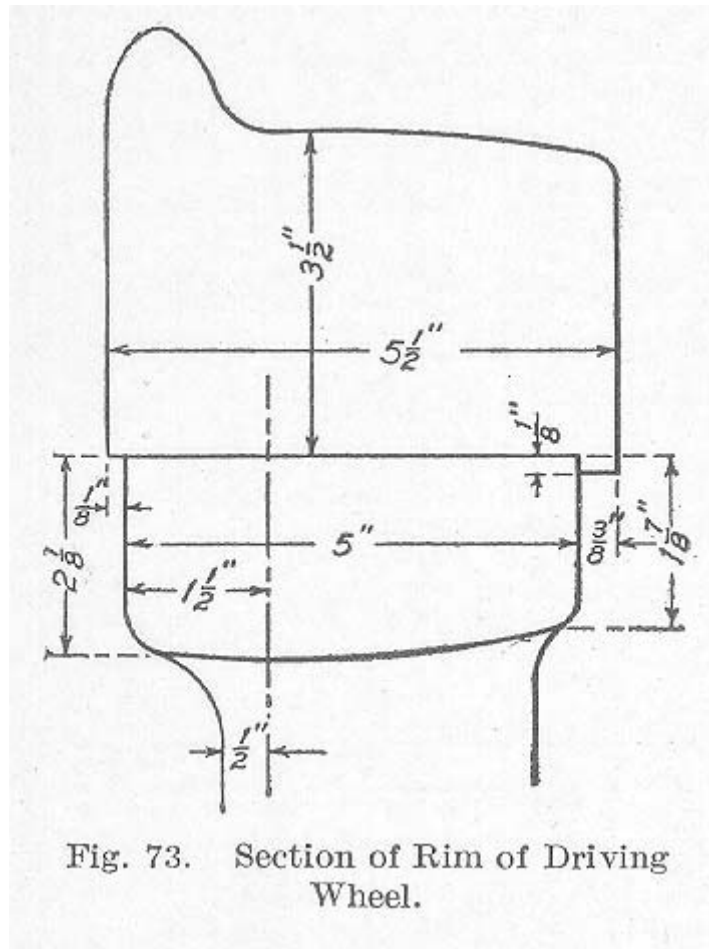

Fig. 73. Section of Rim of Driving Wheel.

*Counterbalance.* A study of the construction of the driving wheel brings up the question of counterbalance since it is made a part of the wheel center. The counterbalance, [Fig. 72](#), is the weight or mass of metal placed in the driving wheel opposite the crank to balance the revolving and reciprocating weights.

The revolving weights to be balanced are the crank pin complete, the back end of the main rod or connecting rod, and each end of each side rod complete. The sum of the weights so found which are attached to each crank pin is the revolving weight for that pin.

The reciprocating weights to be balanced consist of the weight of the piston complete with packing rings, piston rod, crosshead complete, and the front end of the main rod complete. The weight of the rod should be obtained by weighing in a horizontal position after having been placed on centers.

The revolving weights can be counterbalanced by weights attached to the wheel to which they belong, while the reciprocating weights can only be balanced in one direction by adding weights to the driving wheels as all weights added after the revolving parts are balanced overbalance the wheel vertically exactly to the same extent that they tend to balance the reciprocating parts horizontally. This overbalance exerts a sudden pressure or hammer blow upon the rail directly proportional to its weight and to the square of its velocity. At high speeds, this pressure, which is added to the weight of the driver on the rail, may become great enough to injure the track and bridges.

The best form of counterbalance is that of a crescent shape which has its center of gravity the farthest distance possible from the center of the axle. The counterbalance should be placed opposite the crank pin as close to the rods as proper clearance will allow. The clearance should be not less than 3/4 inch. No deficiency of weight in any wheel should be transferred to another. All counter balance blocks should be cast solid. When it is impossible to obtain a correct balance for solid blocks, they may be cored out and filled with lead, which will increase their weight. In all such cases the cavities must be as smooth as possible. Holes should be drilled through the inside face of the wheel to facilitate the removal of the core sand.

In counterbalancing a locomotive, the following fundamental principles should be kept in mind:

1. The weight of the reciprocating parts, which is left unbalanced, should be as great as possible, consistent with a good riding and smooth working engine.
2. The unbalanced weight of the reciprocating parts of all engines for similar service should be proportional to the total weight of the engine in working order.
3. The total pressure of the wheel upon the rail at maximum speed when the counterbalance is down, should not exceed an amount dependent upon the construction of bridges, weight of rail, etc.
4. When the counterbalance is on the upper part of the wheel, the centrifugal force should never be sufficient to lift the wheel from the rail.

The following rules have been generally accepted for the counterbalancing of locomotive drive wheels:

1. Divide the total weight of the engine by 400, subtract the quotient from the weight of the reciprocating parts on one side including the front end of the main rod.
2. Distribute the remainder equally among all driving wheels on one side, adding to it the sum of the weights of the revolving parts for each wheel on that side. The sum for each wheel if placed at a distance from the driving wheel center, equal to the length of the crank, or at a proportionately less weight if at a greater distance, will be the counterbalance weight required.

The method of adjusting the counterbalance in the shop is as follows: After the wheels have been mounted on the axle and the crank pins put in place, the wheels are placed upon trestles as illustrated in [Fig. 74](#). These trestles are provided with perfectly level straight edges upon which the journals rest. A weight pan is suspended from the crank pin as shown. In this pan is placed weight enough to just balance the wheels in such a position that a horizontal line will pass through the center of the axle and crank pin and counterbalance on one wheel, and a vertical line will pass through the axle and crank pin centers of the other side, the crank being above. The amount of weight thus applied, including the pan and the wire by which it is suspended, gives the equivalent counterbalance at crank radius available for balancing the parts. This weight found must not exceed that found to be necessary by the formula. Should the counterbalance be left with extra thickness, the extra weight can be turned off with little trouble after the trial described has been completed. This process should be repeated for the opposite side.

The weight of the reciprocating parts should be kept as low as possible, consistent with good design. Locomotives with rods disconnected and removed should not be handled in

trains running at high rates of speed because of the danger arising from damage to the track and bridges, due to the hammer blow.

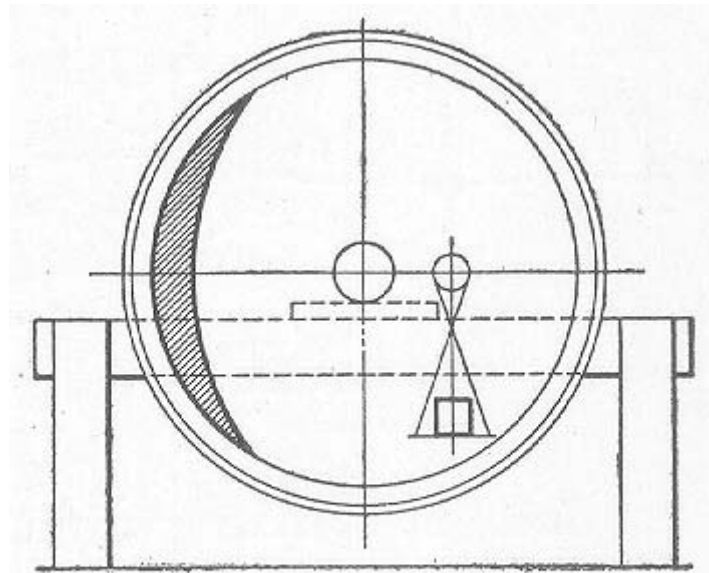

Fig. 74. Diagram Showing Method of Counterbalancing Driving Wheels.

**Axles.** Driving and engine truck axles are made of open hearth steel, having a tensile strength not less than 80,000 pounds per square inch. Modern practice requires that axles conform to the tests and standards adopted by the American Railway Master Mechanics' Association and the American Society for Testing Materials. One axle is required to be tested from each heat. The test piece may be taken from the end of any axle with a hollow drill, the hole made by the drill to be not more than 2 inches in diameter nor more than 4½ inches deep. This test piece is to be subjected to the physical and chemical tests provided for in the code of the societies mentioned above.

All forgings must be free from seams, pipes, and other defects, and must conform to the drawings furnished by the company. The forgings, when specified, must be weighed, turned with a flat nosed tool, and cut to exact length and centered with 60 degree centers. All forgings not meeting the above requirements or which are found to be defective in machining and which cannot stand the physical chemical tests will be rejected at the expense of the manufacturers.

The above requirements, while intended for driving axles, apply in a general way to engine truck axles. Axles are forged from steel billets, of the proper size to conform to the size of the axles as required for standard gauge work.

In accordance with the foregoing, Table XIV is presented, which gives the sizes and the weights of billets for standard driving and engine truck axles.

**TABLE XIV****Forged Steel Billets**

(Standard Sizes)

DRIVING AXLES			ENGINE TRUCK AXLES		
Diameter of Journal, Inches	Size of Billet, Inches	Weight of Billet, Pounds	Diameter of Journal, Inches	Size of Billet, Inches	Weight of Billet, Pounds
8	10 x 10	2590	5	7 x 7	970
8½	11 x 11	2900	5½	7 x 7	1170
9	11 x 11	3220	6	8 x 8	1380
9½	12 x 12	3570	6½	8 x 8	1600
10	12 x 12	3930	7	9 x 9	1830

After the axles are received in the rough state, the journals and wheel fits are turned up, in the shop, to the proper dimensions. In turning up the wheel fits, they are left slightly larger in diameter than the diameter of the axle opening in the wheel center. The wheel center is then forced on the axle by means of hydraulic pressure. Table XV gives the pressure employed in forcing-in engine truck and driving axles.

**TABLE XV****Hydraulic Pressures Used in Mounting Axles**

DRIVING AXLES			ENGINE TRUCK AXLES		
Diameter of Fit in Inches	Pressure Employed in Tons		Diameter of Fit in Inches	Pressure Employed in Tons	
	Cast-Iron Center	Cast-Steel Center		Cast-Iron Center	Cast-Steel Center
7 - 7½	70 - 75	112 - 120	4 - 4½	25 - 30	37 - 45
7½ - 8	75 - 80	120 - 128	4½ - 5	30 - 35	45-52
8 - 8½	80 - 85	128 - 136	5 - 5½	35 - 40	52 - 60
8½ - 9	85 - 90	136 - 144	5½ - 6	40 - 45	60 - 67
9 - 9½	90 - 95	144 - 152	6 - 6½	45 - 50	67 - 75
9½ - 10	95 - 100	152 - 160	6½ - 7	50 - 55	75 - 82
10 - 10½	100 - 105	160 - 168	7 - 7½	55 - 60	82 - 90
10½ - 11	105 - 110	168 - 176			

**Crank-Pins.** All specifications and test requirements mentioned under the discussion of driving and engine truck axles are applicable to crank-pins. Crank-pins are received by railroad companies in the rough forging and must, therefore, be turned to fit the wheel



boss. They are forced in by hydraulic pressure, the pressures commonly employed being given in Table XVI.

**TABLE XVI**

**Hydraulic Pressures Used in Mounting Crank-Pins**

Diameter of Fit in Inches	Pressure Employed in Tons	
	Cast-Iron Center	Cast-Steel Center
3 - 3½	15 - 20	24 - 32
3½ - 4	20 - 25	32 - 40
4 - 4½	25 - 30	40 - 48
4½ - 5	30 - 35	48 - 56
5 - 5½	35 - 40	56 - 64
5½ - 6	40 - 45	64 - 72
6 - 6½	45 - 50	72 - 80
6½ - 7	50 - 55	80 - 88

**Locomotive Frames.** Among other details of importance in the construction of a locomotive, none is more important than the frame. The frame is the supporting element and the tie bar that connects all the various moving and fixed parts. Its present form and proportions are due most largely to development rather than to pure design. It would be extremely difficult to analyze all the various forces to which the frames are subjected. There are two principal classes of locomotive frames, namely, the *single front rail* and the *double front rail*. The single front rail is illustrated in [Fig. 75](#).

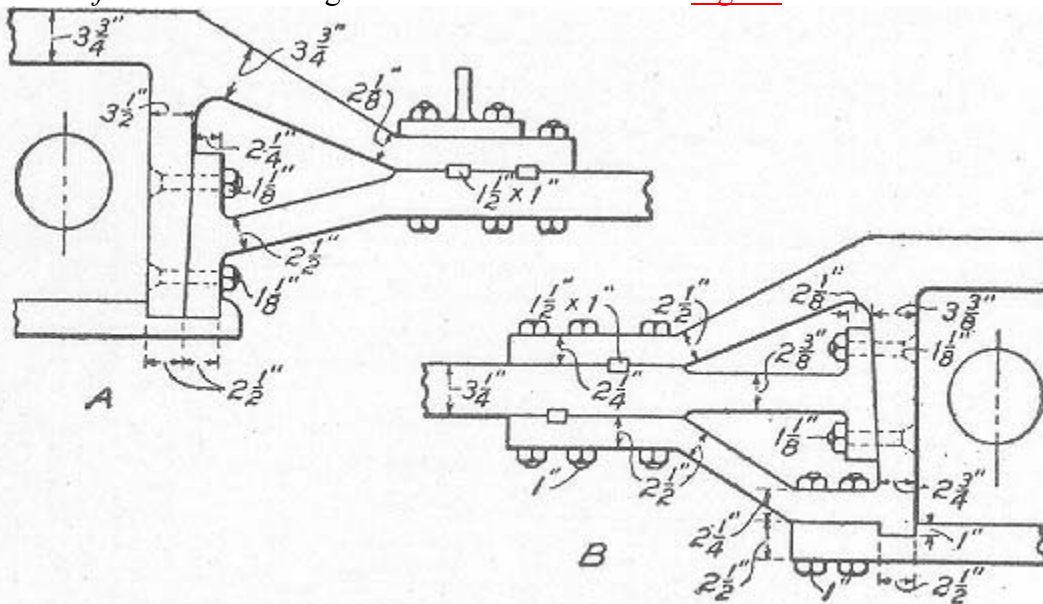

**Fig. 75. Single Front Rail Locomotive Frames.**

At first the joint between the main frame and the front rail was made as shown at *A* in [Fig. 75](#). The rear end of the front rail was bent downward with a T-foot formed thereon

by means of which it was connected to the main frame. The top member of the main frame was bent down and extended forward and connected to the front rail by means of bolts and keys. The T-head was fastened to the pedestal by two countersunk bolts. As locomotives grew in size, much trouble was experienced due to the countersunk bolts becoming loose or breaking. To overcome this difficulty, the form of joint shown in *B*, [Fig. 75](#), was developed. Here the pedestal had a member welded to it which extended forward and upward to meet the front rail. The top member extended outward and downward as before. The front rail fitted between these two members and had a foot which rested against the pedestal. This latter form was used for many years, being changed in details considerably but retaining the same general arrangement. These forms of single bar frames continued to be used for many years and are employed at the present time for light locomotives. When the heavier types of locomotives, such as the Consolidation made their advent, it became necessary to improve the design of the frame. To meet this necessity, the double front rail frame was developed. [Fig. 76](#) illustrates one of the earlier forms of this frame.

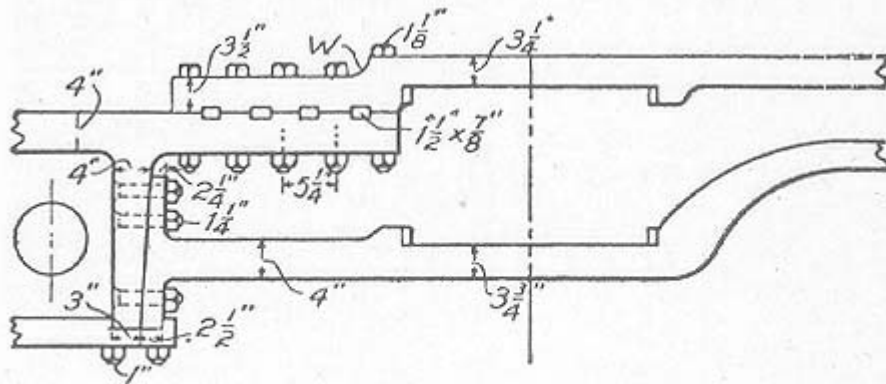

Fig. 76. Early Form of Double Front Rail Frame.

The top rail was placed upon and securely bolted to the top bar of the main frame and the lower front rail was fastened to the pedestal by means of a T-foot with countersunk bolts. The same difficulty was experienced with this design as with the first form of the single front rail type, namely, the breaking of the bolts fastening the lower bar to the pedestal. This led to experiments being tried which resulted in many stages of advancement until a heavy and serviceable design was developed, as shown in [Fig. 77](#).

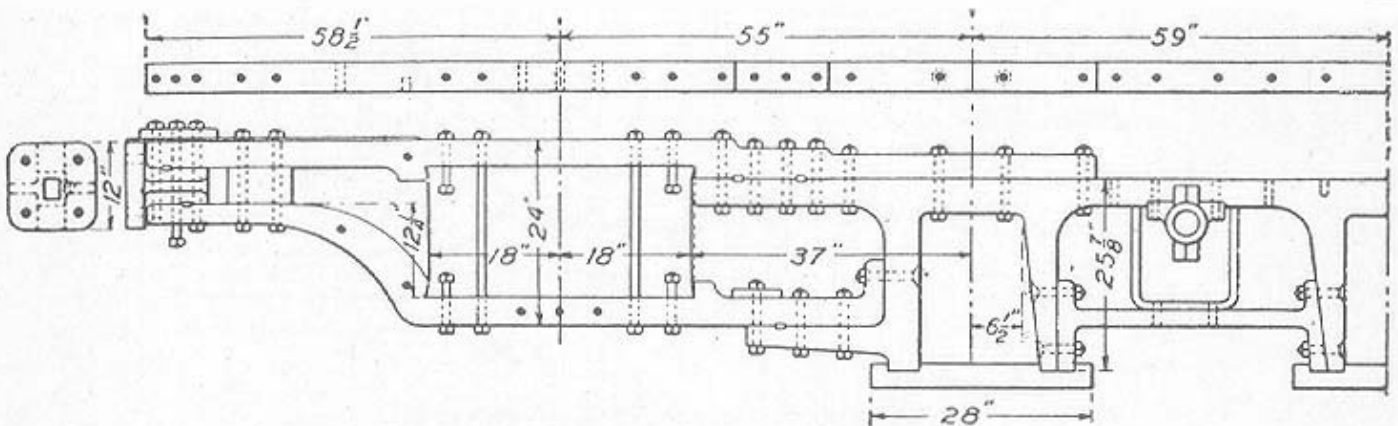

Fig. 77. Heavy Form of Double Front Rail Frame.

In this design the pedestal has a bar welded to it on which the lower front rail rests and to which it is connected by means of bolts and keys. The top front rail rests on top of the top main frame and extends back beyond the pedestal, thus giving room for the use of more bolts. The design shown in [Fig. 77](#) is the one largely used on all heavy locomotives, it being slightly changed in detail for the various types. In addition to the two general types of bar locomotive frames which are made of wrought iron or mild steel, a number of cast-steel frames are being used. The general make-up of the cast-steel frame does not differ materially from that of the wrought iron except in the cross-section of the bars. The bar frame is rectangular or square in cross-section whereas the sections of cast-steel frames are usually made in the form of an **I**.

**Cylinder and Saddle.** The cylinder and saddle for a simple locomotive, illustrated in [Fig. 78](#), are constructed of a good quality of cast iron. The casting is usually made in two equal parts but it is not uncommon to find the saddle formed of one casting, each cylinder being bolted to it, making three castings in all. [Fig. 78](#) illustrates the two-piece casting commonly used. The two castings are interchangeable and are securely fastened together by bolts of about  $1\frac{1}{4}$  inches in diameter. The part of the casting known as the *saddle* is the curved portion *A*, which fits the curved surface of the smoke-box of the boiler. This curved surface after being carefully chipped and fitted to the smoke-box is then securely fastened to it by means of bolts. This connection must not only be made very securely but air tight as well, in order that the vacuum in the smoke-box may be maintained. In the cross-sectional view, the live steam passage *B* and exhaust passage *C* are shown. The steam enters the passage *B* from the branch pipe and travels to the steam chest from which it is admitted into the cylinder through the steam ports *F*. After having completed its work in the cylinder, it passes through the exhaust port *G* into the exhaust passage *C* to the stack. The cylinder casting is fastened to the frames of the locomotive as well as to the boiler. *D* and *E* show the connection of the saddle casting to the frame. In this case a frame having a double front rail is used, each bar being securely bolted to the casting.

**The Piston and Rods.** The pistons of locomotives vary greatly in details of construction but the general idea is the same in all cases. Since the pistons receive all the power the locomotive delivers, they must be strongly constructed and steam tight. All pistons consist of a metal disk mounted on a piston rod which has grooves on the outer edges for properly holding the packing rings. The pistons are commonly made of cast iron, but where great strength is required, steel is now being used. [Fig. 79](#) illustrates the present tendency in design. The cylindrical plate is made of cast-steel and the packing rings, two in number, are made of cast iron. The packing rings are of the snap ring type and are free to move in the grooves.

As can be seen, the rim is widened near the bottom in order to provide a greater wearing surface. [Fig. 79](#) also clearly shows the method used in fastening the piston to the piston rod. The piston rod is made of steel and has a tapered end which fits into the cross-head where it is secured by a tapered key. The crosshead fit is made accurate by careful grinding. The crosshead key should likewise be carefully fitted.

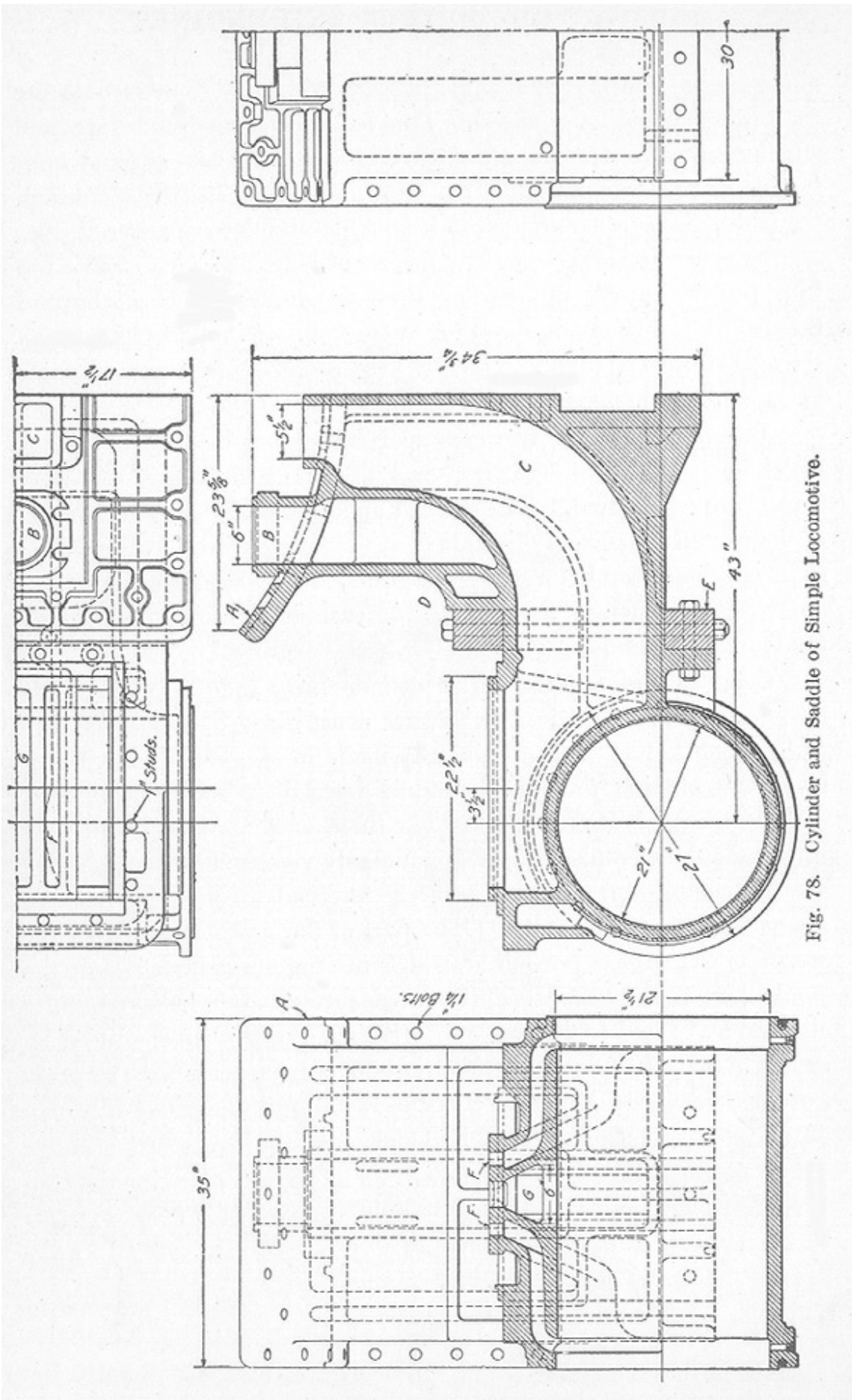

Fig. 78. Cylinder and Saddle of Simple Locomotive.



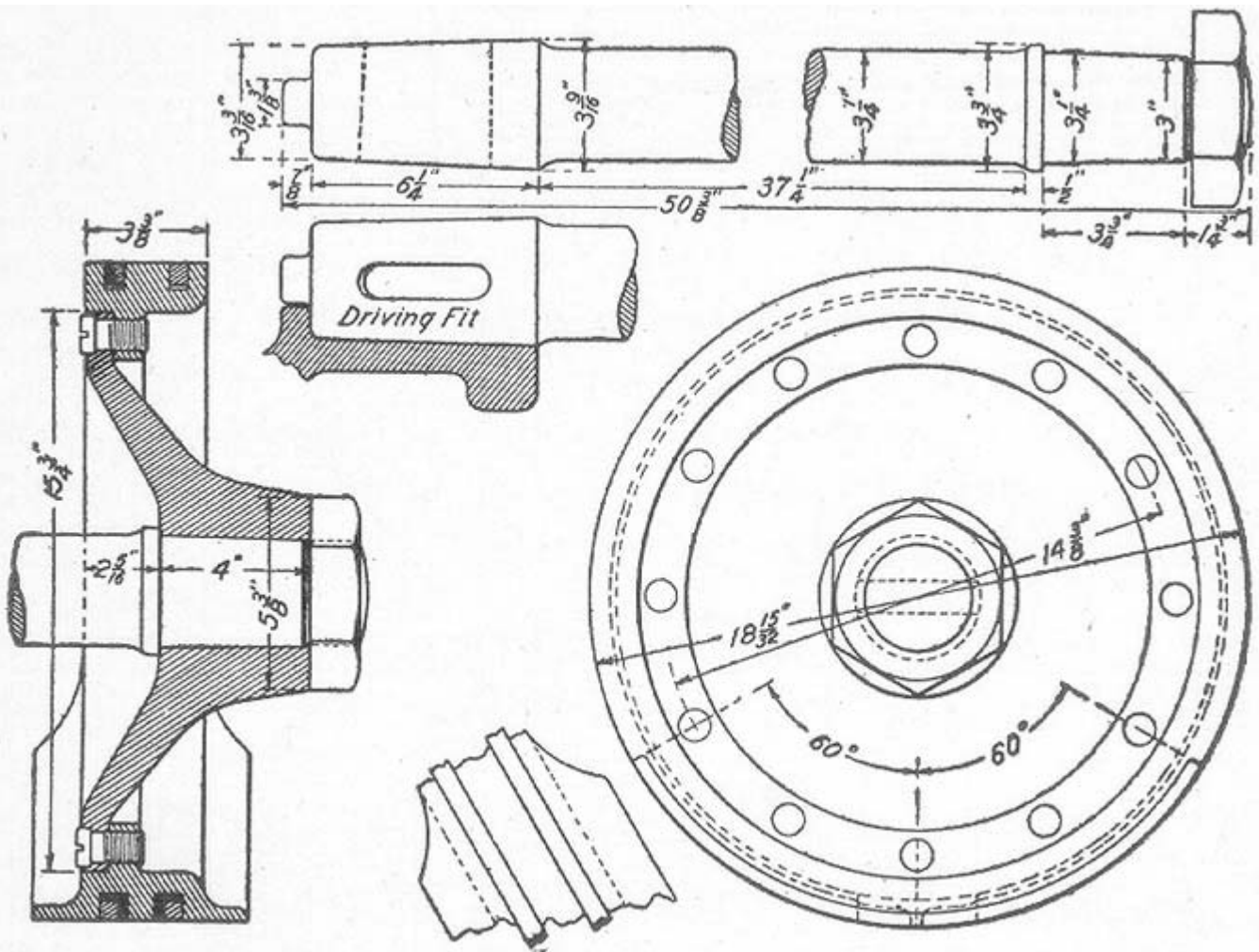

Fig. 79. Piston and Rods of Modern Locomotives.

**Crossheads and Guides.** A variety of forms of crossheads and guides are now found in use on locomotives, two of the most common of which are illustrated in [Fig. 80](#) and [Fig. 81](#). The form illustrated in [Fig. 80](#) is known as the *4-bar guide* and that shown in [Fig. 81](#), as the *2-bar guide*. The form used depends largely on the type of engine. The 4-bar guide now used on light engines consists of four bars *A* which form the guide with the crosshead *B* between them. The bars are usually made of steel and the crosshead of cast-steel having babbitted wearing surfaces. The 4-bars *A* are bolted to the guide blocks *C* and *D* which are held by the back cylinder head and the guide yoke *E*, respectively. The guide yoke *E* is made of steel, extends from one side of the locomotive to the other, is securely bolted to both frames, and serves to hold the rear end of both guides. There is usually a very strong brace connected to the guide yoke which is riveted to the boiler. The wrist pin used in the crosshead of the 4-bar type is cast solid with the crosshead.

The 2-bar guide consists of two bars, one above and one below the center line of the cylinder with the crosshead between them. In this type the parts are more accessible for making adjustments and repairs and the wrist pin is made separate from the crosshead.

In the design of the crosshead, the wearing surface must be made large enough to prevent heating. In practice it has been found that for passenger locomotives the maximum pressure between the cross-head and guides should be about 40 pounds per square inch

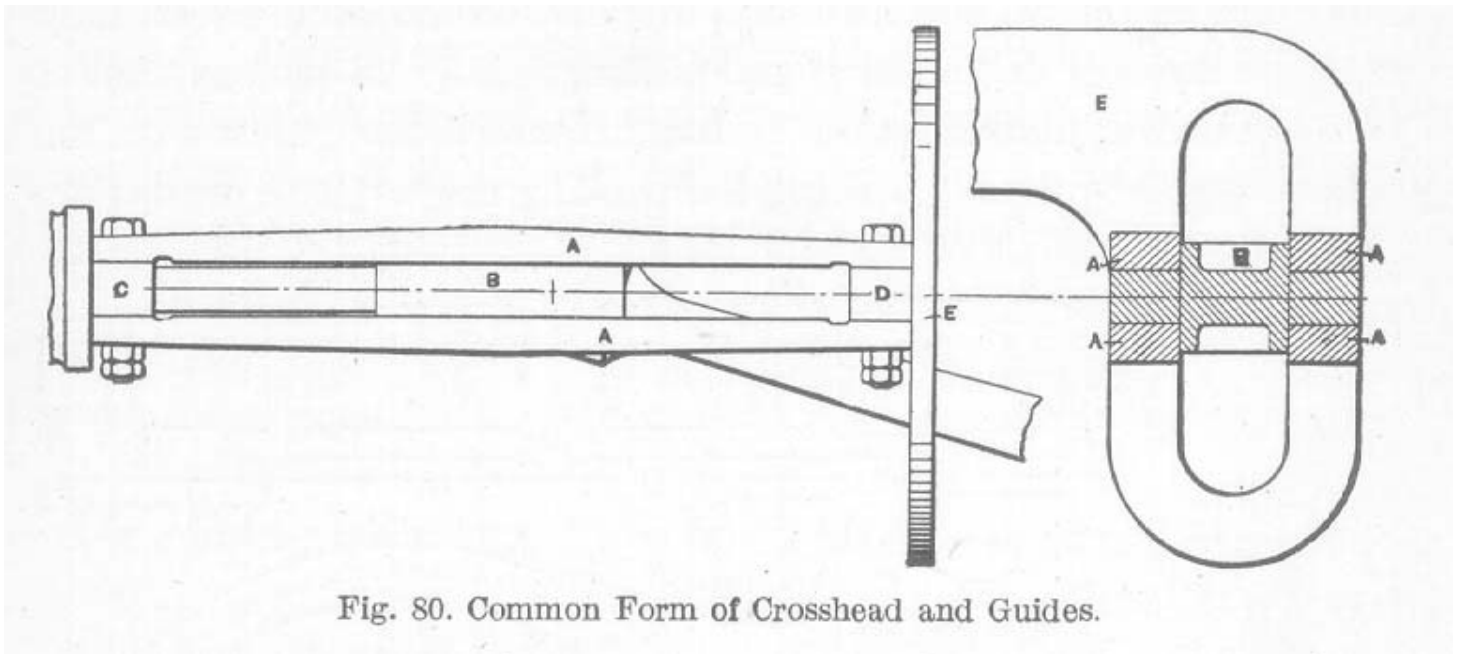

Fig. 80. Common Form of Crosshead and Guides.

while for freight locomotives it may be as high as 50 pounds per square inch. For crosshead pins, the allowable pressure per square inch of projected area is usually assumed at 4,800 pounds, the load on the pin to be considered as follows: For simple engines, the total pressure on the pin is taken to be equal to the area of the piston in square inches multiplied by the boiler pressure in pounds per square inch; for compound engines of the tandem and Vaucrain types, the total pressure on the pin is taken to be equal to the area of the low-pressure piston in square inches multiplied by the boiler pressure in pounds per square inch, the whole being divided by the cylinder ratio plus 1. In the latter case, the cylinder ratio equals the area of the high-pressure cylinder divided by that of the low-pressure cylinder.

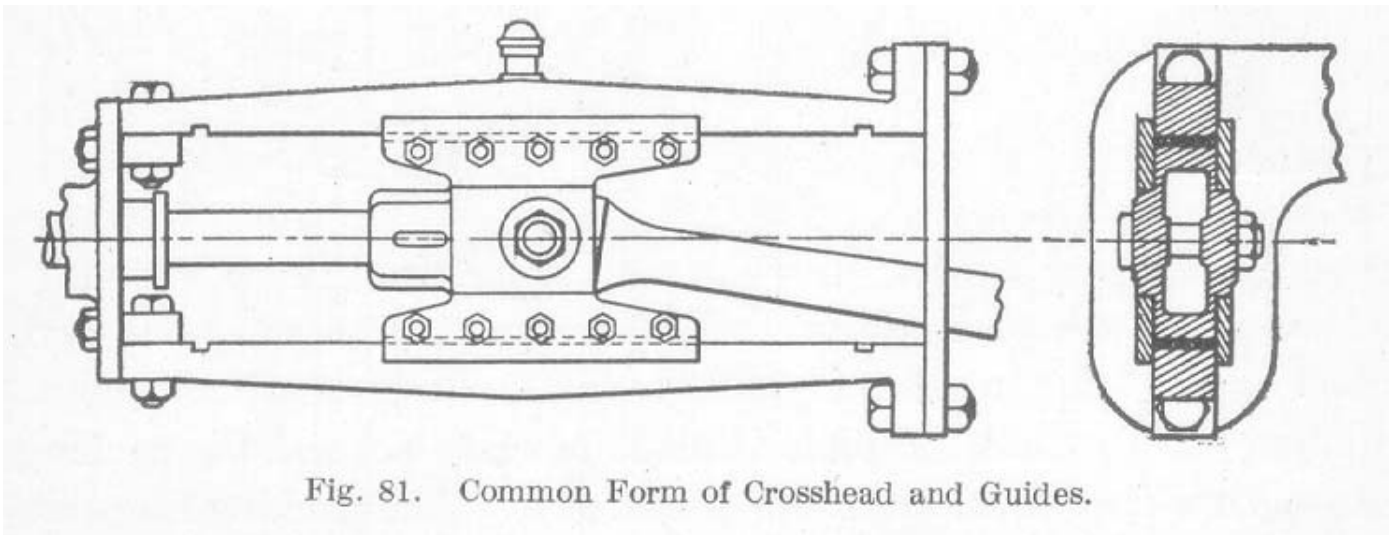

Fig. 81. Common Form of Crosshead and Guides.

**Connecting or Main Rods.** Connecting or main rods are made of steel, the section of which is that of an I. The I-section gives the greatest strength with a minimum weight of metal. [Fig. 82](#) illustrates modern practice in the design of connecting rods for a heavy locomotive. The design for passenger locomotives is quite similar to that shown. Aside from the general dimensions and weight of the rod, there are to be noted some important



details in the manner in which the brasses are held and the means provided for adjusting them. The older forms of rods had a stub end at the crank pin end with a strap bolted to the rod. A key was used in adjusting the brasses. With the building of locomotives of greater capacity, this construction was found to be weak. The connecting rod shown in [Fig. 82](#) has passed through several stages in the process of its development. The crank end is slotted, the brasses being fitted between the upper and lower jaw. The brasses are held in place by a heavy cotter *A* and a key *B*. The cotter is made in a form which prevents the spread of the jaws *C* and *D*. The adjustment of the brasses is made by means of the key *B* in the usual way. The brasses at the crosshead end are adjusted by the wedge *E*. The oil cups are forged solidly on the rod.

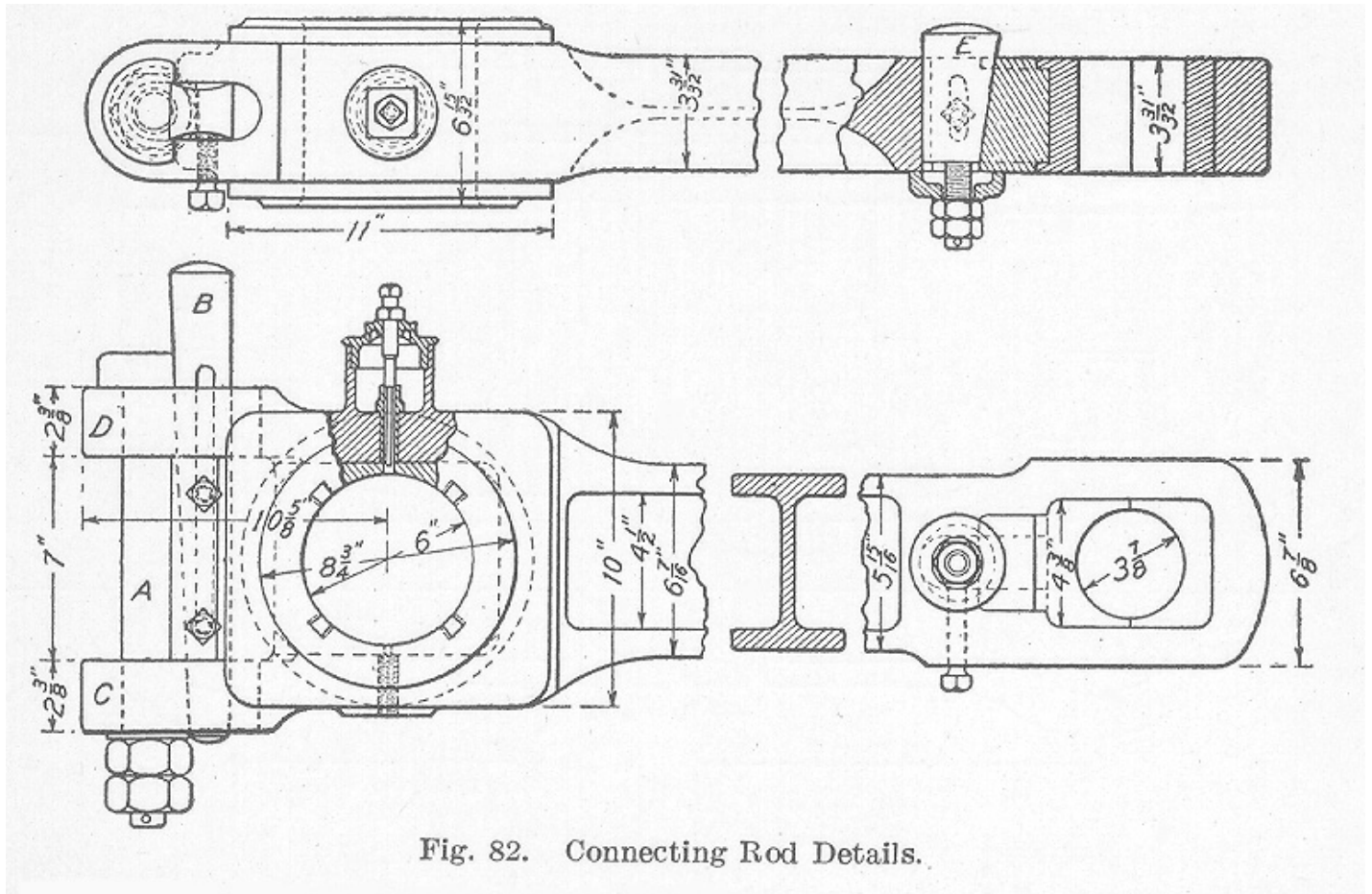

Fig. 82. Connecting Rod Details.

**The Parallel or Side Rods.** The parallel or side rods are also made with an **I**-section in order to obtain a maximum strength with a minimum weight of metal. [Fig. 83](#) illustrates the form of side rods now being used. The rods are forged out of steel, in the same manner as connecting rods, having oil cups also forged on. The enlarged ends are bored for the brasses which are made solid and forced in by hydraulic pressure. In case the locomotive is one having more than two pairs of drivers, the side rods are connected by means of a hinged joint as shown at *A*, [Fig. 84](#).

Both connecting rods and side rods are subjected to very severe stresses. They must be capable of transmitting tensional, compressional, and bending stresses. These stresses are brought about by the thrust and pull on the piston and by centrifugal force.

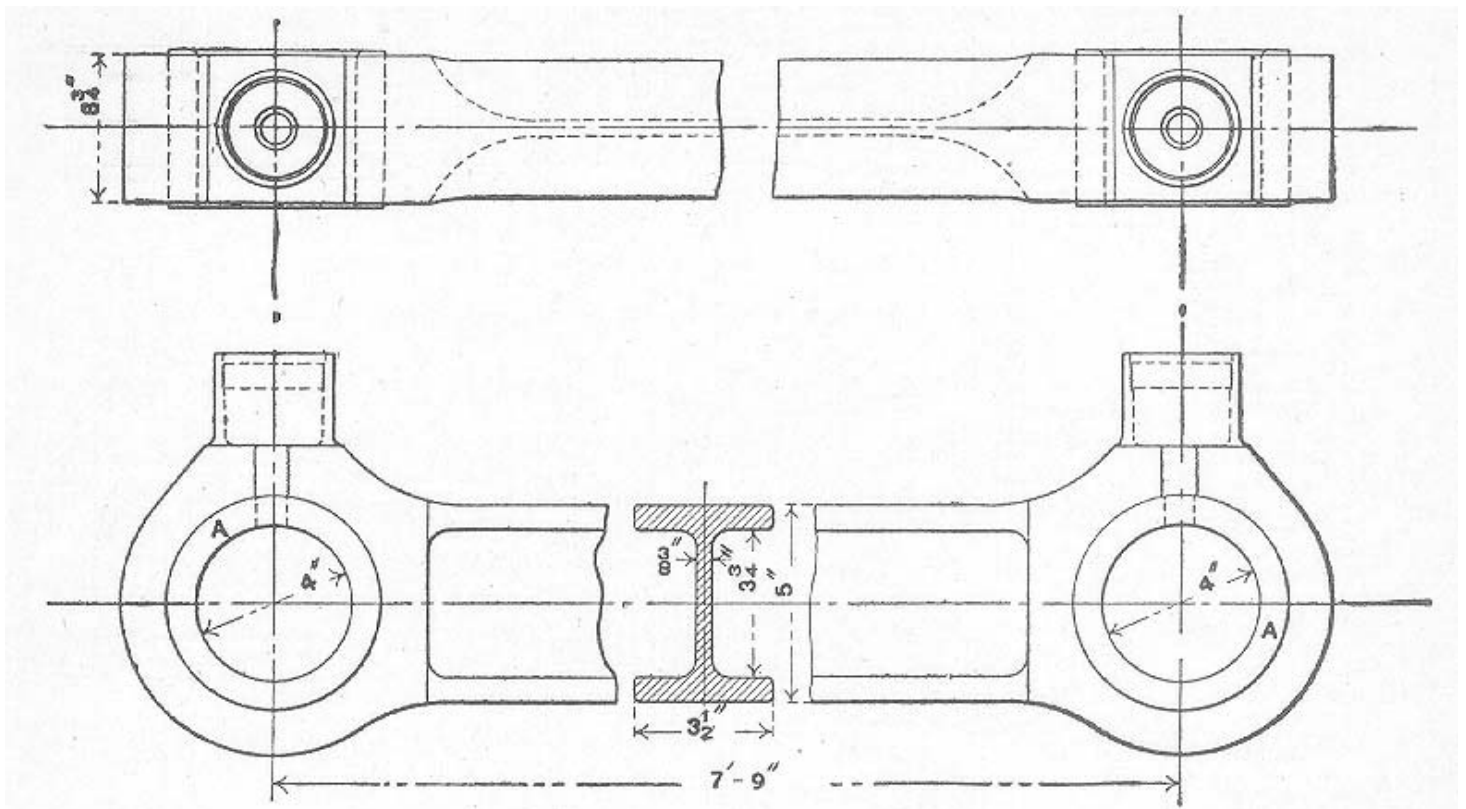

Fig. 83. Side Rod.

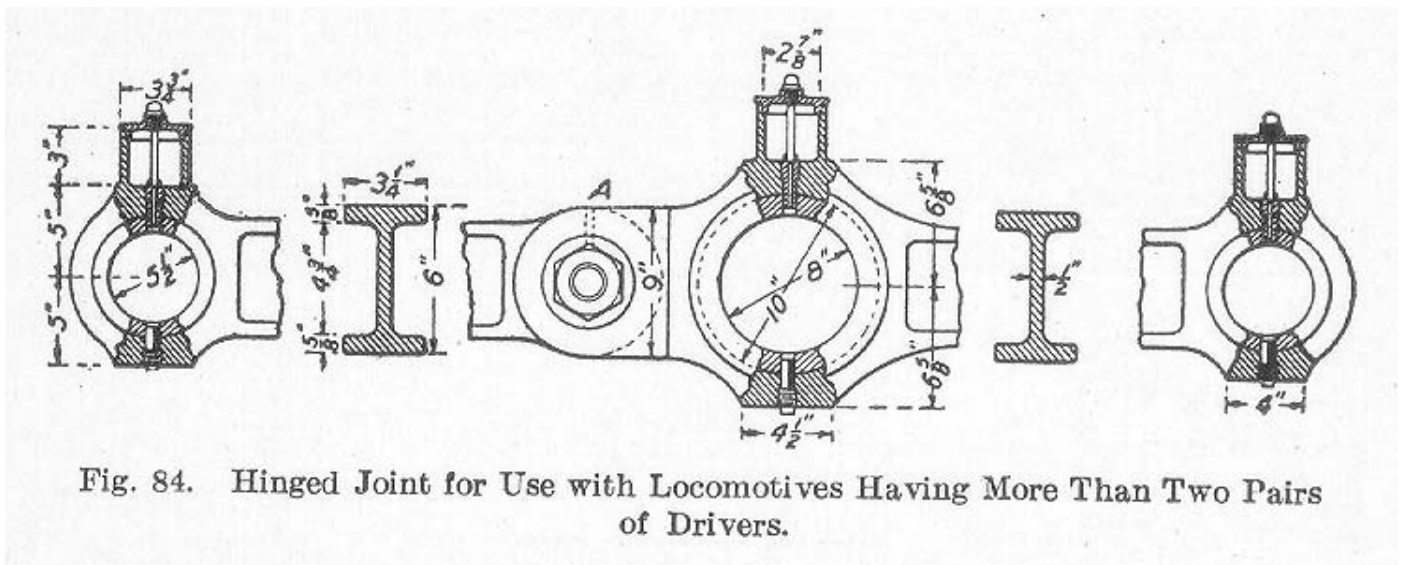

Fig. 84. Hinged Joint for Use with Locomotives Having More Than Two Pairs of Drivers.

**Locomotive Trucks.** The trucks commonly used under the front end of locomotives are of two types, namely, the *two-wheeled* or *pony truck* and the *four-wheeled truck*.

The pony truck, illustrated in [Fig. 85](#), consists essentially of the two wheels and axle, the frame, 1, which carries the weight of the front end of the locomotive and the radius bar, 2, pivoted to the cross bar, 3, which is rigidly bolted to the engine frame, 4. The radius bars serve to steady the truck and reduce the flange wear on the wheels when running on

curves. A side movement is provided for at the center plate, which is made necessary on account of curves. The correct length of the radius bar is given by the following formula:

$$X = \frac{D R + D^2}{R + 2 D}$$

where

R = length of rigid wheel base of engine in feet

D = distance in feet from front flanged driver axle to center of truck

X = length in feet of radius bar

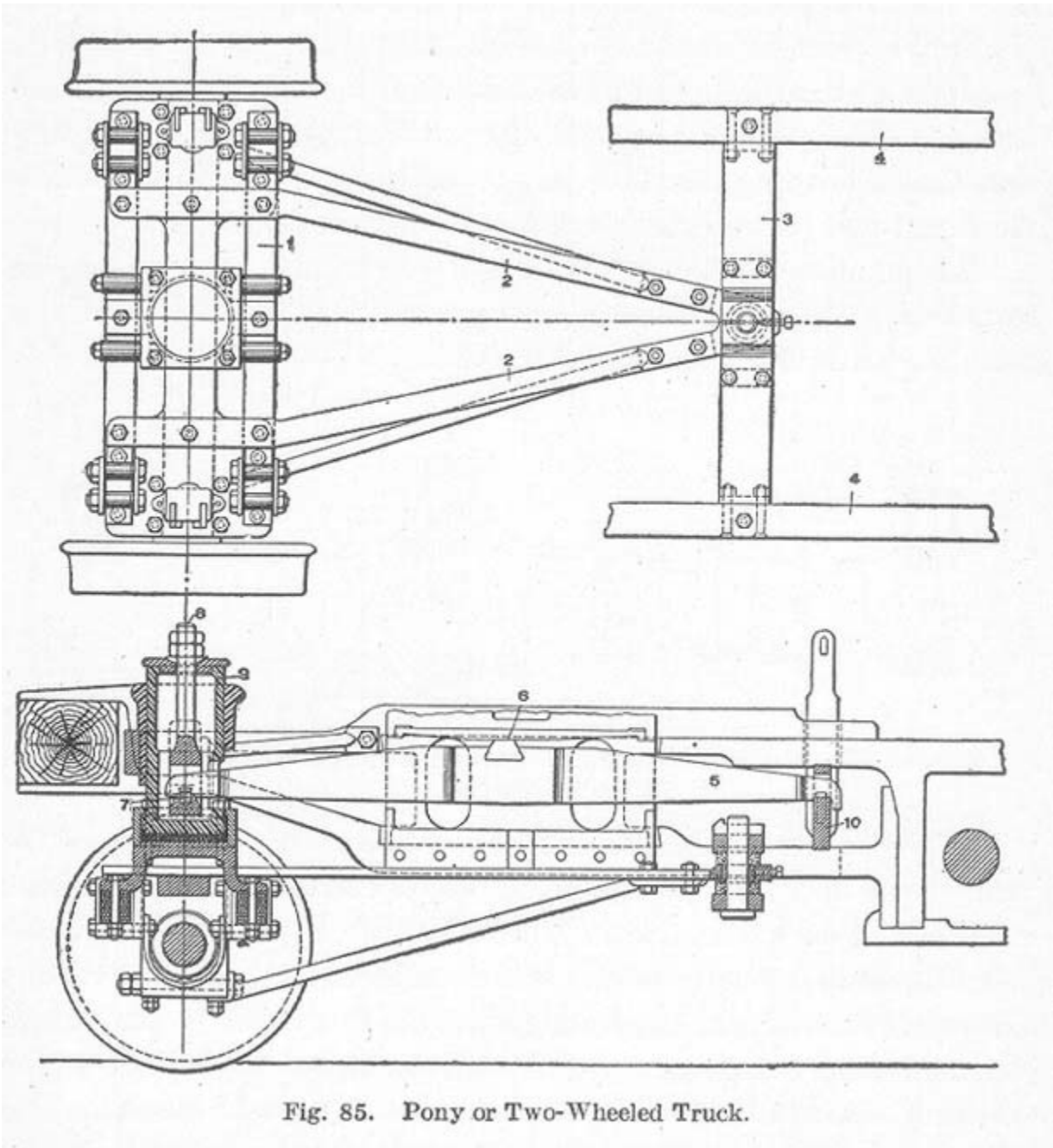
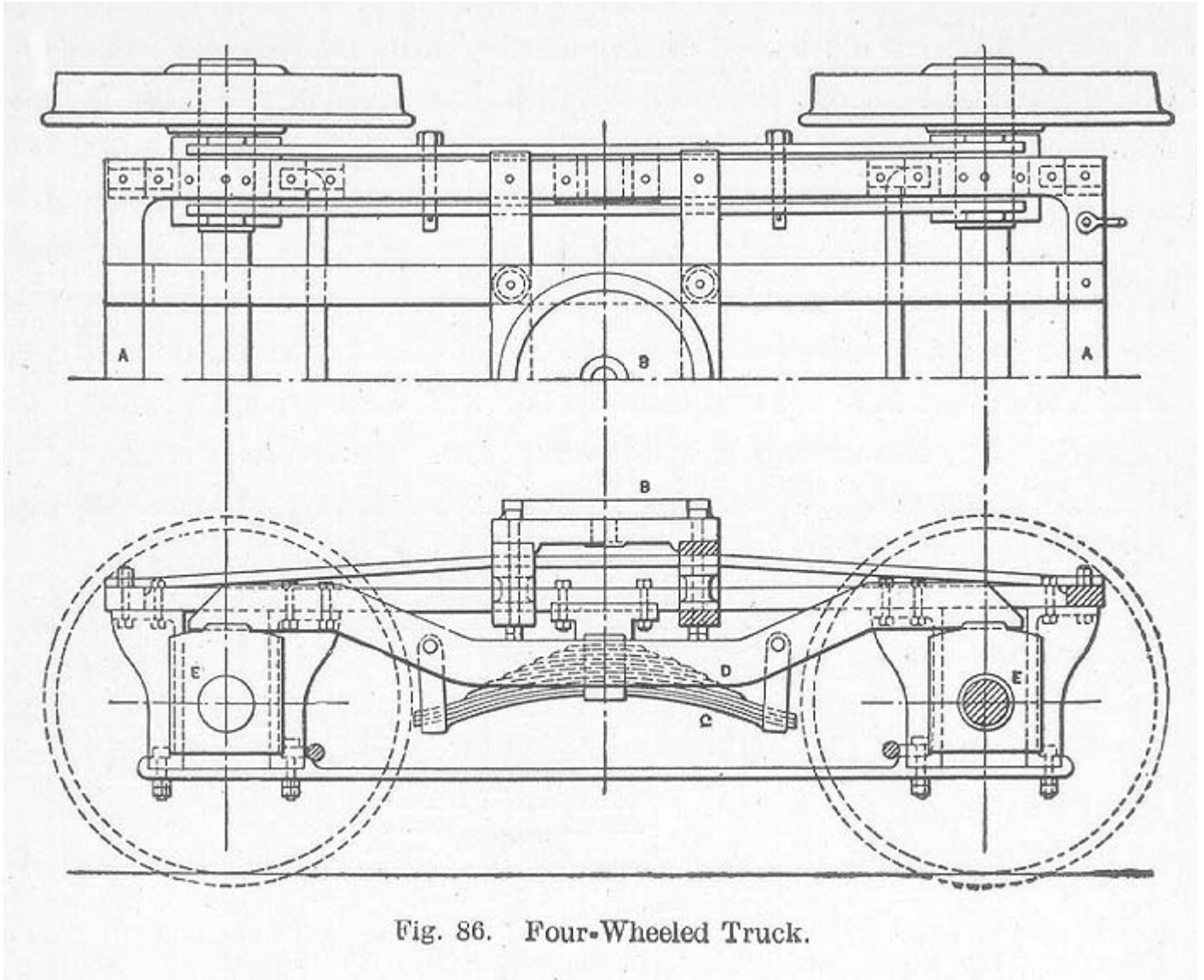

Fig. 85. Pony or Two-Wheeled Truck.



The usual method of applying the weight to a pony truck is by means of the equalizing lever, 5. The fulcrum, 6, of this equalizing lever is located under the cylinders where the weight is applied. The front end of the equalizing lever is carried by the pin, 8, which, in turn, is carried by the sleeve, 9, and transmits the load to the center plate while the rear end of the lever is supported by means of the cross lever, 10, which is carried by the driving wheel springs.



The four-wheeled truck is constructed in a number of different ways, one of which is illustrated in [Fig. 86](#). The construction is simple, consisting of a rectangular frame, *A*, carrying a center plate, *B*. As in the case of the pony truck, the journals are inside of the wheels. The truck, which is pivoted on the center plate, carries the front-end of the locomotive and serves as a guide for the other wheels of the locomotive.

The object in using a trailing truck, as stated earlier in this work, is to make possible the wide fire box which is necessary in certain types of locomotives. Two different types of trailing trucks are used and both have proven successful. One has an inside bearing, as illustrated in [Fig. 87](#), and the other an outside bearing, as shown in [Fig. 88](#). The former is

perhaps the simpler of the two. The latter has a broad supporting base which improves the riding qualities of the locomotive.

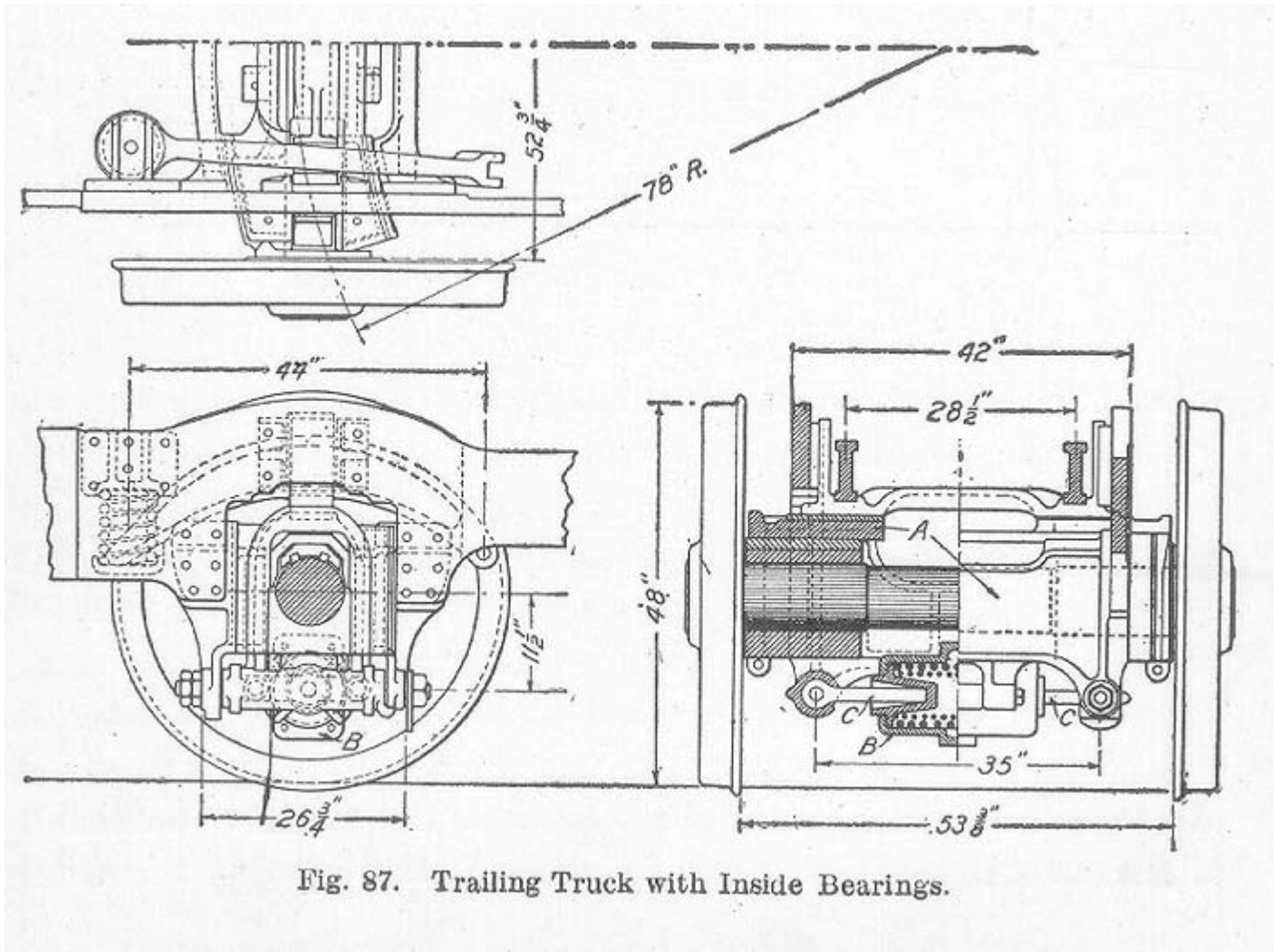

Fig. 87. Trailing Truck with Inside Bearings.

The radial trailing truck with inside bearings. [Fig. 87](#), is fitted with a continuous axle box, *A*, with journal bearings at each end, these being provided at the frame pedestals with front and back wearing surfaces formed to arcs of concentric circles of suitable radii. To the lower face of the continuous axle box is attached a spring housing, *B*, fitted with transverse coiled springs having followers and fitted with horizontal thrust rods, *C*, which extend to the pedestal tie bars. These thrust bars terminate in ball and socket connections at each end. This combination of springs and thrust rods permits the truck to travel in a circular path and also permits the continuous axle box to rise and fall relatively to the frames. Motion along the circular arcs is limited by stops at the central spring casing, the springs tending to bring the truck to its normal central position when the locomotive passes upon a tangent from a curve. The load is transmitted to the continuous axle box through cradles on which the springs and equalizers bear, hardened steel sliding plates being interposed as wearing surfaces immediately over the journal bearings. The cradles are guided vertically by guides attached to the locomotive frames.

The radial trailing truck with outside bearings, as illustrated in [Fig. 88](#), has journal boxes *A* rigidly attached to the frame, the forward rails of which converge to a point in which the pivot pin *B* is centered. The pin is fixed in a cross brace secured between the engine

frames. The trailing truck frame extends back of the journal boxes in the form of the letter *U* at the center of which a spring housing *C* is mounted, containing centering springs and followers, performing the same functions as those of the radial truck with inside bearings, already described. The load in this case is transmitted to the journal boxes by springs which are vertically guided. Hardened rollers are generally used between what would otherwise be sliding surfaces. These rollers rest upon double inclined planes which tend to draw the truck to its normal and central position when displaced laterally as on a curve. The mutual action of these rollers and inclined planes is to furnish a yielding resistance to lateral displacement with a tendency to return to the normal position.

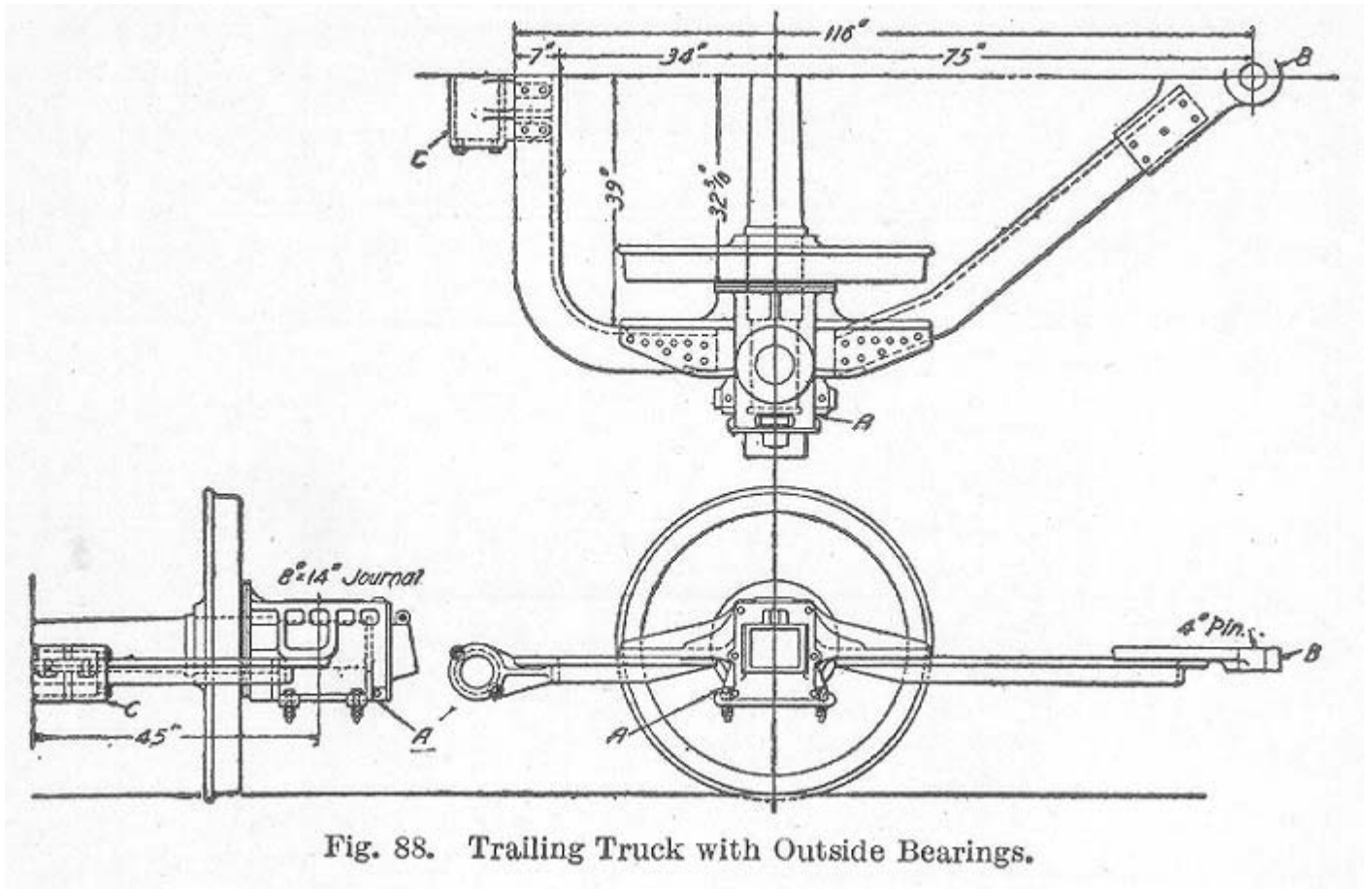

Fig. 88. Trailing Truck with Outside Bearings.

**The Tender.** The tender of a locomotive is used to carry the coal and water supply for the boiler. It is carried on two four-wheeled trucks having a frame work of wood or steel, the latter being mostly used at the present time. This frame supports the tank in which the water is stored, which, in the case of passenger and freight locomotives, is usually constructed in the shape of the letter *U*, the open end of which faces the fire door. The open space between the legs of the *U* is used for coal storage. The water is drawn from the tank near the two front corners. In these two front corners are placed tank valves which are connected by means of the tank hose and pipes to the two injectors. Near the back end of the tank is a manhole which permits a man to enter the inside to make repairs. This opening is also used in filling the tank at water towers. Tanks are made of open hearth steel, usually about  $\frac{1}{4}$  of an inch in thickness, the sheets being carefully riveted together to prevent leaks. The interior of the tank is well braced and contains



baffle plates which prevent the water from surging back and forth, due to curves and shocks in the train itself. The tank is firmly bolted to the frame.

Many of the engines designed for southern and western traffic burn oil and, as a rule, the railroads themselves furnish the specifications for the oil-burning equipment. Cylindrical tanks are used on the tender with the water tank forward, as a rule. Otherwise, the tender design is the same as for coal-burning locomotives.

The capacity of tenders has been increased as the locomotives which they serve have grown in size and power. Modern heavy locomotive tenders have a water capacity of from 3,000 to 9,000 gallons and a coal capacity of from 5 to 16 tons.

On switching engines, the back end of the tank is frequently made sloping in order to permit the engineer to see the track near the engine when running backward. Frequently a tool box is placed near the rear of the tank in which may be kept jacks, replacers, etc. A tool box for small tools and signals is usually placed at the front of the tender on either side. The coal is prevented from falling out at the front end by using gates or boards dropped into a suitably constructed groove. On locomotives used on northern railroads, the tanks are provided with a coil of steam pipes by means of which the water can be warmed and prevented from freezing.

**Locomotive Stokers.** The amount of water a locomotive boiler is capable of evaporating is limited by a number of conditions. It is possible to construct a locomotive of such dimensions that it would be capable of burning an amount of coal which would be physically impossible for a fireman to handle. Furthermore, the different methods of firing a locomotive by hand, as practiced by many firemen, are frequently very uneconomical and result in a great loss of fuel. Again, there are certain heavy freight runs on some railroads which require two firemen in order to get the train through on schedule time.

The above reasons and many others which might be mentioned have resulted in a demand for some form of automatic or mechanical stoker for locomotive work. In the last ten or fifteen years, much experimental work has been done along this line and a number of different types of stokers have been developed which have met with some success.

A locomotive stoker to be successful should meet the following requirements:

1. It should be able to handle any desired quantity of coal and at the same time call for less physical effort on the part of the fireman than is required in hand firing.
2. It should be able to successfully handle any grade of coal.
3. It should be able to maintain full steam pressure under all conditions.
4. It should not become inoperative under ordinary conditions of service.
5. Its construction should permit of hand firing to meet emergency conditions.

Of the many types of locomotive stokers which have been developed and tried out, the following makes are characteristic and will serve for illustration.

*Chain Grate Stoker.* The chain grate stoker, invented as early as 1850, was thought at first to have solved the smoke problem. It was used to a limited extent in and about New York City, but for various reasons was soon abandoned. Its construction was quite similar to our present-day chain grate commonly used in power-plant work. It was mounted on wheels and could be drawn out of the fire-box on a track. Coal was shoveled into a hopper by the fireman and the chain grate was operated by a small auxiliary steam engine.

*Hanna Locomotive Stoker.* The Hanna locomotive stoker, developed by W. T. Hanna, is so constructed that the entire apparatus is readily applicable to any locomotive and is placed in the cab. It makes use of the ordinary fire door as a place through which the coal is jettied into the fire-box. It is operated by a small double-acting twin-engine placed in the floor of the cab, which serves to drive a screw propeller, which in turn causes the coal to be pushed upward and forward through a large pipe leading to the fire door. The engine can be reversed by means of a reversing valve, which changes the main valve from outside admission to inside admission.

Coal is shoveled into a hopper and from the hopper it is carried by the stoker mechanism to a distributing plate immediately inside of the fire door. From the distributing plate, the coal is thrown into the fire-box by the action of a number of steam jets which radiate from a central point on the plate. The speed of the small operating engine controls the rate of firing. Deflector and guide plates, located just inside of the fire door, are so arranged and under control of the fireman that the coal can be placed on any portion of the grate desired.

This stoker requires much physical work on the part of the fireman, since the coal must be broken into small lumps and the hopper kept filled. The larger lumps of coal will be deposited near the rear part of the grate, the finer particles being blown to the front portion. Much of the finer particles of coal will burn as dust and a part will be drawn through the flues without being burned at all.

*Street Mechanical Stoker.* The Street mechanical stoker consists of a small steam engine bolted to the top and left side of the back head of the boiler, which drives a worm gear and operates a chain conveyor. The conveyor bucket elevates the crushed coal from a hopper below and drops it on a distribution plate, located just inside of the fire door. From the distributing plate the coal is thrown into the fire-box by an intermittent steam jet, which is under the control of the fireman. There is a coal crusher on the tender, which is driven by another small steam engine. The coal, after being crushed, falls down a 45-degree inclined spout to the hopper below the deck. Some of the later designs use a screw propeller to carry the crushed coal from the tender to the hopper. The Street stoker does not require a great amount of physical work by the fireman. The large lumps of coal will fall near the rear portion of the grate as in the case of the Hanna stoker.

*Crawford Mechanical Underfeed Stoker.* The Crawford mechanical underfeed stoker, invented by D. F. Crawford, S.M.P. of the Pennsylvania Lines west of Pittsburgh, has been tried out on the Pennsylvania Lines and has given very satisfactory service. This stoker takes coal from beneath the tender and by means of a conveyor carries it forward to a hopper. From the hopper, two plungers, placed side by side, push the coal still farther ahead where two other plungers, one on each side, cause the coal to be pushed up through narrow openings to the ordinary shaking grate. Both the conveyor and the plungers are

operated by a steam cylinder, containing a piston operated by the ordinary nine and one-half-inch Westinghouse air-pump steam valve. The conveyor consists of a series of lunged partitions, or doors, which carry the coal in one direction and slide over it when the motion is reversed. If the conveyor for any reason should become inoperative, a door in the deck can be opened and coal shoveled into the hopper below. If the stoking device should become inoperative, then coal can be fired by hand in the usual way. This stoker requires a minimum amount of physical labor from the fireman. It can be applied to any locomotive, but only at considerable cost. Its application reduces the grate area to a certain extent and thus reduces the steaming capacity of the boiler.

## DESIGN OF PARTS OF THE ENGINE

The design of the parts of the locomotive engine proper, like that of the boiler, is a subject which cannot be handled properly in the space allotted in this book. These designs are the result of a gradual development of the proper proportions based upon the tests of each part in actual service. The specifications for materials and workmanship are rigidly drawn and as carefully lived up to, for in railroad service the chances for failure of any part of the engine, because of the excessive vibration, are many, and the destructive effect of such failure is out of all proportion to the original manufacturing expense. These conditions, therefore, make perfect action and excessive reliability prime necessities in engine design. A few formulas, for the most part based on rational assumptions, are presented for the calculation of some of the most important parts.

**Axles.** The stress in the axles is combined in many ways. The principal stresses are, first, bending stresses due to the steam pressure on the piston; second, bending stresses due to the dead weight of the engine; third, torsional or shearing stresses due to unequal adhesion of the wheels on the rails; and fourth, bending stresses due to the action of the flanges on the rails while rounding curves. Let

$W$  = the area of the piston in square inches multiplied by the boiler pressure in pounds per square inch

$L_1$  = the lever arm in inches or the distance from the center of the main or connecting rod to the center line of the frame

$O$  = the lever arm in inches or the distance from the center of the side rod to the center line of the frame

$M$  = bending moment or the load in pounds times the lever arm in inches

$d$  = the diameter of axle in inches

$R$  = the section modulus which for a solid circular section  
=  $.0982 d^3$

If there are only two pairs of drivers, the force  $W$  will be equally distributed between the crank pins as shown in *A*, Fig. 89.

If the force  $W$ , the total steam on the piston, is assumed to act alone, the maximum fiber stress in pounds per square inch produced in the axle will be

$$S_1 = \frac{W L_1}{2 R}$$

for the main axle, and

$$S_1 = \frac{W O}{2 R}$$

for the back axle.

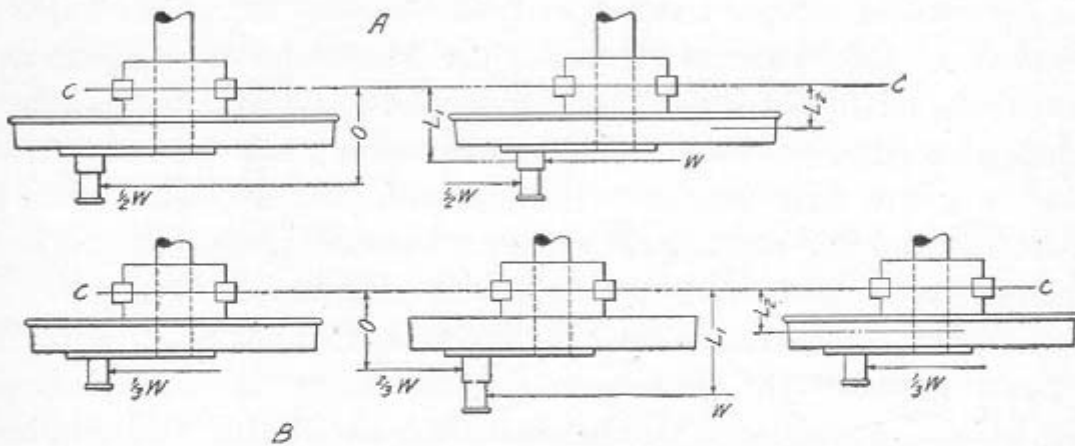

Fig 89. Force Diagram for Drivers.

Let

$W_1$  = the dead load in pounds on each journal

and

$L_2$  = lever arm in inches or the distance from the center of the driving box or frame to the center line of the rail.

Then, if the force  $W_1$  be assumed to act alone, the maximum fiber stress in pounds per square inch produced in the axle will be

$$S_2 = \frac{W_1 L_2}{R}$$



Let

$L_3$  = the crank radius, or one-half the length of the stroke in inches.

If the twisting of the axle alone is considered, the torsional or shearing stress in pounds per square inch produced in the axle will be

$$S_3 = \frac{W L_3}{2 R}$$

Because of certain existing conditions which affect the amount of torsion or twisting of the axle, only one-half of the theoretical stress should be used, as it is not probable that under any circumstances could more be transmitted by the axle to the opposite side.

Let

$D$  = the diameter of drivers in inches

$F$  = the centrifugal force in pounds

$W_2$  = the weight in pounds of the moving mass of wheels plus the weight carried by them

$g$  = the acceleration of gravity in feet per second = 32.2

$r$  = the radius of curvature of the track in feet

$v$  = the velocity of the locomotive in feet per second

If the action on a curve alone is considered, the maximum fiber stress in pounds per square inch produced in the axle will be

$$S_4 = \frac{F D}{2 R}$$

where

$$F = \frac{W_2 v^2}{r g}$$

Considering all stresses acting together, we get the resultant maximum fiber stress in pounds per square inch in the axle to be

$$S'' = \frac{S'}{2} + \sqrt{\frac{(S')^2}{4} + \frac{(S_3)^2}{2}}$$

where

$$S' = \sqrt{(S_1)^2 + (S_2)^2}$$

In this equation, the bending stress due to the centrifugal force while rounding curves does not appear since it is assumed that this will neutralize that due to the dead load on the axle.

The following allowable fiber stresses in pounds per square inch have been used in successful designs:

TABLE XVII  
Fiber Stresses

TYPE OF LOCOMOTIVE	IRON	STEEL
Consolidation	7,500	8,500
10 wheel or Mogul	8,500	9,500
8 wheel passenger	10,500	13,000

*Example.* Determine the fiber stresses in the driving axle of an 8-wheel passenger locomotive having the following dimensions: cylinder 20 inches in diameter, length of stroke 26 inches, steam pressure 200 pounds per square inch, and other dimensions as listed:

- $O = 21.5$  inches
- $R = 65.77$  for an axle  $8\frac{3}{4}$  inches in diameter
- $W_1 = 18,000$  pounds
- $L_2 = 7\frac{1}{2}$  inches
- $L_3 = 13$  inches
- $D = 75$  inches
- $g = 32.2$
- $r = 955$  feet
- $v = 88$  feet per second (60 miles per hour)
- $W_2 = 42,500$  pounds

SOLUTION.

$$\begin{aligned}
 S_1 &= \frac{W O}{2 R} = \frac{62700 \times 21.5}{2 \times 65.77} \\
 &= 10250 \text{ pounds per square inch} \\
 S_2 &= \frac{W_1 L_2}{R} = \frac{18000 \times 7.5}{65.77} \\
 &= 2050 \text{ pounds per square inch} \\
 S_3 &= \frac{W L_3}{2 R} = \frac{62700 \times 13}{2 \times 65.77} \\
 &= 6200 \text{ pounds per square inch.}
 \end{aligned}$$

As previously stated, this value would probably never exceed one-half this amount, which assumption gives a fiber stress of 3,100 pounds per square inch.

$$\begin{aligned}
 F &= \frac{W_2 v^2}{r g} = \frac{42500 \times (88)^2}{955 \times 32.2} \\
 &= 10700 \text{ pounds} \\
 S_4 &= \frac{F D}{2 R} = \frac{10700 \times 75}{2 \times 65.77} \\
 &= 6055 \text{ pounds per square inch}
 \end{aligned}$$

The flange pressure would probably not exceed one-third of the total centrifugal force, the remainder being absorbed by the elevation of the outer rail. If this were true, then

$$S_4 = \frac{6055}{3} = 2018 \text{ pounds per square inch}$$

which, as can be seen, just about neutralizes the stress due to the dead weight.

$$\begin{aligned}
 S' &= \sqrt{(S_1)^2 + (S_2)^2} \\
 &= \sqrt{10250^2 + 2050^2} \\
 &= 10450 \text{ pounds per square inch}
 \end{aligned}$$

Therefore,

$$\begin{aligned}
 S'' &= \frac{S'}{2} + \sqrt{\frac{(S')^2}{4} + \frac{(S_3)^2}{2}} \\
 &= \frac{10450}{2} + \sqrt{\frac{(10450)^2}{4} + \frac{(3100)^2}{2}} \\
 &= 10990 \text{ pounds per square inch}
 \end{aligned}$$

Therefore, an 8¾ steel axle is large enough for an 8-wheel passenger locomotive since the allowable fiber stress of 13,000 pounds per square inch is not exceeded.

If the locomotive under consideration was one having three pairs of drivers instead of two, the total piston pressure would be distributed as shown in *B*, [Fig. 78](#).

**Crank Pins.** Crank pins are calculated for strength by the following methods:

In *A*, *K*, and *C*, Fig. 90, is shown the manner in which the forces act on the crank pins of three-different types of locomotives.

Let

$W$  = the boiler pressure in pounds per square inch, times area of the piston in square inches

$S$  = the safe fiber stress in pounds per square inch

$L$  = the lever arm in inches or the distance from the face of the wheel to the center of the main rod

$M$  = maximum moment in inch pounds or force in pounds times the lever arm in inches

$P_1$  = the force in pounds transmitted to the side rod

$d$  = the diameter of crank pin in inches

$L_1$  = the side rod lever arm in inches or the distance from the face of the wheel center to the center line of the side rod

$R$  = the section modulus of the crank pin which for a circular section =  $.0982 d^3$

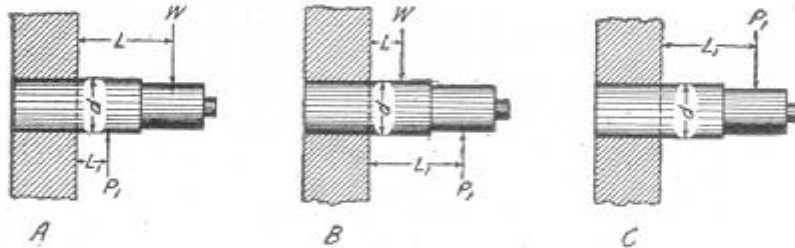

Fig. 90. Action of Force on Crank Pins in Different Types of Locomotives.

Having given the above conditions, we may write

$$M = W L - P_1 L_1$$

and

$$S = \frac{M}{R} = \frac{M}{.0982 d^3}$$

From this last equation

$$d^3 = \frac{M}{.0982 S}$$

Finally, substituting the value of  $M$  we get

$$d = \sqrt[3]{\frac{W L - P_1 L_1}{.0982 S}}$$

This equation may be used in finding the diameter of the main crank pin on any type of locomotive when the loads and lever arms are known and the safe fiber stress has been assumed. It should be remembered, however, that for an 8-wheeled locomotive it is

$$P_1 = \frac{W}{2}$$

and for a 10-wheeled locomotive it is

$$P_1 = \frac{W}{3}$$

For crank pins other than main pins on engines having the main rod on the outside, no calculations need be made for bending.

To calculate the back pin, the load is applied as shown in *C*, Fig. 80, and we have

$$M = P_1 L_1$$

and finally

$$d = \sqrt[3]{\frac{P_1 L_1}{.0982 S}}$$

The maximum allowable working stress in pounds per square inch for crank pins is as follows:

TABLE XVIII  
Working Stress for Crank Pins

CLASS OF LOCOMOTIVES	STEEL	IRON
Freight locomotive	15,000	12,000
Passenger locomotive	12,000	10,000

In addition to figuring the crank pins for bending, the bearing surface must be given some attention. In order to prevent overheating and to secure the best results, the pin must be designed so that the unit pressure will not exceed an amount determined by past experience. This allowable pressure in practice varies from 1,600 to 1,700 pounds per square inch of projected area, the projected area being the diameter of the pin multiplied by its length. It often happens that it is necessary to make the pin larger than is required for safe strength in order that the allowable bearing pressure may not be exceeded.

**Piston Rods.** Because of the peculiar conditions of stress and loading of a piston rod, a very high factor of safety must be used in its design. It is subjected to both tensional and compressional stresses and must be capable of resisting buckling when in compression. Reuleaux gives the following formulae for determining the diameter of piston rods:

Considering tension alone

$$d = .0108 D \sqrt{P}$$

and considering buckling

$$d = .0295 D \sqrt{\frac{L}{D}} \sqrt[4]{P}$$

where

$D$  = diameter of cylinder in inches

$d$  = smallest diameter of piston rod in inches

$L$  = length of the piston rod in inches

$P$  = the boiler pressure in pounds per square inch

*Example.* Given a locomotive having cylinders 20 inches in diameter, piston rod 46 inches long, and carrying a boiler pressure of 190 pounds per square inch. Determine the diameter of the piston rod necessary.

**SOLUTION.** Considering the problem from the standpoint of tension only, we have

$$\begin{aligned} d &= .0108 \times 20 \sqrt{190} \\ &= 2.98 \text{ inches} \end{aligned}$$

The dimensions of the rod determined from the standpoint of buckling would be

$$\begin{aligned} d &= .0295 \times 20 \sqrt{\frac{46}{20}} \sqrt[4]{190} \\ &= 3.3 \text{ inches} \end{aligned}$$

The size which would probably be used would be, say, 3½ inches, which would allow for wear.

From the above figures, it is evident that if a piston rod is made strong enough to withstand buckling, it will be sufficiently large to resist the tensional stresses which may come upon it.

**Frames.** As has been previously stated, the frames of a locomotive are very difficult to design because of the many unknown factors which affect the stresses in them. The following method of proportioning wrought-iron and cast-steel frames will give safe values for size of parts although the results thus found will be greater than usually found in practice.

Let



$P$  = the thrust on the piston or the area of the piston in square inches multiplied by the boiler pressure in pounds per inch

$A$  = the area in square inches of the section of the frame at the top of the pedestal

$B$  = the area in square inches of the section of the frame at the rail between the pedestals

$C$  = the area in square inches of the section of the lower frame between the pedestals

Then

$$A = \frac{P}{2600}$$

$$B = \frac{P}{3000}$$

$$C = \frac{P}{4400}$$

**Cylinders.** The formula commonly used in determining the thickness of boiler shells, circular tanks, and cylinders is

$$t = \frac{p d}{2 f}$$

where

$t$  = thickness of cylinder wall in inches

$p$  = pressure in pounds per square inch

$d$  = diameter of cylinder in inches

$f$  = safe fiber stress which for cast iron is usually taken at 1500 pounds per square inch

For cylinder heads, the following empirical formula may be used in calculating the thickness:

$$T = .00439 d \sqrt{p}$$

where

$T$  = the thickness of the cylinder head in inches

$p$  = boiler pressure in pounds per square inch

$d$  = diameter of stud bolt circle

Cylinder specifications usually call for a close grain metal as hard as can be conveniently worked. The securing of the proper proportions of a cylinder for a locomotive is a matter of great importance in locomotive design. The cylinders must be large enough so that with a maximum steam pressure they can always turn the driving wheels when the locomotive is starting a train. They should not be much greater than this, however, otherwise the pressure on the piston would probably slip the wheels on the rails. The maximum force of the steam in the cylinders should therefore be equal to the adhesion of the wheels to the rails. This may be assumed to be equal to one-fourth of the total weight

on the driving wheels. The maximum mean effective piston pressure in pounds per square inch may be taken to be 85 per cent of the boiler pressure.

As the length of the stroke is usually fixed, by the convenience of arrangement and the diameter of the driving wheels, a determination of the size of the cylinder usually consists in the calculation of its diameter. In order to make this calculation, the diameter of the driving wheels and the weight on them, the boiler pressure, and the stroke of the piston must be known. With this data, the diameter of the cylinder can be calculated as follows:

The relation between the weight on the drivers and the diameter of the cylinder may be expressed by the following equation:

$$W = \frac{.85 d^2 p L}{C D}$$

where

$W$  = the weight in pounds on drivers

$d$  = diameter of cylinders in inches

$p$  = boiler pressure in pounds per square inch

$L$  = stroke of piston in inches

$D$  = diameter of drivers in inches

$C$  = the numerical coefficient of adhesion

From the above equation, the value of  $d$  may be obtained since the coefficient of adhesion  $C$  may be taken as .25. The equation then becomes

$$W = \frac{.85 d^2 p L}{.25 D}$$

from which

$$d = \sqrt{\frac{.25 W D}{.85 p L}}$$

*Example.* What will be the diameter of the cylinders for a locomotive having 196,000 pounds on the drivers, a stroke of 24 inches, drivers 63 inches in diameter, and a working steam pressure of 200 pounds per square inch?

SOLUTION.

$$\begin{aligned} d &= \sqrt{\frac{.25 \times 196000 \times 63}{.85 \times 200 \times 24}} \\ &= 27.5 \text{ inches} \end{aligned}$$

The above formula gives a method of calculating the size of cylinders to be used with a locomotive when the steam pressure, weight on drivers, diameter of drivers, and stroke

are known. This formula is based upon the tractive force of a locomotive or the amount of pull which it is capable of exerting.

The *tractive force* of a locomotive may be defined as being the force exerted in turning its wheels and moving itself with or without a load along the rails. It depends upon the steam pressure, the diameter and stroke of the piston, and the ratio of the weight on the drivers to the total weight of the engine, not including the tender. The formula for the tractive force of a simple engine is

$$T = \frac{.85 p d^2 L}{D}$$

where

$T$  = the tractive force in pounds

$d$  = diameter of cylinders in inches

$L$  = stroke of the piston in inches

$D$  = diameter of the driving wheels in inches

$p$  = boiler pressure in pounds per square inch

When indicator cards are available, the mean effective pressure on the piston in pounds per square inch may be accurately determined and its value  $p_1$ , may be used instead of  $.85 p$ , in which case the formula becomes

$$T = \frac{p_1 d^2 L}{D}$$

Some railroads make a practice of reducing the diameter of the drivers  $D$  by 2 inches in order to allow for worn tires.

In the case of a two-cylinder compound locomotive, the formula for tractive force is

$$T = \frac{.85 p (d_1)^2 L}{1 + \left(\frac{d_1}{d_2}\right)^2 D}$$

where

$D$  = the diameter of the drivers in inches

$d_1$ , = diameter of low-pressure cylinder in inches

$d_2$ , = diameter of high-pressure cylinder in inches

*Train Resistance.* The resistance offered by a train per ton of weight varies with the speed, the kind of car hauled, the condition of the track, journals and bearings, and atmospheric conditions.

Taking the average condition as found upon American railroads, the train resistance is probably best represented by the Engineering News formula

$$R = \frac{S}{4} + 2$$

in which

$R$  = the resistance in pounds per net ton (2000 pounds) of load

$S$  = speed in miles per hour

The force for starting is, however, about 20 pounds per ton which falls to 5 pounds as soon as a low rate of speed is obtained. The resistance due to grades is expressed by the formula

$$R' = 0.38 M$$

in which

$R'$  = the resistance in pounds per net ton of load

$M$  = grade in feet per mile

The resistance due to curves is generally taken at from .5 to .7 pounds per ton per degree of curvature. Taking the latter value and assuming that locomotives on account of their long rigid wheel base produce double the resistance of cars, we have

$R'' = .7 C$  for cars, and

$R'' = 1.4 C$  for locomotives

in which

$R''$  = the resistance in pounds per net ton due to curvature

$C$  = the curvature in degrees

Considerable resistance is offered by wind but this is of such a nature that calculations are extremely difficult to make which would be of any practical value.

The resistances mentioned above do not take into account that due to the acceleration of the train. This may be expressed by the formula

$$R''' = .0132 v^2$$

in which

$v$  = the speed in miles per hour attained in one mile when starting from rest, being uniformly accelerated

$R'''$  = resistance in pounds per net ton due to acceleration

**Locomotive Rating.** Since the locomotive does its work most economically and efficiently when working to its full capacity, it becomes necessary to determine how much it can handle. The determination of the weight of the train which a locomotive can handle is called the *rating*. This weight will vary for the same locomotive under different conditions. The variation is caused by the difference in grade, curvature, temperature conditions of the rail, and the amount of load in the cars. The variation due to the differences of car resistance arising from a variation of the conditions of the journals and lubrication is neglected because of the assumption of a general average of resistance for the whole.

The usual method of rating locomotives at present is that of tonnage. That is to say, a locomotive is rated to handle a train, weighing a certain number of tons, over a division. This is preferred to a given number of loaded or empty cars because of the indefinite variation in the weights of the loads and the cars themselves.

In the determination of a-locomotive rating there are several factors to be considered, namely, the power of the locomotive, adhesion to the rail, resistance of the train including the normal resistance on a level, and that due to grades and curves, value of momentum, effect of empty cars, and the effect of the weather and seasons.

The power of a locomotive and its adhesion to the rails has already been considered. From the formula given, the tractive power can be calculated very closely from data already at hand.

There are three methods in use for obtaining the proper tonnage rating. First, a practical method which consists in trying out each class of engine on each critical or controlling part of the division and continuing the trials until the limit is reached. Second, a more rapid and satisfactory method is to determine the theoretical rating. Third, the most satisfactory method is, first, to determine the theoretical rating and then to check the results by actual trials.

The value of the momentum of a train is a very important element in the determination of the tonnage rating of locomotives on most railroads. In mountainous regions, with long heavy grades, there is little opportunity to take advantage of momentum, while on undulating roads, it may be utilized to the greatest advantage. An approach to a grade at a high velocity when it can be reduced in ascending the same, enables the engine to handle greater loads than would otherwise be possible without such assistance. Hence, stops, crossings, curves, water tanks, etc., will interfere with the make-up of a train if so located as to prevent the use of momentum. It is necessary, therefore, to keep all these points in mind when figuring the rating of a locomotive for handling trains over an undulating division.

The ordinary method of allowing for momentum is to deduct the velocity head from the total ascent and consider the grade easier by that amount.

For example: Suppose that a one per cent grade 5,000 feet long is so situated that trains could approach it at a high speed. The total rise of the grade would be 50 feet but 15 feet of that amount could be overcome by the energy of the train, leaving 35 feet that the train must be raised or lifted by the engine. The grade in which the rise is 35 feet in 5,000 would be a 0.7 per cent grade, so that if the engine could exert sufficient force to

overcome the train resistance and that due to a 0.7 per cent grade, the train could be lifted the remainder of the height by its kinetic energy. In this case, the 5,000 feet of one per cent grade could be replaced by a grade of 0.7 per cent 5,000 feet long, and the effect on the load hauled by the engine would be the same if in the latter case the energy of the train were not taken into account. Since the height to which the kinetic energy raises the train is independent of the length of the grade, its effect becomes far less when the grades are long than when short. Thus, for a one per cent grade 1,000 feet long, the total rise being only 10 feet, the kinetic energy would be more than sufficient to raise the weight of the train up the entire grade leaving only the frictional resistance to be overcome by the engine; whereas if the grade were 50,000 feet in length, or a total rise of 500 feet, the energy of the train would only reduce this rise about 15 feet, leaving a rise of 485 feet or the equivalent of a 0.99 per cent grade to be overcome by the engine, a reduction not worth considering.

It is thus seen that the length of a grade exerts a great influence on the value of the momentum.

Within ordinary limits, the following formula gives very accurate results

$$T = \frac{d^2 L p_1}{D \left( R' + \frac{a}{2.64} \right) \left( 1 - \frac{V^2 - v^2}{.00566 a l \left( 1 + \frac{2.64 R'}{a} \right)} \right)}$$

where

$T$  = number of tons including engine, which can be hauled over a grade with velocities of  $V$  and  $v$

$d$  = diameter of cylinder in inches

$L$  = length of stroke in inches

$p_1$  = mean effective pressure in pounds per square inch

$D$  = diameter of driver in inches.

$R'$  = resistance in pounds per ton on a level track due to friction, air curves, and velocity, which may be taken at 8 pounds per ton

$a$  = grade in feet per mile

$l$  = length of grade in feet

$V$  = velocity in miles per hour at foot of grade

$v$  = velocity in miles per hour at top of grade

Thus, with an engine having cylinders 17 inches in diameter, a stroke of 24 inches, driving wheels 62 inches in diameter, and running at a velocity of 30 miles per hour, the formula gave a rating of 738 tons. On actual tests, it was possible to handle 734 tons with a speed of 10 miles an hour at the top of the grade.

The effect of empty cars is to reduce the total tonnage of the train below what could be handled if they were all loaded. The resistance of empty cars when on a straight and level track varies from 30 to 50 per cent more per ton of weight than loaded cars.



In using the formula given above, loaded cars are assumed. For empty cars, 40 per cent should be added. That is to say, if a train is composed of empty and loaded cars and is found to have a certain resistance, 40 per cent should be added to the portion of resistance due to the empty cars.

There is considerable difference of opinion regarding the allowance which should be made for the conditions of weather, etc. The following is a fair allowance which has been found to give satisfactory results in practice: Seven per cent reduction for frosty or wet rails; fifteen per cent reduction for from freezing to zero temperature; and twenty per cent reduction for from zero to twenty degrees below. The use of pushing or helping engines over the most difficult grades of an undulating track will increase the train load and thus reduce the cost of transportation.

## LOCOMOTIVE APPLIANCES

In order to enable the engineer to operate and control a locomotive successfully and economically a certain number of fittings on the locomotive are necessary. These fittings consist chiefly of the safety valves, whistle, steam gauge, lubricator, water gauges, blower, throttle valve, injector, air brake, and signal apparatus.

**Safety Valves.** The universal practice at present is to use at least two safety valves of the pop type upon every locomotive boiler. On small locomotives where clearances will permit, the safety valves are placed in the dome cap. On large locomotives where the available height of the dome is limited, the safety valves are usually placed on a separate turret. When limiting heights will not permit the use of turrets, the safety valves may be screwed directly into the roof of the boiler.

The construction of a good safety valve is such that when it is raised, the area for the escape of steam is sufficient to allow it to escape as rapidly as it is formed, and that as soon as the pressure has fallen a pre-determined amount, it will close.

It should be so designed that it can neither be tampered with nor get out of order. It must act promptly and efficiently and not be affected by the motion of the locomotive. These conditions are all fulfilled in the type of valve shown in section in [Fig. 91](#). In this design, the valve *a* rests on the seat *b b* and is held down by a spindle *c*, the lower end of which rests on the bottom of a hole in the valve *a*. A helical spring *d* tests on a collar on the spindle. The pressure on the spindle is regulated by screwing the collar *e* up or down. The valve seat *b b* may be rounded or straight. Outside of the valve seat there is a projection *f*, beneath which a groove *g* is cut in the casing. When the valve lifts, this groove is filled with steam which presses against that portion of the valve outside of the seat, and, by thus increasing the effective area of the valve, causes it to rise higher and to remain open longer than it otherwise would without this projection. The adjustment of the valve is usually made so that after opening, it will permit steam to escape until the pressure in the boiler is about 4 pounds below the normal pressure. The steam escaping through the small holes *h*, is muffled, thus avoiding great annoyance.

Another form of safety valve which is being largely used is that shown in [Fig. 92](#). The principle of its operation is the same as that just described. It is said to be very quiet and yet gives effective relief. It is being adopted by several railroads.

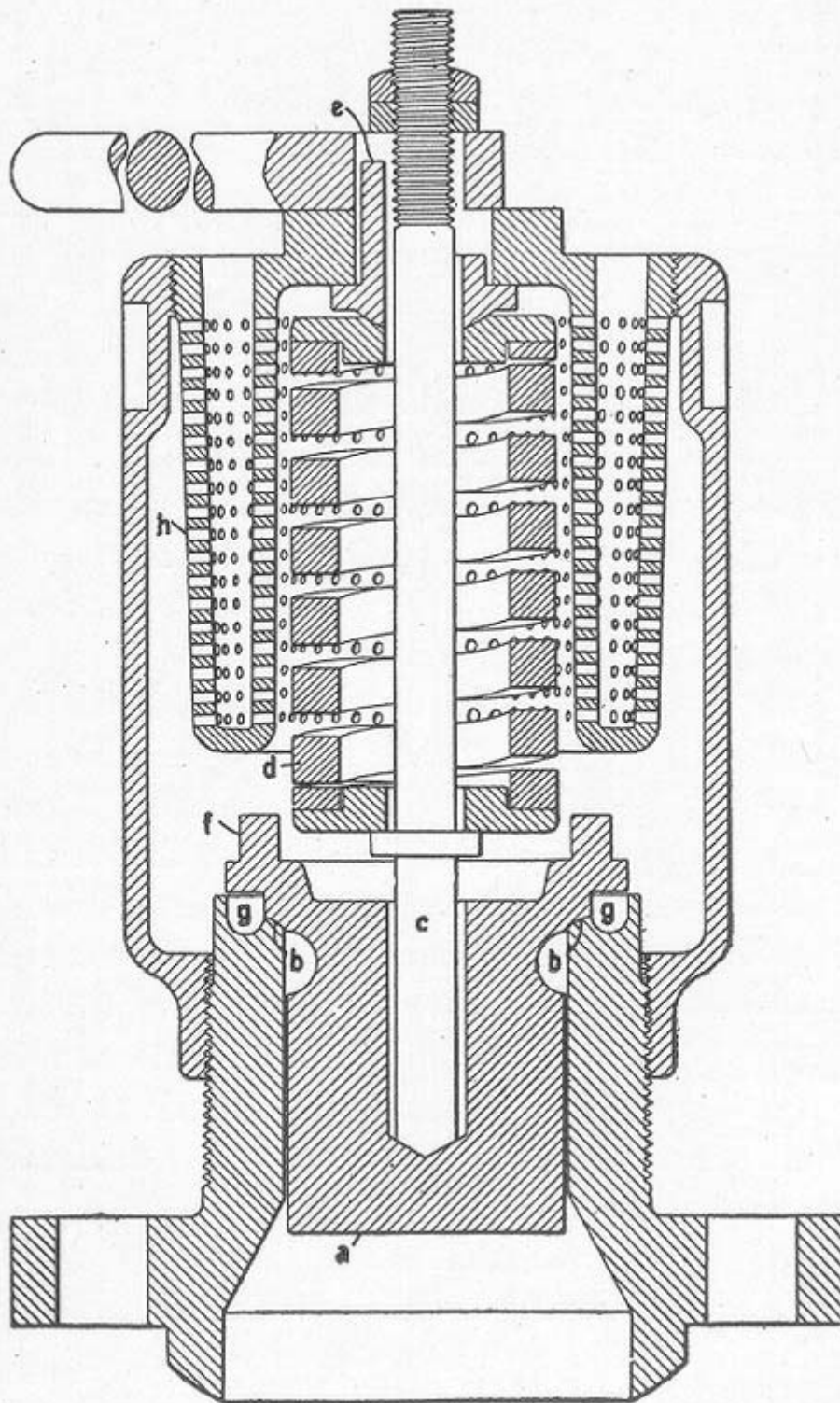

Fig. 91. Section of Safety Valve.

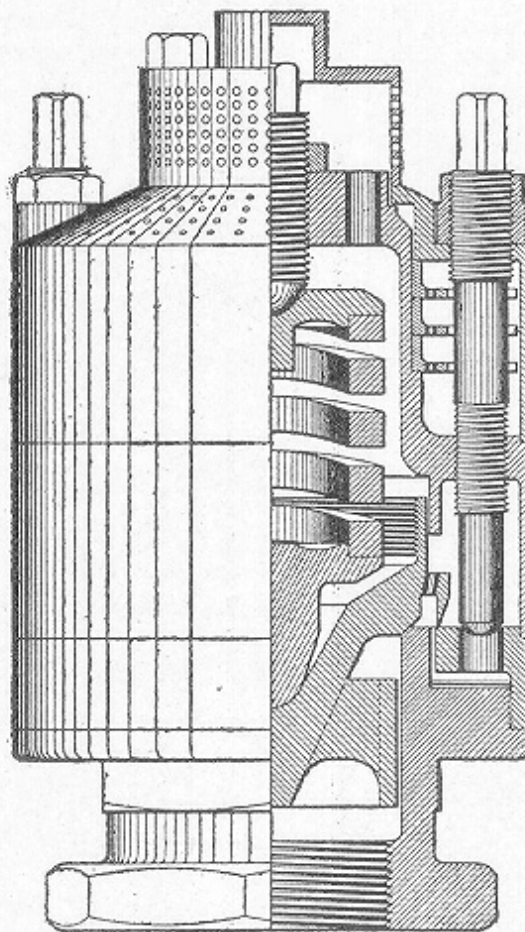

Fig. 92. Another Form of Safety Valve.

**The Injector.** The injector may be defined as an apparatus for forcing water into a steam boiler in which a jet of steam imparts its energy to the water and thus forces it into the boiler against boiler pressure. Injectors are now universally employed for delivering the feed water to the boiler. Two injectors are always used, either one of which should have a capacity sufficient to supply the boiler with water under ordinary working conditions. They are located one on either side of the boiler. Injectors may be classified as *lifting* and *non-lifting*, the former being most commonly used. The lifting injector is placed above the high water line in the tank, therefore in forcing water into the boiler, it lifts the water through a height of a few feet. The non-lifting injector is placed below the bottom of the water tank, hence the water flows to the injector, by reason of gravitation.

There are a great many different injectors on the market. All work upon the same general principle, differing only in the details of construction. One type only will be described, namely, the Sellers injector illustrated in [Fig. 93](#).

*Sellers Injector.* To operate this injector, the method of procedure is as follows: Draw starting lever, 33, slowly. If the water supply is hot, draw the lever about one inch and after the water is lifted, draw the lever out the entire distance. The cam lever, 34, must be in the position shown. To stop the injector, push the starting lever in. To regulate the amount of flow of water after the injector has been started, adjust the regulating handle, 41.

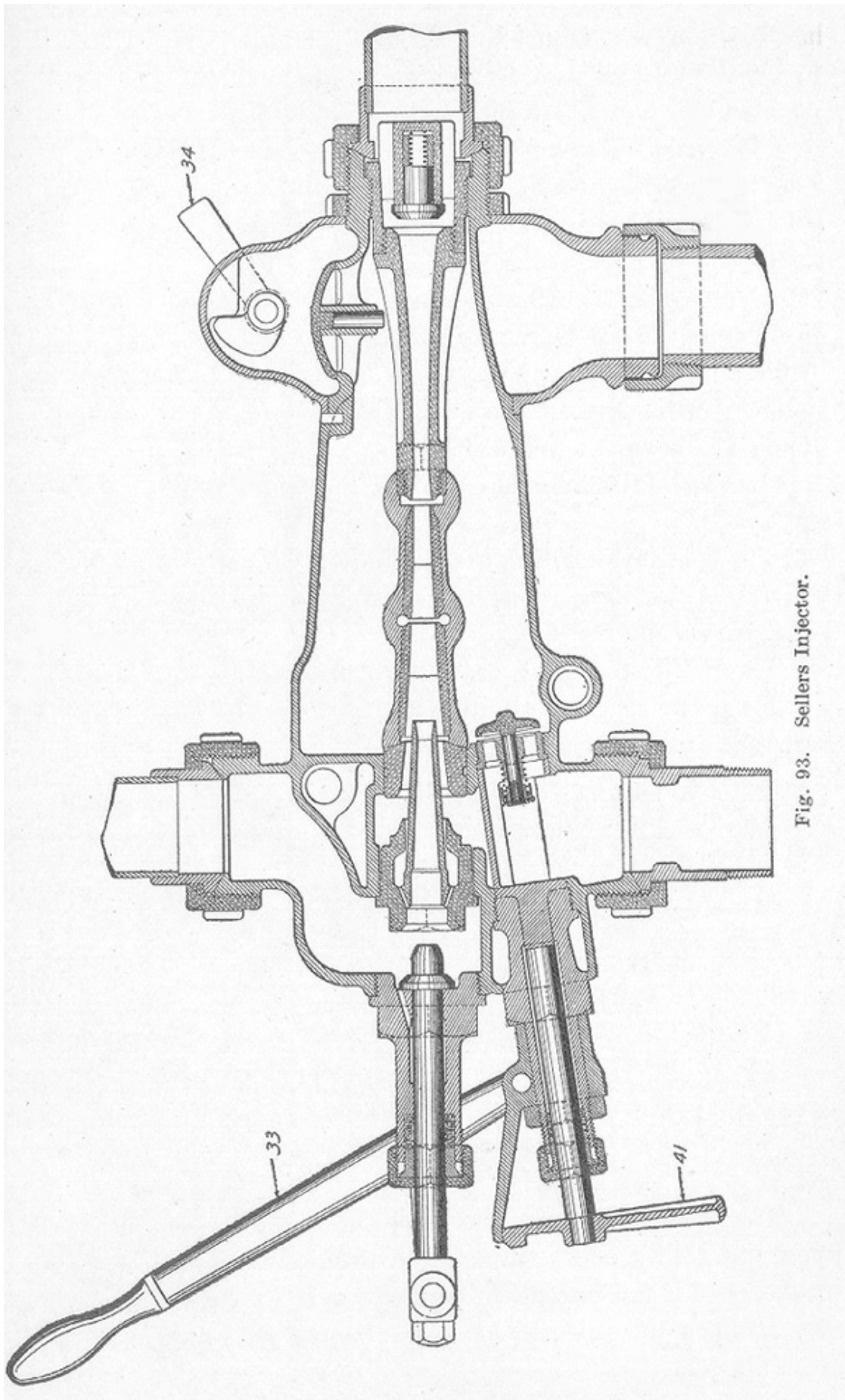

Fig. 93. Sellers Injector.

If it is desired to use the injector as a heater, place the cam lever, 34, in the rear position and pull the starting lever slowly.

The injector is not a sensitive instrument but requires care to keep it in working condition. It should be securely connected to the boiler in easy reach of the engineer. All joints must be perfectly tight to insure good working conditions. All pipes, hose connections, valves, and strainers must be free from foreign matter. Most failures of injectors are due largely to the presence of dirt, cotton, waste, etc., in the strainers. It is not possible to mention in detail all circumstances which produce injector failures but the complaints commonly heard are as follows:

1. The injector refuses to lift the water promptly, or not at all.
2. The injector lifts the water but refuses to force it into the boiler. It may force a part of the water into the boiler, the remainder being lost in the overflow.

Unless these failures are due to the wearing out of the nozzles which may be renewed at any time, they may be largely avoided by keeping in mind the following points:

All pipes, especially iron ones, should be carefully blown out with steam before the injector is attached, the scale being loosened by tapping the pipes with a hammer.

All valves should be kept tight and all spindles kept tightly packed. When a pipe is attached to the overflow, it should be the size called for by the manufacturer.

The suction pipe must be absolutely tight since any air leak reduces the capacity of the injector.

The delivery pipe and boiler check valve must be of ample dimensions.

The suction pipes, hose, and tank valve connections must be of ample size and the hose free from sharp kinks and bends.

The strainer should be large enough to give an ample supply of water even if a number of the holes are choked.

The injector is one of the most important boiler appliances, for upon the ability of the injector to promptly supply the necessary water depends the movement of trains. It is, therefore, very necessary to keep the injector in perfect repair by following the hints given above.

**The Whistle.** The whistle is used for signaling purposes and consists of a thin circular bell, [Fig. 94](#), closed at the top and sharp at the lower edge. Steam is allowed to escape from a narrow circular orifice directly beneath the edge of the bell. A part of the escaping steam enters the interior of the bell and sets up vibrations therein. The more rapid these vibrations, the higher the tone of the whistle. The tone is affected by the size of the bell and the pressure of the steam. The larger the bell, the lower will be the tone. The higher the steam pressure, the higher the tone. In order to avoid the shrill noise of the common whistle, chime whistles are commonly used, one type of which is illustrated in [Fig. 94](#). In this illustration the bell is divided into three compartments of such proportions that the tones harmonize and give an agreeable chord.



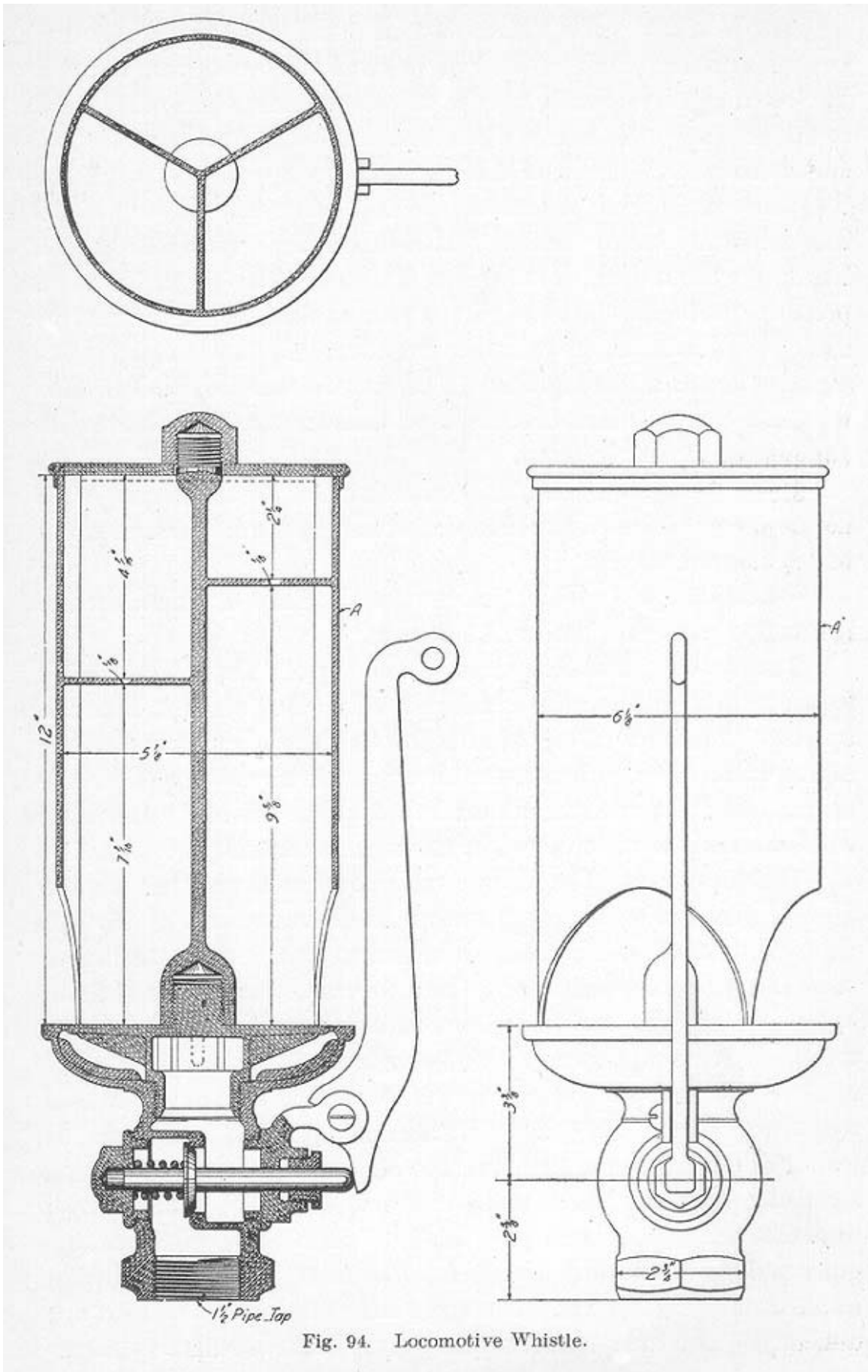

Fig. 94. Locomotive Whistle.

**Steam Gauges.** The usual construction of the steam gauge will not be presented here but reference is made to the instruction paper on "Boiler Accessories."

**Water Gauges.** Water gauges are also fully explained in the instruction paper on "Boiler Accessories."

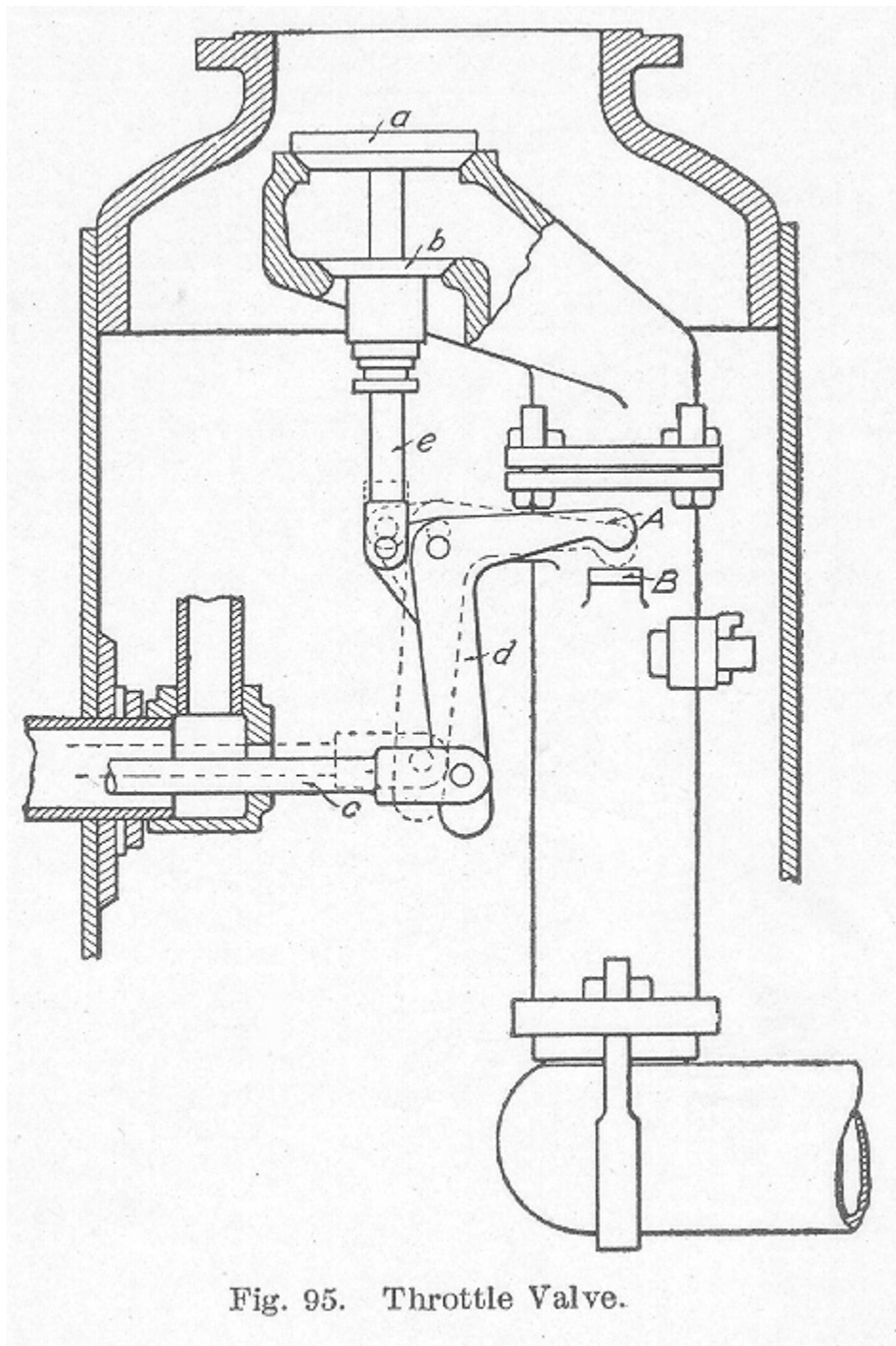

Fig. 95. Throttle Valve.

**The Blower.** The blower consists merely of a steam pipe leading from and fitted with a valve in the cab to the stack where it is turned upward. The end of this pipe is formed into a nozzle. The escaping steam gives motion to the air exactly as already explained for the exhaust and thus induces a draft through the fire-box. It is used when the fire is to be forced while the engine is standing.

**Throttle Valve.** The throttle valve now in universal use is some form of a double-seated poppet valve, as illustrated in [Fig. 95](#). In this type, two valves *a* and *b* are attached to a single stem, the upper valve being slightly the larger. The lower valve *b* is of such a diameter that it will just pass through the seat of the valve *a*. The steam, therefore, exerts a pressure on the lower face of *b* and the upper face of *a*. As the area of *a* is the greater, the resultant tendency is to hold the valve closed. The valve is, therefore, partially balanced. It will be difficult to open large throttle valves such as are now used on locomotives carrying high steam pressures, with the ordinary direct form of leverage. In such cases, it will be necessary to give a strong, quick jerk to the throttle lever before the valve can be moved from its seat. The arrangement of leverage shown in [Fig. 95](#) obviates this difficulty. The rod *c* connects with a lever in the cab and co-axially connects its movement to the bell crank *d*, whence it is carried by the stem *e* to the valve. The pivot of the bell crank is provided with a slotted hole. At the start, the length of the short arm is about 2¼ inches while the long arm is about 9½ inches. After the valve has been lifted from its seat and is free from excess pressure on *a*, the projecting arm *A* on the back of the bell crank comes in contact with the bracket *B* on the side of the throttle pipe and the bell crank takes the position shown by the dotted lines in the figure. The end of the projecting arm *A* then becomes the pivot and the length of the short arm of the lever is changed to 9½ inches and that of the long arm to about 11½ inches.

**Dry Pipe.** The dry pipe connects with the throttle valve in the steam dome and extends from the dome to the front flue sheet, terminating in the **T**, which supplies steam to the steam pipes. It is evident, therefore, that the dry pipe must be of such capacity that it will supply both cylinders with a sufficient amount of steam. The following sizes are usually used:

**TABLE XIX**  
**Dry Pipe Sizes**

Diameter of Cylinder in Inches	Diameter of Dry-Pipe in Inches
14 - 17	5
17 - 19	6
19 - 21	7
21	8

**Lubricator.** The lubricator, one of the most essential locomotive appliances, is usually supported by a bracket from the back head of the boiler in convenient reach of the engineer. It may be a two-, three-, or four-sight feed lubricator as the case demands, the number of sight feeds indicating the number of lubricating pipes supplied by the lubricator. For instance, a two-sight feed lubricator has two pipes, one leading to each steam chest. A triple-sight feed is used to supply oil to both steam chests and also to the cylinder of the air pump. In using superheaters, it has been found necessary to oil the cylinders as well as the valves, hence the need of the four-sight feed lubricator. [Fig. 96](#) shows sections of a well-known make of a triple-sight feed lubricator. The names of the parts are as follows:

- |                                |                            |
|--------------------------------|----------------------------|
| 1. CONDENSER                   | 15. REGULATING VALVES      |
| 2. FILLING PLUG                | 16. TOP CONNECTION         |
| 3. HAND OILER                  | 17. EQUALIZING PIPE        |
| 4. CHOKE PLUG or REDUCING PLUG | 18. OIL PIPE               |
| 5. TAILPIECE                   | 19. WATER PIPE             |
| 6. DELIVERY NUT                | 20. SIGHT FEED DRAIN VALVE |
| 7. WATER VALVE                 | 21. EXTRA GLASS AND CASING |
| 8. STUD NUT                    | 22. CLEANING PLUG          |
| 9. SIGHT FEED GLASS AND CASING | 23. BODY PLUG              |
| 9a. FEED NOZZLE                | 24. OIL PIPE PLUG          |
| 11. BODY                       | 28. GAUGE GLASS BRACKET    |
| 13. GAUGE GLASS AND CASING     | 29. CLEANING PLUG          |
| 14. WASTE COCK                 | 30. GAUGE GLASS CAP        |

The lubricator is fastened to the boiler bracket by means of the stud nut, 8. In brief, the operation of the lubricator, as illustrated in [Fig. 96](#), is as follows:

Steam is admitted to the condensing chamber, 1, through the boiler connection, 16. The steam condenses in the condenser and passes through the equalizing pipe to the bottom of the oil reservoir. The lubricator is filled at the filling plug, 2. As the condensed steam fills up the lubricator, the oil level is raised until the oil passes through the tubes, 18, to the regulating valve, 15, from whence it is permitted to pass drop by drop through the sight feed glass, 9, to the different conveying pipes. To fill the lubricator, first be sure that the steam valve is closed, then remove the filling plug and pour in the necessary amount of oil. After the filling plug has been replaced, open the steam valve slowly and let it remain open. After this, regulate the flow of oil by means of the regulating valves, 15.

**Air Brake and Signal Equipment.** The air brake and signal equipment are fully explained in the instruction book on the "Air Brake" and will not be presented.

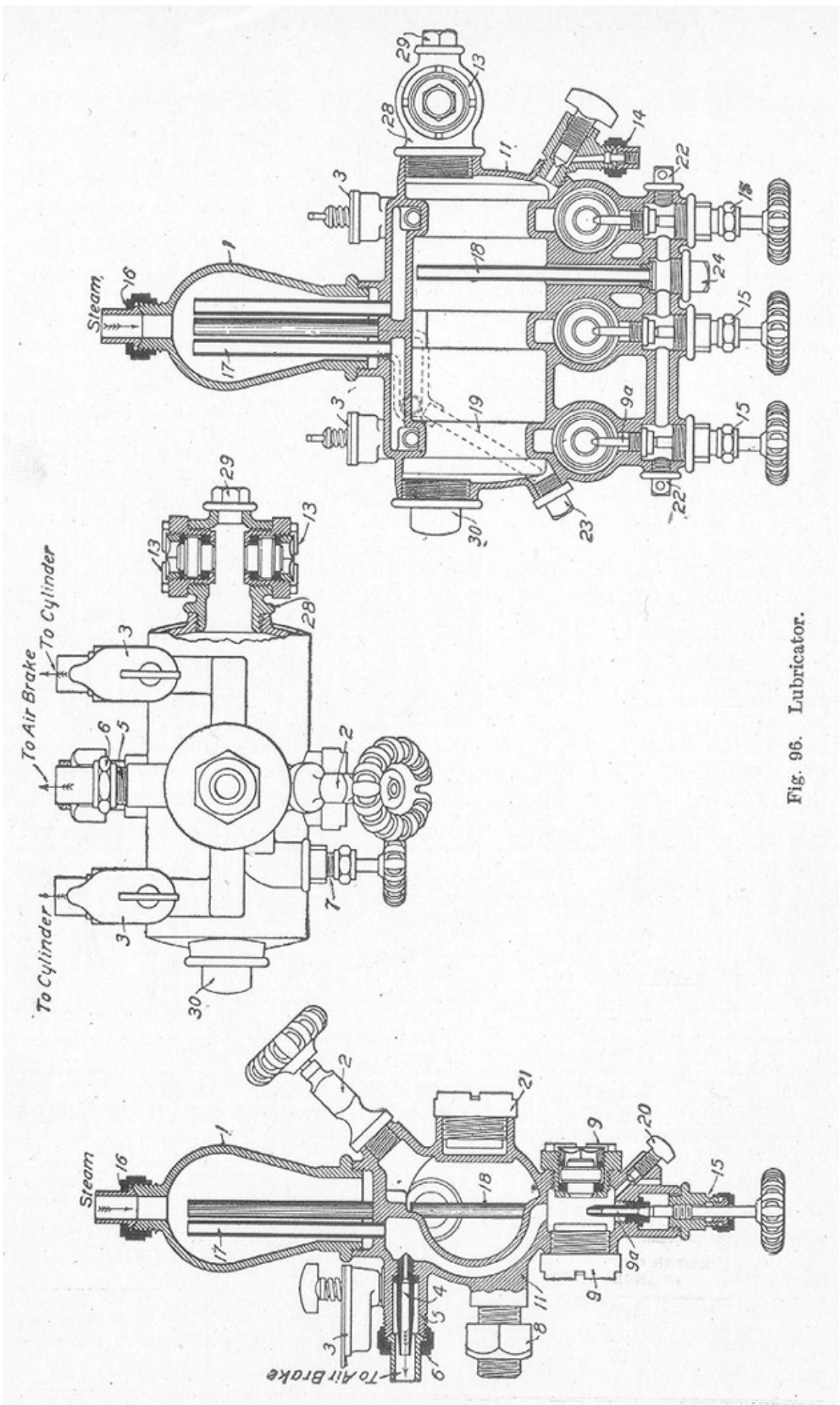

Fig. 96. Lubricator.

## RAILWAY SIGNALING

Railway signaling is a very important subject and one to which a great deal of attention has been directed in recent years; it is by no means a new subject, however, nor has its development been rapid. It early became evident that signals are necessary in governing the movement of trains, so we find that as the traffic and speed of trains increased, the demand for improvements in signaling likewise increased.

Although there are a great many kinds of signals on the market, they may all be classed under four general types, namely, *audible*, *movable*, *train*, and *fixed signals*. The audible signal is well known as the bell, whistle, and torpedo.

**Whistle Signals.** One long blast of the whistle is the signal for approaching stations, railroad crossings, and junctions. (Thus \_\_\_\_.)

One short blast of the whistle is the signal to apply the brakes to stop. (Thus \_\_.)

Two long blasts of the whistle is the signal to release the brakes. (Thus \_\_\_\_ \_\_\_\_.)

Two short blasts of the whistle is an answer to any signal unless otherwise specified. (Thus \_\_ \_\_.)

Three long blasts of the whistle to be repeated until answered is the signal that the train has parted. (Thus \_\_\_\_ \_\_\_\_ \_\_\_\_.)

Three short blasts of the whistle when the train is standing, to be repeated until answered, is a signal that the train will back. (Thus \_\_ \_\_ \_\_.)

Four long blasts of the whistle is a signal to call in the flagman from the west or south. (Thus \_\_\_\_ \_\_\_\_ \_\_\_\_ \_\_\_\_.)

Four long, followed by one short blast of the whistle, is the signal to call in the flagman from the east or north. (Thus \_\_\_\_ \_\_\_\_ \_\_\_\_ \_\_.)

Four short blasts of the whistle is the engineman's call for signals from switch tenders, watchmen, trainmen, and others. (Thus \_\_ \_\_ \_\_ \_\_.)

One long and three short blasts of the whistle is a signal to the flagman to go back and protect the rear of the train. (Thus \_\_\_\_ \_\_ \_\_ \_\_.)

One long, followed by two short blasts of the whistle, is the signal to be given by trains when displaying signals for a following train to call the attention of trains of the same or inferior class to the signals displayed. (Thus \_\_\_\_ \_\_ \_\_.)

Two long followed by two short blasts of the whistle is the signal for approaching road crossings at grade. (Thus \_\_\_\_ \_\_\_\_ \_\_ \_\_.)

A succession of short blasts of the whistle is an alarm for persons or cattle on the track and calls the attention of trainmen to the danger ahead.



**Bell Cord Signals.** One short pull of the signal cord when the train is standing is the signal to start.

Two pulls of the signal cord when the train is running is the signal to stop at once.

Two pulls of the signal cord when the train is standing is the signal to call in the flagman.

Three pulls of the signal cord when the train is running is the signal to stop at the next station.

Three pulls of the signal cord when the train is standing is the signal to back the train.

Four pulls of the signal cord when the train is running is the signal to reduce the speed.

When one blast of the signal whistle is heard while a train is running, the engineer must immediately ascertain if the train has parted, and, if so, take great precaution to prevent the two parts of the train from coming together in a collision.

**Movable Signals.** Movable signals are used to govern the movement of trains in switching and other service where demanded. They are made with flags, lanterns, torpedoes, fusees, and by hand. The following signals have been adopted as a standard code by the American Railway Association:

Flags of the proper color must be used by day and lamps of the proper color by night or whenever from fog or other cause, the day signals cannot be clearly seen.

*Red* signifies danger and is a signal to stop.  
*Green* signifies caution and is a signal to go slowly.  
*White* signifies safety and is a signal to continue.  
*Green* and *white* is a signal to be used to stop trains at flag stations for passengers or freight.

*Blue* is a signal to be used by car inspectors and repairers and signifies that the train or cars so protected must not be moved.

An explosive cap or torpedo placed on the top of the rail is a signal to be used in addition to the regular signals.

The explosion of one torpedo is a signal to stop immediately. The explosion of two torpedoes is a signal to reduce speed immediately and look out for danger signals.

A fusee is an extra danger signal to be lighted and placed on a track at night in case of accident and emergency.

A train finding a fusee burning on the track must come to stop and not proceed until it has burned out. A flag or a lamp swinging across the track, a hat or any object waved violently by any person on the track, signifies danger and is a signal to stop.

The hand or lamp raised and lowered vertically is a signal to move ahead. [Fig. 97.](#)

The hand or lamp swung across the track is a signal to stop, [Fig. 98](#).

The hand or lamp swung vertically in a circle across the track when the train is standing is a signal to move back. [Fig. 99](#).

The hand or lamp swung vertically in a circle at arm's length across the track when the train is running is a signal that the train has parted. [Fig. 100](#).

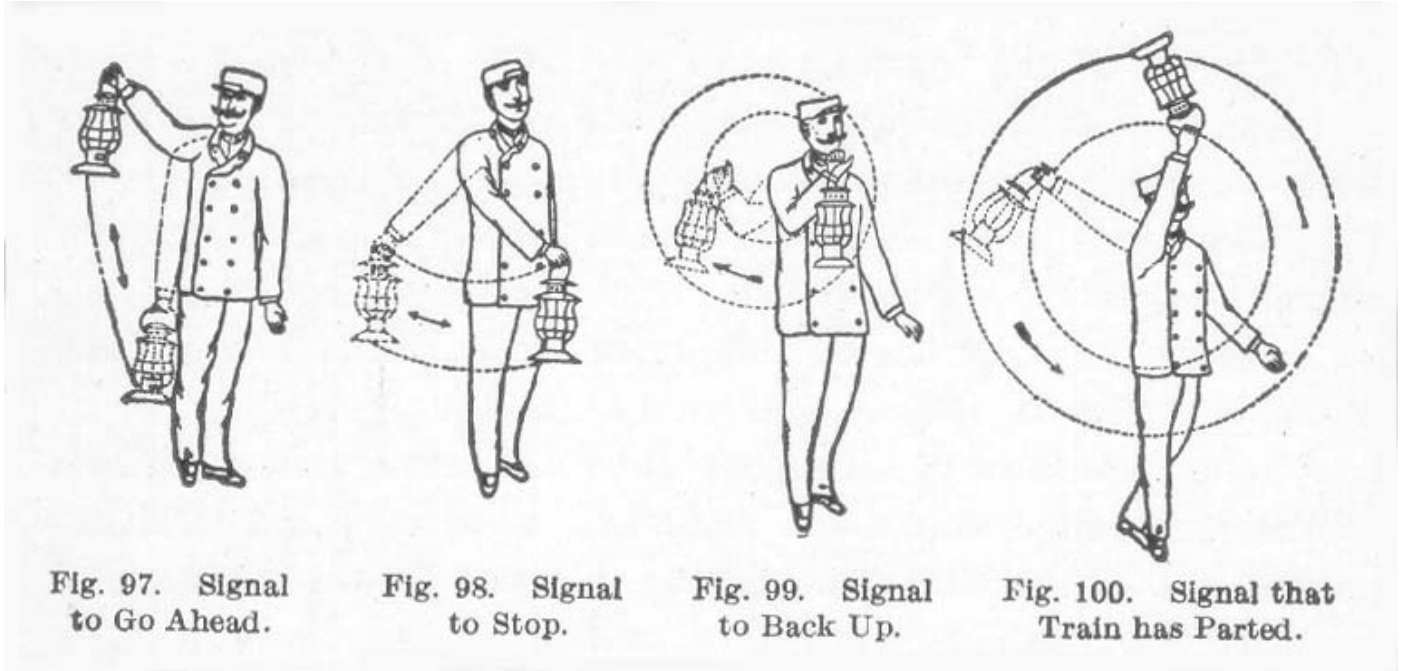

**Train Signals.** Each train while running must display two green flags by day. [Fig. 101](#), and two green lights by night, one on each side of the rear of the train, as makers to indicate the rear of the train.

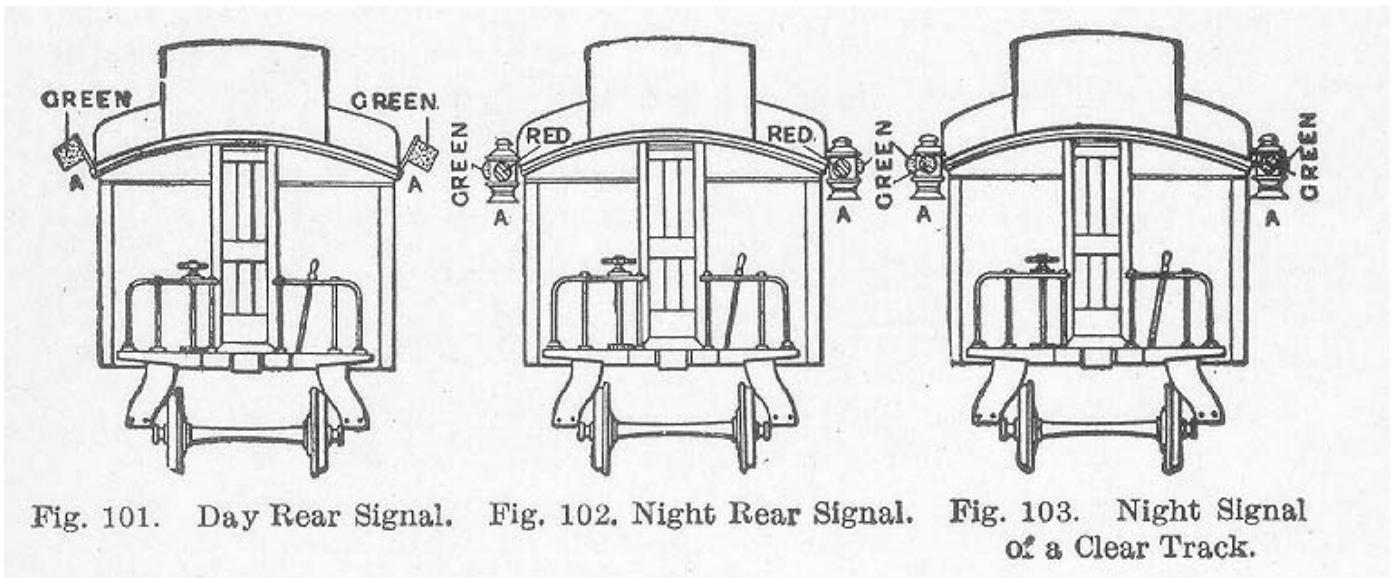

Each train running after sunset or when obscured by fog or other cause, must display the head light in front and two or more red lights in the rear, [Fig. 102](#). Yard engines must

display two green lights instead of red except when provided with a head light on both front and rear.

When a train pulls out to pass or meet another train the red lights must be removed and green lights displayed as soon as the track is clear. [Fig. 103](#), but the red lights must again be displayed before returning to its own track.

Head lights on engines, when on side tracks, must be covered, as soon as the track is clear and the train has stopped and also when standing at the end of a double track.

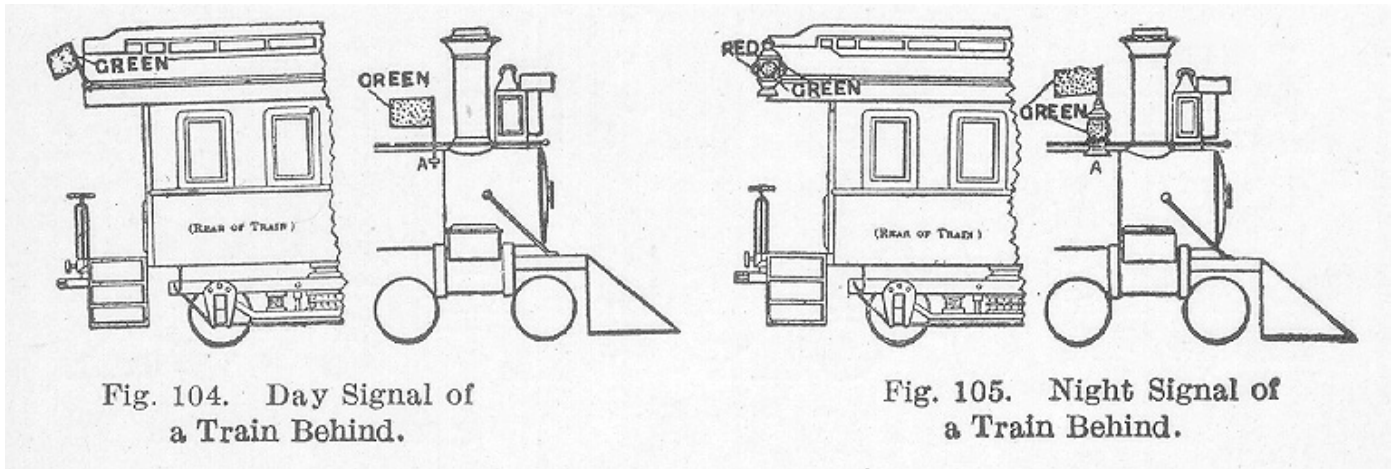

Two green flags by day and night, [Fig. 104](#), and in addition two green lights by night, [Fig. 105](#), displayed in places provided for that purpose on the front of an engine denote that the train is followed by another train running on the same schedule and entitled to the same time table rights as the train carrying the signals.

An application of the above rules to locomotives running backward are shown in [Figs. 106, 107, and 108](#).

[Fig. 106](#) shows the arrangement of flags when a locomotive is running backward by day without cars, or pushing cars and carrying signals for a following train. There are two green flags, one at *A* and one at *B*, on each side. The green flag at *A* is a classification signal and that at *B* is the marker denoting the rear of the train.

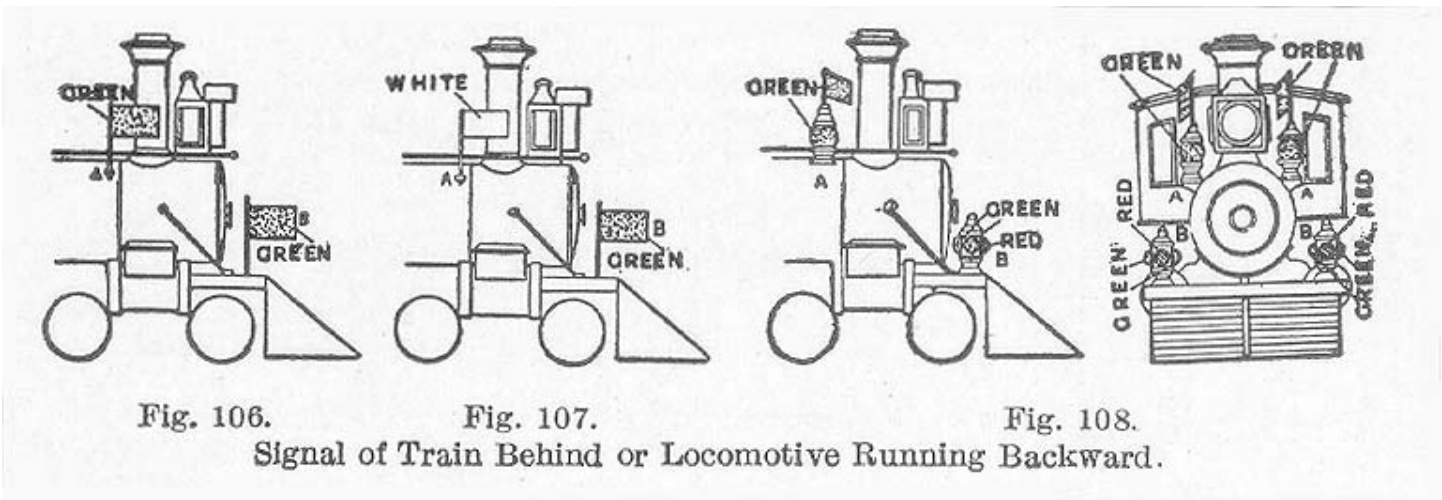

Two white flags by day and night. [Fig. 109](#), and in addition two white lights by night. [Fig. 110](#), displayed in places provided for that purpose on the front of an engine, denote that the train is an extra. These signals must be displayed by all extra trains but not by yard engines.

[Fig. 107](#) shows the arrangement of flags on a locomotive which is running backward by day without cars or pushing cars and running extra. There is a white flag at *A* and a green one at *B*. The white flag is a classification signal and the green flag is the marker denoting the rear of the train.

[Fig. 108](#) shows the arrangement of flags and lights on a locomotive which is running backward by night without cars or pushing cars and carrying signals for a following train. There is a green flag and light at *A* and a combination light at *B*. The green light and flag at *A* serve as a classification signal. The combination light at *B* is a marker showing green on the side and the direction in which the engine is moving and red in the opposite direction.

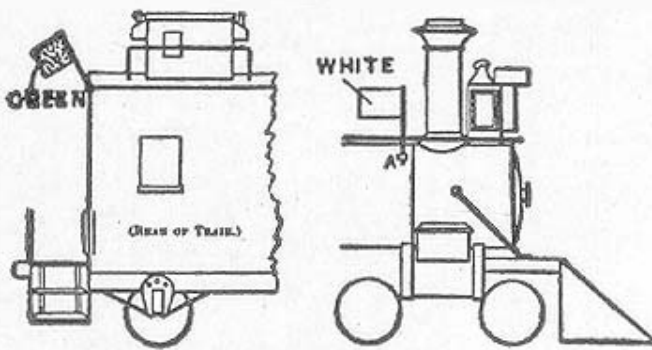

Fig. 109. Day Signal on Extra Train.

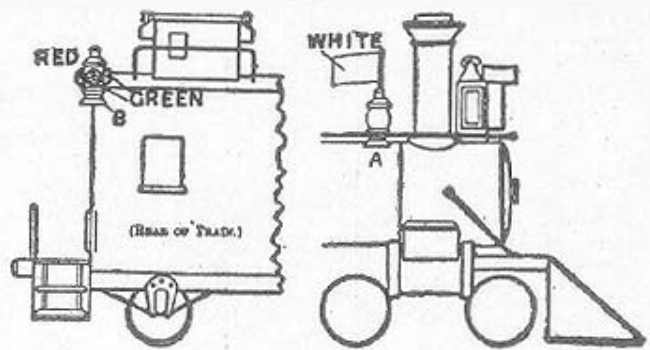

Fig. 110. Night Signal on Extra Train.

[Fig. 110](#) shows the arrangement of flags and lights on a train running forward by night and running extra. There is a white flag and white light at *A* as a classification signal. At *B* there is a combination light. This combination light shows green to the sides and front of the train and red to the rear.

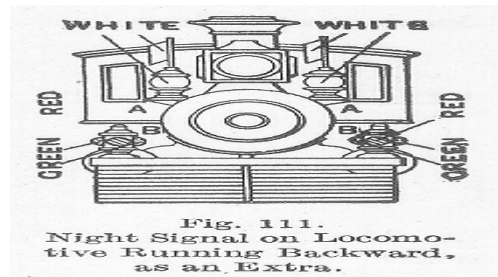

Fig. 111. Night Signal on Locomotive Running Backward, as an Extra.

[Fig. 111](#) shows the arrangement of flags and lights on a locomotive running backward by night without cars or pushing cars and running extra. There are white flags and white lights at *A* as classification signals. At *B B* there are combination lights showing green on the sides and the direction in which the engine is running, and red in the opposite direction. The combination lights serve as markers.



Fig. 112 shows the arrangement of green marker flags on the rear of the tender of a locomotive which is moving forward by day without cars.

Fig. 113 shows the arrangement of combination lights used as markers on the rear of the tender of a locomotive which is running forward at night without cars. The combination light shows green at the sides and front and red at the back.

Fig. 114 shows the arrangement of lights on the rear of the tender of a locomotive which is running backward by night. There is a single white light at *A*.

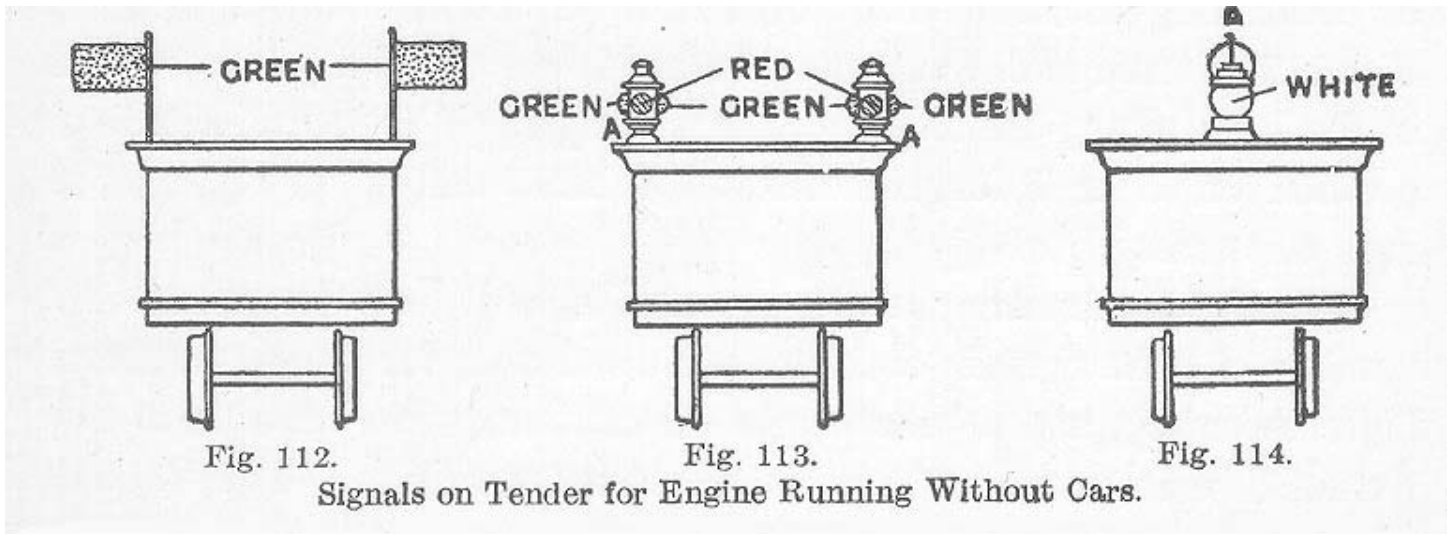
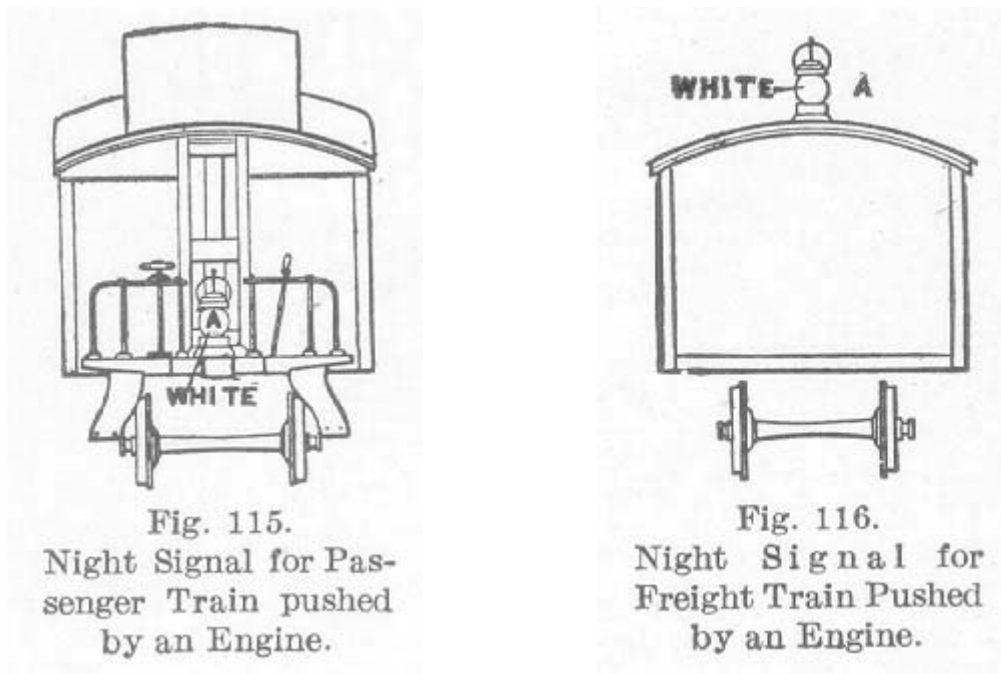

Fig. 115 shows the arrangement of lights on a passenger train which is being pushed by an engine at night. There is a white light at *A* on the front of the leading truck.

Fig. 116 shows the arrangement of lights on a freight train which is being pushed by an engine at night. There is a single white light at *A*.



**Fixed Signals.** Fixed signals consist in the use of posts or towers fixed at definite places and intervals having attached to them a system of rods, levers, and bell cranks to properly operate the arms or semaphores. The target is one form of fixed signal.

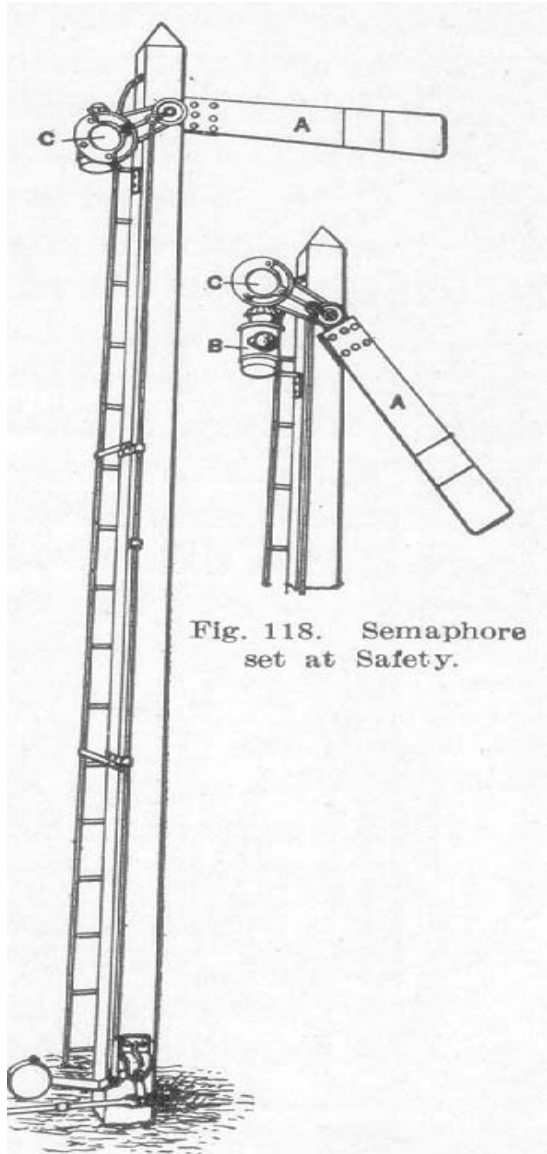

Fig. 118. Semaphore set at Safety.

Fig. 117. Semaphore Set at Danger Signal.

*Targets* are used to indicate, by form or color or both, the position of a switch. A target usually consists of two plates of thin metal at right angles to each other attached to the switch staff. The setting of the switch from the main line to a siding, for example, turns the staff through a quarter revolution thus exposing one or the other of the disks to view along the track. The disks or targets are usually painted red and white, respectively. When the red signal is exposed, the switch is set to lead off to the siding. When the white one is exposed, the switch is closed and the main line is clear. At night, a red and green or red and white light shows in place of the target.

The *semaphore* may now be considered as the standard method of controlling the movement of trains. It consists of an arm *A*, Fig. 117, pivoted at one end and fastened to the top of a post. When in the horizontal position, it indicates danger. When dropped to a position of 65 or 70 degrees below the horizontal, as in Fig. 118, it indicates safety.

At night, the semaphore is replaced by a light. There are two systems of light signals; one is to use a red light for danger, a green light for safety, and a yellow light for caution. The other is to use red for danger, white for safety, and green for caution. The method of operation is to have a lantern *B*, Fig. 118, attached to the left-hand side of the signal post in such a position that when the semaphore arm is in the horizontal position, the spectacle glass *C* will intervene between the approaching engine and the lantern as in Fig. 117. This spectacle glass is red. Where green is to be shown with a semaphore in the position shown in Fig. 118, the spectacle frame is double, *aa* in Fig. 119, the upper glass being red and the lower green.



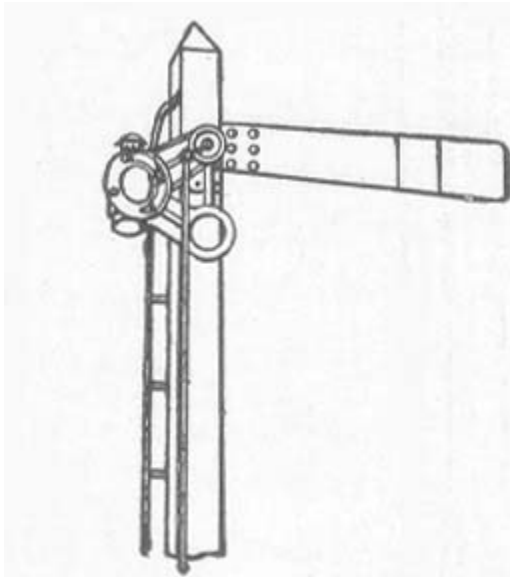

Fig. 119. Home Semaphore Signal.

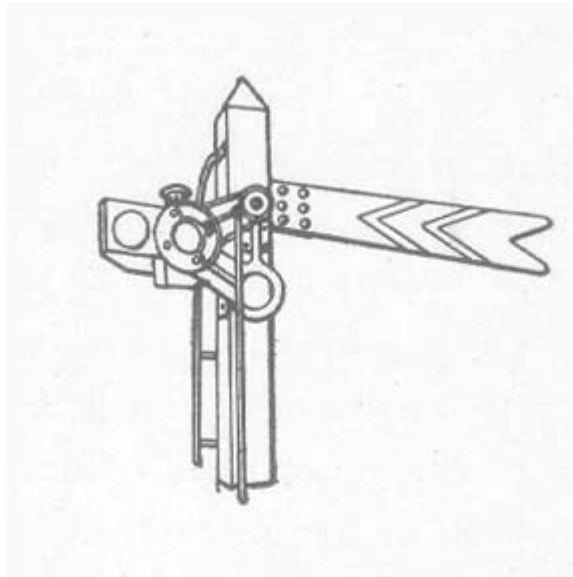

Fig. 120. Distance Semaphore Signal.

Semaphore arms are of two shapes, square at the ends as in [Figs. 117, 118, and 119](#), and with a notched end, as in [Fig. 120](#). The square ended semaphore is used for what is known as the *home* and *advanced signals*, and the notched end for *distance signals*. Semaphores are set so as to be pivoted at the left-hand end as viewed from an approaching train. The arm itself extends out to the right.

The use of home, distance, and advanced signals is as follows: The railroad is divided into blocks at each end of which a home signal is located. When the home signal is in a horizontal position or danger position, it signifies that the track between it and the next one in advance is obstructed and that the train must stop at that point.

The distance signal is placed at a considerable distance in front of the home signal, usually from 1,200 to 2,000 feet, and serves to notify the engineer of the position of the home signal. Thus, if when he passes a distance signal, the engineer sees it to be in a horizontal position, he knows that the home signal is in the danger position also and that he must be prepared to stop at that point unless it be dropped to safety in the meantime. The distance signal should show the cautionary light signal at night.

The advanced signal is used as a supplementary home signal. It is frequently desirable, especially at stations, to permit a train to pass a home signal at danger in order that it may make a station stop and remain there until the line is clear. An arrangement of block signals is shown in [Fig. 121](#). There are three home signals *A, B, and C* on the west bound track, the distance between them being the length of the block. This distance may vary from 1,000 feet to several miles. *D, E, and F* are the corresponding home signals for the east bound track. The distance signals *G, H, I, and K* protect the home signals *B, C, E, and F*; *L* is the advanced signal at the station *M* for the home signal *B*. Thus, a train scheduled to stop at *M* will be allowed to run past the home signal at *B* when it is at danger and stop in front of the advanced signal *L*. When *L* is lowered to safety, the train can move on.

The signals of the block are usually interlocked, that is, one signal cannot be moved to danger or safety until others have been moved. The signals of two succeeding stations are also interlocked, usually electrically.

**Block System.** The term *block* as used above applies to a certain length of track each end of which is protected by means of a distance and home signal. The length of a block varies through wide limits depending upon the nature of the country, amount of traffic, and speed of trains. The heavier the traffic, the more trains there are to be run, so it is desirable to run the trains as close together as possible. Hence, the blocks should be as short as safety will permit. On the other hand, as the speed of the train increases, the time required to pass over a given distance is diminished, hence the length of a block may be increased. The length of the block differs for single-, double-, and four-track roads. Ordinarily the blocks are from ten to twelve miles long. There are a number of different kinds of block systems named as follows, according to the way in which they are operated: the *staff*, *controlled manual*, *automatic*, and *telegraph* systems. All of these systems are similar in their principle of operation, differing only in the means used in securing the desired results. For instance, the controlled manual is operated by a tower man but the mechanism is partly automatic so that he cannot throw his signals until released by mechanism at the other end of the block which electrically locks his signals.

The working of the lock and block system between two stations *A* and *B*, [Fig. 121](#), is as follows: When a train approaches *A*, the operator pulls his signal to clear, provided there is no other train in the block. As the train passes the signal and over a short section of insulated track, the wheels short circuit the track which carries an electric current. This action operates electrical apparatus which permits the semaphore arm to go to the danger position by force of gravity. After the operator has cleared the signal, an electric locking machine works in such a way that the signal cannot again be cleared until the train has passed over another section of insulated track as it passes out of the block at the station *B*. When the train passes this second section of track and short circuits the track, an electric current is automatically sent back through line wires to *A* and unlocks the machine, giving the operator at *A* permission again to clear his signal permitting another train to enter the block.

The above description of the lock and block or controlled manual system will make clear the following established principles of interlocking:

1. Each home signal, lever in that position which corresponds to the clear signal must lock the operating levers of all

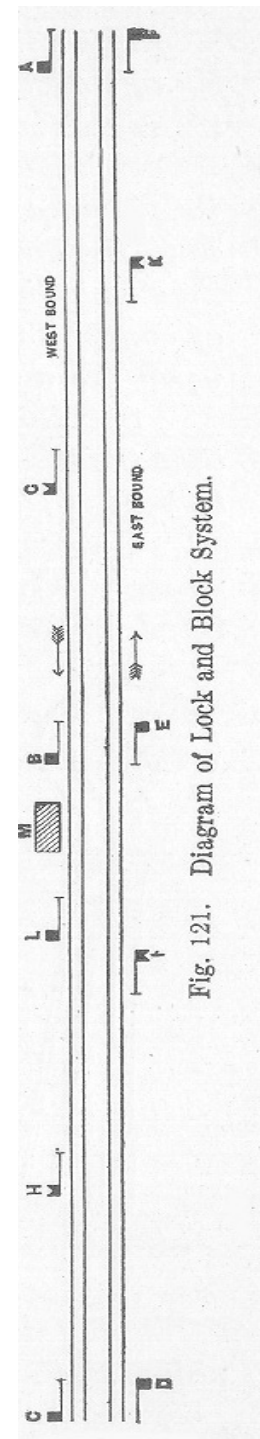

Fig. 121. Diagram of Lock and Block System.

switches and switch locks which, by being moved during the passage of a train running according to that signal, might either throw it from the track, divert it from its intended course, or allow another train moving in either direction to come into collision with it.

2. Each lever so locked must in one of its two positions lock the original home signal in its danger position, that position of the lever being taken which gives a position of switch or switch lock contrary to the route implied by the home signal when clear.
3. Each home signal should be so interlocked with the lever of its distance signal that it will be impossible to clear the distance signal until the home signal is clear.
4. Switch and lock levers should be so interlocked that crossings of continuous tracks cannot occur where such crossings are dependent upon the mutual position of switches.
5. Switch levers and other locking levers should be so interlocked that the lever operating a switch cannot be moved while that switch is locked.

Levers at one signal station are locked from the station in advance. Thus, the signal *A*, [Fig. 121](#), cannot be put to clear until freed by the operator at *B*. *B* cannot be cleared until freed by *C*, etc. Levers and signals may be operated by hand, pneumatic, or electric power, the last two either automatically or by an operator.

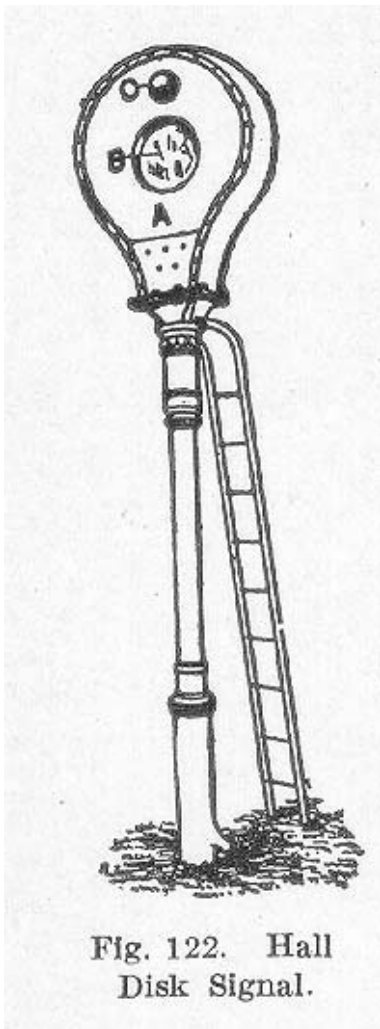

Fig. 122. Hall Disk Signal.

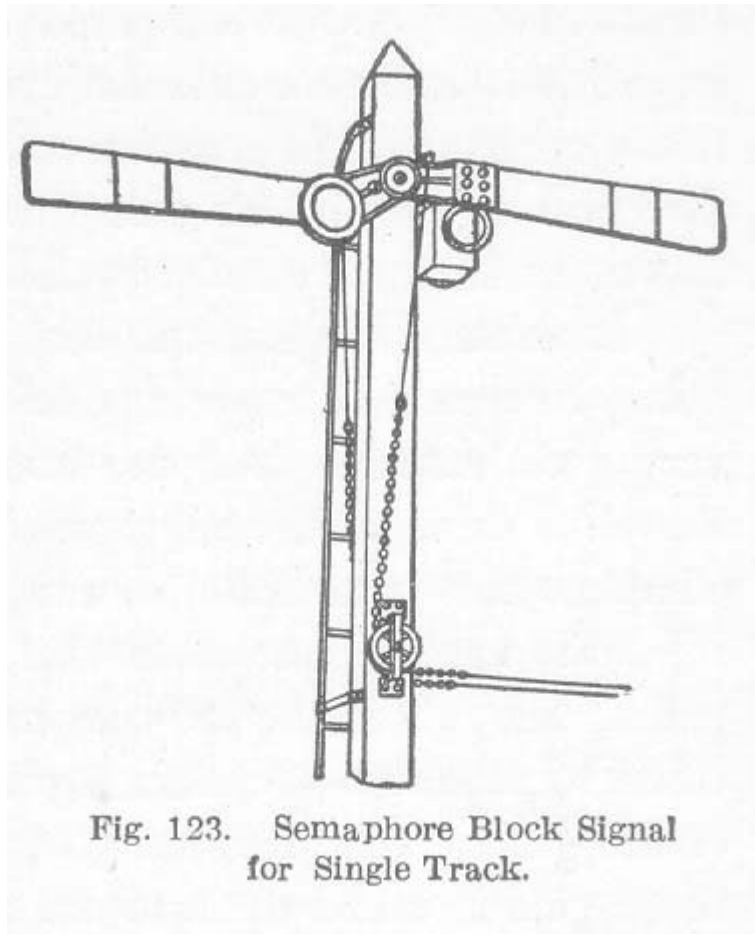

Fig. 123. Semaphore Block Signal for Single Track.

*Hall Signal.* Disk signals are also used for block signaling and are usually automatic. The Hall signal, illustrated in [Fig. 122](#), is an example of this kind. It consists of a glass case *A* containing electric apparatus operated by a current controlled by the passage of a train. When the block is closed, a red disk fills the opening *B* by day, and a red light shows at *C* by night. A clear signal is indicated by a clear opening at *B* by day and a white light at *C* by night.

When a single track is to be operated by block signals, it is customary to put two semaphores on one pole, as shown in [Fig. 123](#). The arm extending to the right as seen from an approaching train is the one controlling the movement of that train.

*Dwarf Signals.* These are in all respects similar to the regular semaphore differing only in their size. They are usually short arms painted red, standing from two to four feet from the ground, and are similar to the home signal. They are used only to govern movement for trains on secondary tracks or movements against the current of traffic on main tracks when such reverse movement becomes necessary, and where necessary in yards. They are especially used for governing the movement of trains in backing out of train sheds at terminals.

*Absolute and Permissive Block Signaling.* Block signaling should always be absolute, that is, when the home signal is at danger no trains should be allowed to pass. It should never be cleared until the whole block in advance is emptied; that is, the signal at *B*, [Fig. 121](#), should never be set to clear until the last preceding train has passed the home signal at *C*.

Permissive signaling introduces a time element into the system and is practiced by many roads. Thus, when a certain time, usually from 5 to 10 minutes, has elapsed after a train has passed a home signal, a following train is allowed to proceed though the signal still remains at danger. The following train is notified of the occupancy of the block by the preceding train by the display of a cautionary signal, usually a green flag or light from the tower at the signal so passed. It is a dangerous system and one subversive of good discipline and safety.

## LOCOMOTIVE OPERATION

**Running.** The actual handling of a locomotive on the road can only be learned by practice with the engine itself. There are, however, certain fundamental principles which must be borne in mind and applied.

**FIRING.** Before taking charge of a locomotive, a considerable period must be spent as a fireman. The first things to be learned are the principles governing the composition of fuels.

The difference between the work of a locomotive boiler furnace and one under a stationary boiler is that in the former the rate of fuel consumption is very much greater than in the latter. In locomotive boilers it often occurs that 150 pounds of bituminous coal is burned per square foot of grate area per hour while a consumption of 200 pounds per square foot per hour is not unusual.

Different fuels require different treatment in the fire-box.

*Bituminous coal* is the most common fuel used on American railroads. It varies so much in chemical composition and heat value that no fixed rule for burning it can be laid down. The work of the fireman varies more or less with each grade of coal used. Ordinarily, the fuel bed should be comparatively thin. It may vary in thickness from 6 to 10 inches or even more, depending on the work the locomotive is called upon to perform. The fuel bed should be of sufficient thickness to prevent its being lifted from the grate under the influence of the draft created by the exhaust.

In order to obtain the best results, the stoking must be very nearly constant. Three shovelfuls at a time have been found to give very good results. The fire door should be closed between each shovelful so as to be only open on the latch. This delivers air to complete the combustion of the hydrocarbon gases which are distilled the moment the fresh coal strikes the incandescent fuel. In placing the fuel in the fire-box, it is well to heap it up slightly in the corners and allow the thinnest portion of the bed to be in the center of the grate. The frequency of the firing depends upon the work the engine is called upon to do.

The fire should always be cleaned at terminals and when the grade is favorable the slice bar may be used and the clinker removed through the furnace door while running.

*Anthracite coal.* In using anthracite coal, it is best, whenever possible, to do the stoking on favorable grades and at stations. The thickness of the fuel bed varies in size with the kind of coal used. It may vary from three inches with fine pea and buckwheat coal to 10 inches with large lumps. The fuel should be evenly distributed over the entire grate. The upper surface of an anthracite coal fire must never be disturbed by the slice bar while the engine is working. When it is necessary to use the slice bar, it should be done only when there is ample time after its completion to enable the fire to come up again and be burning vigorously before the engine resumes work.

**FEEDING THE BOILER.** Feeding the boiler is a matter requiring skill and judgment, especially where the locomotive is being worked to its full capacity. The injector is now the univeisal means employed for feeding the locomotive boiler. Where it is possible, the

most satisfactory way is to use a constant feed which will be average for the entire trip. In this way the water level will rise and fall but will always be sufficient to cover the crown sheet. Under no circumstances should the water level be allowed to fall below the lower gauge cock.

Where a constant feed cannot be used, the injector may be worked to its full capacity on favoring grades and at station stops. This will give a storage of water to be drawn upon when the engine is working to its full capacity on adverse grades. Under such circumstances, the stopping of the feed may enable the fire to maintain the requisite steam pressure, whereas the latter might fall if the injector were to be kept at work. Further, the use of the injector on down grades and at stations keeps down the steam pressure and prevents the loss of heat by the escape of steam through the safety valves when the fire is burning briskly and the engine is not working.

**THE USE OF STEAM.** The manner in which an engineer uses the steam in the cylinders is one of the controlling elements in the economical use of coal. In starting, the reverse lever must be thrown forward so that steam is admitted to the cylinders for as great a portion of the stroke of the piston as the design of the valve motion will permit. As the speed increases, the lever should be drawn back, thus shortening the cut-off. It will usually be found that when the engine is not overloaded, a higher speed will be attained and maintained with a short than with a long cut-off. The reason is that with a late cut-off, so much steam is admitted to the cylinder that it cannot be exhausted in the time allowed, resulting in an excessive back pressure which retards the speed.

Experiments have proven, however, that it is not economical to use a cut-off which occurs earlier than one-fourth stroke, for when the cut-off occurs earlier than this, the cylinder condensation will more than offset the saving effected by the increased expansion so obtained. For this reason when the engine is running under such conditions that a cut-off earlier than one-fourth stroke can be used with the throttle wide open, it may be better to keep the point of cut-off at one-fourth stroke and partially close the throttle, thus wiredrawing the steam. The wiredrawing of the steam serves to superheat it to a limited extent and thus to diminish the cylinder condensation which would occur were saturated steam at the same pressure being used.

When running with the throttle valve closed, the reverse lever should be set to give the maximum travel to the valve in order to prevent the wearing of the shoulders on the valve seats.

**LEARNING THE ROAD.** Learning the road is one of the most important things for the engineer to accomplish. He must know every grade, curve, crossing, station approach, bridge, signal and whistle or bell post on the division over which he runs. He must know them on dark and stormy nights as well as in the daytime. He must always know where he is and never be at the slightest loss as to his surroundings. He must not only know where every water tank is located but should also make himself familiar with the qualities of the various waters they contain. Then when he has a choice of places at which to take water he may choose that containing the smallest amount of scale-forming matter.

*Grades.* In the learning of a road an intimate knowledge of the grades is of the first importance to the engineer. He must know what his engine can handle over them, how it must be handled when on them, and how they must be approached. An engine will



frequently be able to take a train over a grade if it has a high speed at the foot, whereas if a stop or slackening of the speed were to be made at the foot of the grade it would be impossible to surmount it with the entire train.

*Handling Trains.* Handling trains over different profiles of track requires different methods. On adverse grades, the work is probably the simplest. In such conditions the train is stretched out to its fullest extent. Every car is pulling back and the checking of the movement of the front of the train meets with an immediate response throughout the whole train. The grade also prevents sudden acceleration at the front. It is, therefore, necessary merely to keep the engine at work.

On favoring grades, the whole train when drifting is crowding down upon the locomotive and is likely to be bunched or closed together. Under these conditions, it is necessary to apply the air brakes which are at the front end and keep them applied so as to hold the speed under control and prevent the train from running away. Care should be taken in the application of the driving wheel brakes on long down grades lest the shoes heat the tires and cause them to become loose,

The greatest danger of injury to a train arises in passing over ridges and through sags. First, in leaving an adverse grade in passing over a ridge to a favoring grade, the engineer must be careful not to accelerate the front end of the train too rapidly lest it break in two before the rear end has crossed the summit. There is greater danger, however, in running through a dip where the grade changes from a favoring, to an adverse one. Where brakes have been applied at the rear of the train and the slack prevented the train from becoming bunched, there is not the same danger as when the brakes have been applied at the front of the train. In the latter case, if the engineer is not careful in pulling out the slack, the train may be parted. Accidents of this class will be minimized if in every case the slack is taken up slowly. A steady pull will not break the draft rigging of the car, whereas a sudden jerk may pull it out.

In case a train does break in two, the engine and front portion should be kept in motion until the rear portion has been stopped. In so doing a collision may be avoided. Where air brakes are applied to the entire train, the rear portion will stop first owing to the proportional increase of weight and momentum of the locomotive.

Freight trains require on the whole more careful handling than passenger trains. There is more slack in the couplings of the former than in the latter and the trains are much longer, consequently the shocks at the rear of a freight train, due to variation in speed, are much more severe than on passenger trains. The system of handling, while practically the same for both classes, requires more care in order to avoid accidents with a freight train than with a passenger train.

THE END OF THE RUN. When the run has been finished, the engineer should make a careful inspection of all parts of the engine so as to be able to report any repairs which may be needed in order to fit the locomotive for the next run. The roundhouse hostler should then take the engine and have the tender loaded with coal, the tank filled with water, and the fire cleaned. The engine should then be put over the pit in the roundhouse, carefully wiped, and again inspected for defects.

**Inspection.** The inspection of locomotives should be thorough. It should embrace the condition of every exposed wearing surface and the behavior of every concealed one. All bolts and nuts should be examined to ascertain if they are tight. The netting in the front end should be examined at frequent intervals to make sure that it is not burned out. The stay-bolts should be inspected periodically in order that those broken may be replaced. Wheels and all parts of the running gear and mechanism should be carefully scrutinized for cracks or other defects.

**Cleaning.** Cleaning the engine should be done after every trip, since dust and dirt may cover defects which may be serious and ultimately cause a disaster.

**Repairs.** Repairs of a minor nature can be made in the roundhouse and should receive prompt attention. Roundhouse repairs include such work as the replacing of the netting in the smoke-box, cleaning of nozzles, expanding and caulking leaky flues, refitting the side and connecting rod brasses, refitting valve seats, regrinding leaky cab fittings, adjusting driving box wedges, repairing ash pans, replacing grates, renewing brake shoes, resetting valves, repairing water tanks, and sometimes may be extended to the re-boring of cylinders. To this list must also be added the regular work of renewing all packing and cleaning out the boiler.

**Emergencies.** Emergencies are constantly arising in locomotive running where a breakage of some part should be repaired while on the road. The part affected and the extent of the fracture has much to do with the possibility of running the engine home under its own steam. A few methods of dealing with the more common breakages will be given.

*Broken Side Rods.* If a side rod breaks, the ends of the broken rod should be disconnected and the rod on the opposite side of the engine should be removed. An attempt should never be made to run a locomotive with only one side rod connected as the engine would be badly out of balance and trouble would arise when the driver attempted to pass the dead center.

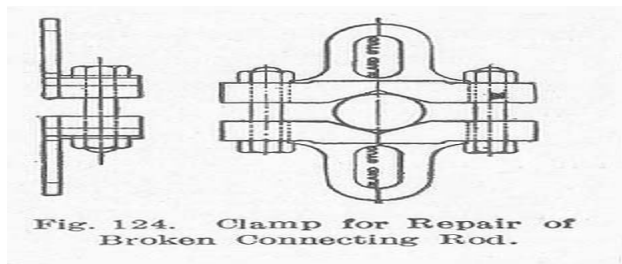

*Broken Connecting Rod.* If a connecting rod is broken without injury to the cylinder, the crosshead and piston should be blocked at one end of the stroke and the broken parts of the rod removed. The removal of the side rods depends upon the extent of injury to the crank pin on the broken side. All side rods should be left in position if the crank pin on the broken side is uninjured, otherwise all should be removed. The valve rod should be disconnected from the rocker arm and the valve stem clamped with the valve in the central position. The valve stem may be clamped by screwing down one of the gland nuts more than the other, thus cramping the stem. It may

also be secured by the use of the clamp shown in [Fig. 124](#). This consists of two parts having V-shaped notches which are securely fastened to the valve stem by a bolt on either side. This is done after having passed the gland studs through the two slotted holes, which prevents any longitudinal movement of the stem after the nuts on the studs have been screwed home. The crosshead should be forced to one end of the guides with the piston against the cylinder head. In this position, it can be secured by a piece of wood cut to fit snugly between it and the guide yoke.

When the parts on one side have been blocked in this way, the engine can be run to the shop with one side working.

*Broken Driving Springs.* In case a driving spring breaks, a block of wood should be inserted between the top of the driving box and the frame. This can be done by first removing the broken spring and its saddle, then running the other drivers on wedges to lift the weight off the driver with the broken spring. The piece of wood should then be inserted and the pair of drivers run up on wedges. After this is done, the fallen end of the equalizing lever should be pried up until it is level and blocked in this position. All parts which are liable to fall off should be removed.

*Low Water.* If for any reason the water gets low in the boiler or if through accident some of the heating surface is laid bare, the fire should be dampened by throwing dirt into the fire-box. A stream of water should never be turned on the fire.

*Foaming.* If foaming occurs, the throttle should be slowly closed. This prevents the water height dropping suddenly and uncovering the crown sheet. If there is a surface blow-off, it should be opened and the impurities on the surface of the water blown off. If the foaming is caused by grease which has collected in the tank, the tank should be overflowed at the next water station and a couple of quarts of unslacked lime placed in it. If this cannot be obtained, a piece of blue vitriol, which may be obtained at almost any telegraph office, may be placed in the hose back of the screen.

*Broken Steam Chest.* In case a steam chest becomes fractured either the lower joint of the steam pipe on the side of the accident should be pried open and a blind wooden gasket inserted, or the steam chest and valve should be removed and a piece of board laid over the steam openings and firmly clamped in position by the studs of the steam chest.

The above are a few of the accidents which may occur on the road. To prepare for emergencies, the best method is to study the locomotive and devise means of making temporary repairs for every accident imaginable, then when the accident does occur, the remedy can be promptly applied.

## TRAIN RULES

The American Railway Association has adopted a uniform code of train rules which have been accepted by the railroads of the United States. These rules, briefly stated, are as follows:

*All trains are designated as regular or extra and may consist of one or more sections. An engine without cars in service on the road is considered a train.*

*All trains are classified with regard to their priority of right to the track.*

*A train of an inferior class must in all cases keep out of the way of a train of a superior class.*

*On a single track all trains in one direction specified in the time table have the absolute right of track over trains of the same class running in the opposite direction.*

*When trains of the same class meet on a single track, the train not having the right of track must take the siding and be clear of the main track before the leaving of the opposite train.*

*When a train of inferior class meets a train of a superior class on a single track, the train of inferior class must take the siding and clear the track for the train of superior class five minutes before its leaving.*

*A train must not leave a station to follow a passenger train until five minutes after the departure of such passenger train unless some form of block signaling is used.*

*Freight trains following each other must keep not less than five minutes apart unless some form of block signaling is used.*

*No train must arrive at or leave a station in advance of its scheduled time.*

*When a passenger train is delayed at any of its usual stops more than — minutes, the flagman must go back with a danger signal and protect his train, but if it stops at any unusual point, the flagman must immediately go back far enough to be seen from a train moving in the same direction when it is at least —feet from the rear of his own train.*

*When it is necessary to protect the front of the train, the same precautions must be observed by the flagman. If the fireman is unable to leave the engine, the front brakeman must be sent in his place.*

*When a freight train is detained at any of its usual stops more than — minutes, where the rear of the train can be plainly seen from a train moving in the same direction at a distance of at least —feet, the flagman must go back with danger signals not less than —feet, and as much farther as may be necessary to protect his train but if the rear of his train cannot be plainly seen at a distance of at least —feet, or if it stops at any point which is not its usual stopping place, the flagman must go back not less than —feet, and*

*if his train should be detained until within ten minutes of the time of a passenger train moving in the same direction, he must be governed by rule No. 99.*

*Rule No. 99 provides that when a train is stopped by an accident or obstruction, the flagman must immediately go back with danger signals to stop any train moving in the same direction. At a point — feet from the rear of his train, he must place one torpedo on the rail. He must then continue to go back at least — feet from the rear of his train and place two torpedoes on the rail ten yards apart (one rail length), when he may return to a point — feet from the rear of his train, where he must remain until recalled by the whistle of his engine. But if a passenger train is due within ten minutes, he must remain until it arrives. When he comes in, he will remove the torpedo nearest to the train but the two torpedoes must be left on the rail as a caution signal to any train following.*

*When it is necessary for a freight train on a double track to turn out on to the opposite track to allow a passenger train running in the same direction to pass, and the passenger train running in the opposite direction is due, a flagman must be sent back with a danger signal as provided in Rule No. 99 not less than — feet in the direction of the following train and the other train must not cross over until one of the passenger trains arrive. Should the following passenger train arrive first, a flagman must be sent forward on the opposite track with danger signals as provided in Rule No. 99, not less than — feet in the direction of the overdue passenger train before crossing over. Great caution must be used and good judgment is required to prevent detention to either passenger train. The preference should always be given the passenger train of superior class.*

*If a train should part while in motion, trainmen must use great care to prevent the detached parts from coming into collision.*

*Regular trains twelve hours or more behind their scheduled time lose all their rights.*

*All messages or orders respecting the movement of trains or the condition of track or bridges must be in writing. Passenger trains must not display signals for a following train without an order from the Superintendent, nor freight trains without an order from the Yard Master.*

*Great care must be exercised by the trainmen of a train approaching a station where any train is receiving or discharging passengers.*

*Engine men must observe trains on the opposite track and if they are running too closely together, call attention to the fact.*

*No person will be permitted to ride on an engine except the engineman, fireman, and other designated employes in the discharge of their duties without a written order from the proper authorities.*

*Accidents, detentions of trains, failure in the supply of water or fuel, or defects in the tracks or bridges must be promptly reported by telegraph to the Superintendent.*

*No train shall leave a station without a signal from its conductor. Conductors and engine men will be held equally responsible for the violation of any rules governing the safety of*

*their trains and they must take every precaution for the protection of their trains even if not provided for by the rules. In case of doubt or uncertainty, no risks should be taken.*



## **TIME TABLES**

Time tables are the general law governing the arrival and leaving time of all regular trains at all stations and are issued from time to time as may be necessary. The time given for each trap on the time table is the scheduled time of such trains.

Each time table from the moment it takes effect supersedes the preceding time table and all special relations relating thereto and trains shall run as directed thereby, subject to the rules. All regular trains running according to the preceding time table shall, unless otherwise directed, assume the times and rights of trains of corresponding numbers on the new time table.

On the time table, not more than two sets of figures are shown for a train at any point. When two times are shown, the earlier is the arriving time and the later the leaving time. When one time is shown, it is the leaving time unless otherwise indicated.

Regular meeting or passing points are indicated on the time table.

The words "Daily," "Daily except Sunday," etc., printed at the head and foot of a column in connection with a train indicate how it shall be run. The figures given at intermediate stations shall not be taken as indicating that a train will stop, unless the rules require it.

Trains are designated by numbers indicated on the time table.

## LOCOMOTIVE TROUBLES AND REMEDIES OPERATING PROBLEMS

**Distinctive Features of Locomotive.** A new locomotive is very much like any other new piece of machinery, in that, if care has been used in its construction by experienced mechanics, it should operate in a satisfactory manner when properly handled. In a few respects it differs very materially from other steam power plants. First, when it is in operation it is not stationary but moves from place to place on a suitably constructed track. This feature alone requires a form of construction peculiar to its kind. As a result we find that the different movable parts involved are far greater in number than in other power plants of equal power and are included in much less space. Second, because of the large number of parts the chances for wear are much greater than in ordinary power plants, and on this account it is not to be expected that a locomotive will operate as quietly after it has been in service for some time as it otherwise would. Then again it must be borne in mind that it is impossible to obtain perfect track conditions, and for this reason the various parts cannot be safely "set up" as snugly as would be possible under ideal conditions.

There are so many points which naturally should come under Troubles and Remedies that it will be possible to mention only a few of the more important.

**Pounds.** For convenience of expression it will probably simplify matters to refer to all disagreeable and annoying jerks and sounds familiar to the locomotive engineer and fireman as "pounds". By different individuals these characteristic sounds may be referred to as clicks, knocks, jerks, thumps, pounds, bumps, thrashes, etc. In actual practice they are sometimes very difficult to locate. If a serious pound is neglected or disregarded, it may be the cause of ultimately disabling the locomotive. Because of this fact an effort should be made to locate all troublesome pounds and report them promptly, for by so doing the engineer will relieve himself of further responsibility. An experienced locomotive engineer naturally becomes familiar with all the various sounds produced by a locomotive when in operation and can very often locate a pound which develops suddenly by the particular sound. Perhaps one of the most difficult pounds to locate is one caused by a loose piston. Improvements made in more recent locomotives reduce the chances for the development of such pounds very materially. When they do develop, they often will deceive old experienced operators. They usually develop rather suddenly and sound as if there was much lost motion somewhere, when as a matter of fact the exact amount of lost motion may be exceedingly small. Such a pound will probably be taken for a loose driving box or crosshead.

*Locating Pound.* Having detected an unusual knock or pound, it should be located and corrected at the first opportunity. When it has been determined from which side of the locomotive the pound issues, it can be definitely located in the following manner: Block the driving wheels as securely as possible with the crank-pin on the side in question at the top quarter and have the fireman open the throttle slightly, to give the cylinders a little steam, and then reverse the engine a few times while an examination is made of the various points where a pound is liable to develop. The crank pin is placed on the upper quarter because in that position the parts are freer to move than with it at any other point. If it were placed at either dead center, steam could be admitted at but one dead center, no matter where the reverse lever was placed.

*Causes of Pounds.* Pounds may result from improper lubrication of various parts, such as the valve and piston, main axle, main crank-pin, and crosshead, or lost motion in the reciprocating parts. Pounds will also result from loose wedges, loose knuckles, wedges down or stuck, broken engine frame, cylinders loose on frame, loose pedestal braces, imperfect fitting of shoes and wedges, loose oil cellars, and shoulders worn on either the shoes or wedges or on both. At times when the boiler is priming badly, water in sufficient quantities may enter the cylinder and cause pounds and endanger the safety of the parts. Improper valve setting or adjustment may be the cause of pounds or noises of different character. In this case the usual cause would most probably be too late admission or too great compression. Other conditions remaining the same, admission should increase as the speed increases. In order to determine whether or not the valve adjustment is responsible for unusual noises or knocks, it will usually be necessary to take indicator diagrams from which a study can be made of the steam distribution.

The valve gear or reversing mechanism is frequently the cause of numerous rattling noises. The valve gears commonly employed embody a number of pins, links, movable parts, etc., which become worn and result in lost motion. The wear on any one part may not be very noticeable, but in the aggregate the lost motion may be quite large. The locomotive engineer can usually locate the badly worn parts when the locomotive is stationary by having the fireman throw the reverse lever first forward then backward, repeating the operation as often as necessary, while inspecting the various parts. This method would probably not disclose lost motion which might exist in the eccentrics.

The side rods cannot be operated successfully if adjusted too snugly. For this reason they are made to work with freedom and frequently produce a rattling sound. This rattling should not be confused with a pound.

**Steam Waste.** The steam necessary to do the work in the cylinders required in hauling a train of a given tonnage at a given speed is very often augmented by wastes of various kinds, which should be reduced to a minimum. These wastes may be due to improper care of the engine, either on the road or in the roundhouse or both, to improper manipulation when on the road, and to the use of bad water. Still other wastes may be due to high steam pressures and high rates of evaporation.

*Waste from Piston and Valve Rods.* The most common sources of leakage are steam blows. When these occur into the atmosphere from the piston and valve rods, it is quite noticeable, and they may constitute a very great loss, especially where high steam pressures are employed. Besides being a direct loss, under certain conditions the presence of the steam in the air may obstruct the view ahead, making operation more hazardous. Anything which causes undue vibration of the piston and valve rods will eventually cause leaky packing. For this reason the guides should be kept in proper adjustment to prevent vertical movement of the crosshead. In engines using piston valves with inside admission, there will ordinarily not be trouble by steam leaks around the valve rods.

*Waste from Cylinder and Valve Piston Packing.* It sometimes happens that losses occur due to steam blowing past the packing rings of the cylinder piston or the valve. Indicator cards will usually show such leaks, but as a rule they can be detected by the sound of the exhaust. Such steam blows are more difficult to locate in compound than in simple engines. A practical method of detecting steam blows past the cylinder and valve piston

packings consists in blocking the engine in different positions of the crank and noting the presence or absence of steam at the cylinder cocks or stack.

*Waste Due to Priming.* The use of water which causes priming eventually causes steam blows. Priming is frequently so serious that the whistle cannot be blown without closing the throttle in order to reduce the water level in the boiler. In aggravated cases where water is carried over into the cylinders, it not only endangers the cylinder heads, etc., but sooner or later injures the piston and valve packing, piston and valve rod packing and valve seat, causing leaks and serious waste of steam.

*Waste from Safety Valve.* Another common waste of steam occurs through the safety valve, caused oftentimes by a careless manipulation of the fire. Such losses occur most frequently when the locomotive is standing on a siding or coasting. This may seem to be a small matter, but if we consider a road using 1000 locomotives per day and each fireman permitting the safety valve to blow on an average of 10 minutes per day, the amount of steam wasted daily would approximate 1,000,000 pounds, which would represent a waste of fuel per day of about 75 tons. Such waste can be reduced to a minimum by the intelligent manipulation of the injectors, dampers, and fire door.

**Care of Boiler.** *Importance.* The life of a locomotive boiler depends largely upon the systematic and intelligent attention it receives and the particular locality in which it is used. The time elapsing between cleanings and washings varies between wide limits with different roads and different localities, depending largely upon the character of the service and water used. The proper blowing out by the engineer in order to prevent undue concentration of material in solution is of much importance. Some roads require this blowing out to be done while running and others at terminal points. The removal of sediment or sludge, such as soft scale, mud, etc., can best be accomplished at terminals after the water has had time to become more quiet.

Much importance is attached to the manner of cooling down and washing out. When done hurriedly the boiler usually suffers. The following directions for washing and cleaning boilers are abstracted from instructions furnished employees by one of our well-known railroads.

*Cooling Boiler.* Boilers should be thoroughly cooled before being washed. When cooled in the natural way, the steam should be blown off and the water retained above the top of the crown sheet and allowed to stand until the temperature of the steel in the fire-box is reduced to about 90° F., after which time the water may be drawn off and the boiler washed. When the locomotive cannot be spared from service long enough to be cleaned in this manner, the following plan should be carried out.

After the steam pressure has dropped considerably, start the injector and continue filling the boiler until the injector will no longer operate. Then connect the water pressure hose to the feed hose between the engine and tender and fill the boiler full, permitting steam to blow through some outlet at the top of the boiler. Next open the blow-off cock or valve and permit the water to escape, but at a rate less than that entering from the water hose, so as to keep the boiler completely filled. Continue the process until the fire-box sheet has been reduced in temperature to about 90° F., at which time shut off the water, open all plugs, and allow the boiler to completely empty.

*Washing Boiler.* Washing may now be begun by first washing the flues by the side holes opposite the front end of the crown sheet. Next wash the top of the crown sheet at the front end, then between the rows of crown bars, if provided, and bolts, directing the stream toward the back end of the crown sheet. After washing through the holes near the front end of the crown sheet, continue washing through the holes, in order, toward the back end of the crown sheet, in such a manner as to work the mud and scale from the crown sheet toward the side and back legs of the boiler and thus prevent depositing it on the back ends of the flues. Continue washing, using the holes in the boiler head, with the swivel attachment on the hose, working from the front to the rear, endeavoring to thoroughly wash the top of the boiler as well as all stays and the crown sheet.

Next wash the back end of the flues through suitably located holes and afterward the water space between the back head and the door sheet through the holes in the back head, using the angle nozzle. The inside arch flues should also be washed thoroughly from the back head and scraped with the proper form of scraper.

If washout plugs are provided in the front flue sheet, wash through them, using a long pipe nozzle of sufficient length to reach the back flue sheet. If the holes are among the flues, the nozzle should be a bent one and should be revolved as it is drawn from the back end toward the front.

Now wash through the holes near the check valves at the front end of the boiler, using straight and angle nozzles with swivel connection. Then wash through the holes in the bottom of the barrel near the rear end, using the straight nozzle directly against the flues and reaching as far as possible in all directions. Both the straight and bent nozzles should now be used through the front hole in the bottom of the barrel, in the same manner as before, to clean the flues and the space between the flues and the barrel.

After washing the barrel completely, clean the back end of the arch flues, making sure they are free from scale. Next by using bent nozzles in the side and corner holes of the water legs, thoroughly clean the side sheets and finally clean off all scale and mud from the mud ring by means of straight nozzles in the corner holes. It should not be assumed that because the water runs clear from the boiler that it is clean and free from scale. Carefully examine all spaces with a rod and light and, if necessary, use a pick, steel scraper, or other suitable tool in removing the accumulation of scale.

**Drifting.** In operating a locomotive on the road the engine frequently runs with a closed throttle, as is the case in bringing the train to a stop or when "dropping" down grades. This condition is known and spoken of as *drifting*. Under such circumstances there may be little or no steam in the cylinders yet the effects of expansion and compression will be present. As a result, if the reverse lever is set near the central position the compression will be relatively high and expansion will be carried so far that a vacuum will result which will draw gases and cinders from the "front end" through the exhaust pipe into the cylinders. It is easily seen that the presence of smoke and cinders in the cylinders may prove to be a serious matter.

To prevent the conditions just described from arising, the reverse lever, when drifting, should be carried in the full position corresponding to the direction of travel, for in this position a vacuum will probably not be formed and no foreign matter will enter the cylinders. As a safeguard against damaged cylinders and valves both steam chests should

be fitted with relief valves. Such valves are applied one to each steam chest and are arranged to open inwardly and admit atmospheric air whenever the pressure in the steam chest falls below that of the atmosphere and to close suddenly when the throttle is opened. They should be constructed to open by gravity so when once opened they will remain open and will not be worn out by being rapidly opened and closed during the drifting period. It is important that they be made of ample size to admit air freely, otherwise at high speeds a vacuum might be formed in the steam chests and smoke and cinders still be drawn into the cylinders.

**Fuel Waste.** Leaks or wastes of steam or hot "water are always a direct drain upon the coal pile from which no benefit is received. The different ways in which steam is wasted, which were considered under Steam Waste, constitute a loss of fuel. The presence of scale on the heating surface of the boiler reduces the amount of heat which could otherwise be transmitted, thus requiring more coal to be burned, which is a waste of fuel. There are other large wastes of fuel in which steam plays no part, such as the generation of smoke and carbon monoxide, the emission of sparks, and the loss of coal which never enters the fire door.

*Waste from Smoke.* Of all the losses attending the firing of bituminous coal that due to the generation of smoke attracts the most attention since it is so readily seen because of its color. When such coal is thrown into a hot furnace the lighter hydrocarbons are distilled off first, and if an insufficient supply of oxygen is furnished to completely burn them, smoke will be observed coming from the stack. The actual heat loss in carbon contained in the smoke is small as compared to that in the carbon monoxide gas formed. Both of these losses are due to an insufficient supply of oxygen furnished by the air. The presence of smoke indicates a shortage of air and for this reason is a valuable guide to efficient firing. The temperature must be maintained sufficiently high to burn the gases as they are driven off the coal. No part of the fire-box should be permitted to become chilled, and in order to maintain a uniform temperature over the entire surface of the fire, the coal must be evenly distributed. To insure rapid burning, the large pieces of coal should be broken up so as to present a more nearly uniform size. An alert and efficient fireman will endeavor to take advantage of the physical characteristics of the road and will fire lightly and regularly, keeping the fire door slightly open for a few seconds, if necessary, to admit sufficient air to burn the lighter gases which are driven off. The steam gage should be constantly watched and the supply of air regulated as far as possible by the dampers. Much good will result from the engineer co-operating with the fireman in handling the locomotive in an intelligent, manner and informing him from time to time of his intended movements.

*Waste from Sparks.* The loss in cinders and small pieces of coal being ejected through the stack is quite large. In extreme cases it may reach 10 or 15 per cent of the total weight of the coal fired. The heating value of these *sparks*, as they are usually termed, varies between 70 and 90 per cent of the coal as at first fired. Sparks are not only wasteful of coal but are very dangerous to property in the immediate vicinity of the track. For these reasons the fireman should endeavor at all times to handle his fire in such a manner as to minimize the amount of sparks formed, and the netting in the front end should be kept in constant repair to prevent large holes from forming which would permit large quantities of sparks to be thrown out.



## LOCOMOTIVE BREAKDOWNS

**Possible Causes.** In the operation of a railroad it is of great importance that trains should be kept running on schedule as nearly as possible. It frequently happens, however, that accidents to the locomotive of greater or less consequence prevent trains from maintaining their schedules, which in many instances could be avoided by a little forethought on the part of the engineer. The efficient engineer who inspects his engine regularly for loose bolts, nuts, and keys, looks for defects, and carefully examines any cracks, flaws, etc., is seldom troubled with annoying and sometimes dangerous accidents while on the road. Breakdowns will, of course, occur at times even though all precautionary measures have been taken. Space will not permit of reference to the many different accidents which may occur. The following list contains those most commonly experienced:

1. Collision of two approaching trains
2. Collision of a moving with a standing train
3. Collision of trains at the crossing of two tracks
4. Running into an open drawbridge
5. Engine running with no one on it to bring it under control
6. Derailment of the front truck, drivers, or tender
7. Explosion of the boiler
8. Collapse of a flue
9. Overheated crown sheet
10. Running into an open switch at too great a speed
11. Blowing out of a bolt or cock or any accident which leaves a hole in the boiler for the escape of steam or water
12. Failure of the injectors or check valves
13. Breaking or bursting of a cylinder, cylinder head, steam chest, or steam pipe
14. Breaking or bending of a crank pin or connecting rod
15. Breaking of a tire, wheel, or axle
16. Breaking of a spring, spring hanger, or equalizer
17. Breaking of a frame
18. Failure of any part of the valve gear
19. Failure of the throttle valve
20. Breaking of the smoke-box front or door
21. Failure of the connection between the engine and tender or between the tender and first car
22. Failure of the air pump or braking apparatus

In case of an accident it is assumed that the engineer will first comply with his book of rules in regard to signals, flagman, etc., and will not overlook or neglect the boiler while working on a disabled engine. If the locomotive has left the track and is in such a position that the crown sheet is exposed, the fire should be killed at once if at all possible. This can be accomplished by throwing dirt, gravel, etc., into the fire-box. If water is convenient it can be used, but with great care.

**Derailments.** If the locomotive leaves the rails for any reason whatsoever, the throttle valve should be closed and the brakes applied. As soon as the locomotive has come to a stop, protection should be made against approaching or following trains. If the

locomotive remains in an upright position and the crown sheet and flues are protected by being covered with water, the fire need not be drawn. In case they are exposed the fire should be drawn, or covered with dirt, gravel, or fine coal, or quenched with water. If not off too badly or too far away from the track, the engine can usually be made to help itself on without the aid of another by using blocking under the wheels and by the aid of "replacers". The engine can, as a rule, be placed on the track easier by moving it in a direction opposite to that in which it ran off.

If conditions are such that the locomotive cannot help itself on the track, it will probably be necessary to secure the assistance of another. If it is too great a distance from the track or over on its side, it will be necessary to send for the wrecking crew.

**Explosion of Boiler.** It is not always possible to determine the real cause of a boiler explosion, since it sometimes happens that all evidence is obliterated. It has been said that all boiler explosions are due to the fact "that the pressure inside the boiler is greater than the strength of the material of which the boiler is constructed". Failure is due to one of two causes, namely, insufficient strength to withstand the ordinary working pressures, or a gradual increase of pressure in excess of that which it was designed to carry.

Lack of strength may be due to incorrect design, defective material and workmanship, or reduction in size of plates, stays, etc., due to corrosion, wear and tear, and neglect. Overpressure is usually due to defective safety valves or to safety valves set by pressure gages which indicate pressures much less than the real amount.

**Collapse of Flue.** If a flue collapses while in service, the escaping steam and water will usually extinguish the fire. When the pressure is reduced sufficiently, an iron or wood plug can usually be driven into the ends of the tube in question, which will effect an emergency repair and permit the locomotive to return under its own steam. It may be necessary to run under a reduced steam pressure. The injectors should be used in reducing the pressure to make sure of plenty of water being kept in the boiler. Iron plugs are preferable but, if they are not at hand, wood plugs may be used. The iron plugs are placed with a long bar. The wood plugs are made on the end of a pole and partially cut off, so that when placed they can easily be broken off. The plug will burn slightly but not to any great extent inside the end of the flue. If the failure occurs in a flue located back of the steam pipes, it may be necessary to let the boiler cool down before the temporary repair can be made. If the steam obscures the back end of the flue, it sometimes can be drawn up the stack by starting the blower.

If a fitting is accidentally broken off permitting steam or water to blow out, or if a hole is made in any way which permits the escape of steam or water, either can be temporarily repaired in the manner indicated above. Metal plugs are preferable but wood can be used if necessary. In plugging flues or any holes where steam or water is escaping, care must be exercised to prevent being struck by the plug in case it blows out.

**Disconnecting after Breakdown.** The disconnecting of one side of a locomotive usually implies that the machine is to continue its journey. It is made necessary by an accident to a cylinder piston, piston rod, steam chest, valve gear, connecting rod, etc. As an example, let it be assumed that a locomotive has met with an accident and one of the cylinder castings is broken. The work that must be done in order that the locomotive may continue its journey is explained in the following:

*Method of Procedure.* If the crank-pin, connecting rod, and crosshead are uninjured, they need not be removed, but the piston rod should be disconnected from the crosshead and the piston and all removed from the cylinder. If, however, any of the above-mentioned parts are injured and will not function properly, then the main or connecting rod must be taken down on the injured side. In removing the rod care should be exercised to keep all the rod attachments in place as that will be of much assistance when replacing the rod. Next move the piston to the back end of the cylinder as far as it will go and fasten securely by placing wood blocks between the guides so as to fill the space between the cross-head and the end of the guide bars. As a safeguard the wood blocks should be secured by means of rope to prevent them from falling out of position should they become loosened. On some types of locomotives it may not be possible to block the piston in the extreme backward position because of a lack of clearance. In such cases the crosshead should be blocked in the forward position. The back position should be used whenever possible, because if the crosshead became loose in that position and was shot forward it would do less damage than if freed from the forward position. After the crosshead is securely blocked, the valve rod should be disconnected from the rocker and valve stem and the valve moved to its central position so as to cover both steam ports and prevent steam from entering the cylinder. By opening the cylinder cocks and slowly admitting steam by means of the throttle valve, it can be known whether or not the valve is correctly located. If not properly located steam will blow from one of the cylinder cocks. If no steam is discharged at either cylinder cock it is probably correctly set. When it has been correctly set the position of the valve must be secured by clamping the valve stem and wedging or tying it in place. With these changes properly made, the locomotive should be able to proceed on its way with but one side doing work.

In case of injury to both sides the locomotive would not be able to proceed under its own power. The connecting rods may be removed from both sides if the conditions demand it but the side rods should not be removed unless seriously damaged. When the locomotive is proceeding with one side only doing work and it is necessary to remove one or more of the side rods because of injury, the corresponding side rods on the other side should also be removed. Under such conditions the speed of the locomotive should be kept very low because of the effect of the counterbalance on the track.

When both sides are disconnected and the locomotive is being towed back to the shop, attention must be given to proper draining of the various pipes, etc., if the temperature is below the freezing point. It is never necessary to remove the eccentric straps unless it becomes so on account of some injury.

The accidents to a locomotive when in service are numerous. Some may be more serious than others. Space does not permit covering all the possible emergency repairs which it may be necessary to apply. In most cases the character of the breakdown will suggest the remedy.

## DUTIES OF LOCOMOTIVE ENGINEER\*

### WATCHING HIS ROAD

\* The following observations on Locomotive Driving were prepared by John H. Jallinga, Mechanical Engineer, Chicago.

**Acquaintance with Route of Prime Importance.** To the casual observer a locomotive runner has a fairly easy billet. Perhaps not one person in a hundred of those who see him sitting in his cab, complacently awaiting the signal to start his train, has any idea of the multiplicity of his duties.

Of course, as a prerequisite to all his other functions comes the care of his engine, either standing or under way, but interwoven with this knowledge are other matters of detail, for example, an intimate knowledge of his time table as it applies to the different parts of his-run. This he must have learned so thoroughly that he can instantly say how long it should take to travel on schedule time between any two points in his run. To be able to accomplish this it is absolutely essential that the engineer know the grades, the curves, the switches, the sidings, the crossings, the stations, and the semaphores he will have to go over or pass *en route*. This means that he will have to know them thoroughly, both backward and forward, for having completed his run today he will have to return by the same route tomorrow, in which case all these items will come to him in reverse order.

These features have such an important bearing on the successful performance of his duties that were he ever so skillful in the care of his engine, he would be quite incompetent to take his engine and train over another route which was unfamiliar to him. This statement may seem somewhat paradoxical, yet it is absolutely true and in our development we will try to make the reason clear.

**Regulating Steam Supply.** There is no type of boiler which has to supply such an abundance of steam on short notice as that of the locomotive. Nevertheless, with all its capabilities, conditions frequently arise during the run which test its capacity to the limit and make it absolutely necessary to conserve the boiler resources.

*Preparing for Grade.* Thus on approaching a heavy up-grade, the skillful engineer will see that his fireman so stokes his fire that there is a thick bed of fuel on the grates and will himself pump water into his boiler to as high a level as can be carried with safety; all this must be accomplished just before the engine arrives at the foot of the grade. While climbing the grade the feed water is shut off, the furnace door is kept closed, and the throttle opened just far enough to enable the engine to mount the grade on schedule time, making it without unnecessary strain or labor.

If these precautions are neglected, the fireman will have to shovel fuel so hard during the climb that he will become exhausted before the summit of the grade is reached; this drawback, coupled with the large losses in steaming capability due to opening the furnace door for the purpose of stoking, will prevent the engine from maintaining the requisite head of steam for making this part of the run on schedule time.

*Good Firing Practice.* Theoretically, no air should be permitted to enter the furnace that does not pass through the fire but in practice this cannot be accomplished, because every time the fire door is opened it admits a large volume of cold air which passes over (not through) the fire directly into the tubes, tending to cool the water and decreasing the

boiler's steaming capacity, For this reason, the stoking should always be done a very few shovelful at a time and the fire door quickly closed to give the fire a little time for recuperation before re-firing. Another very essential duty of the fireman in stoking is to watch for *holes* in the fire. For various reasons, some portions of the bed of fuel will burn out quicker than the rest, and wherever this occurs it leaves a hole through which air will pass in greater volume than through the rest of the fire; as this air is comparatively cooler than if it had forced its way through the burning fuel, it has the same effect on the steam-making power of the boiler as the open fire door, though not to the same extent. Hence, the skillful fireman, on opening his furnace door, will look for these holes and fill them with fuel when he fires; if more of them appear than he can fill at one time he must stoke more frequently.

The bed of fuel should be kept, as far as possible, at a uniform thickness of about 10 to 12 inches although some engines are designed for a heavier bed than this. The coal is usually broken into pieces of 2½ to 3 inches and enough for one stoking is laid on the deck of the engine before the fire door; the shovel is also heaped full and held ready before the fire door is opened, thus accomplishing the firing as quickly as possible.

**Taking Advantage of Downgrade.** It will readily be seen from the preceding description how essential it is that the driver and his fireman should know the exact location of the grades and the necessity for due preparation. Of course on the return trip the same grade will have to be retraversed but with all the running conditions reversed. In this case the throttle should be closed, the train running down hill without steam, and the reverse lever should be thrown forward into the last notch of the quadrant; this gives the cylinder valves full stroke in order to equalize the wear on the valve face as much as possible, for at this time the absence of any lubricant between the valve and cylinder face is liable to cause more rapid wear than under ordinary working conditions. Under such conditions in former days, it was a part of the fireman's duty to walk out on the foot board and tallow the valves, that is, to introduce a lubricant through a tallow cup in the steam chest cover. Today, most engines are fitted with sight-feed lubricators which feed cylinder oil constantly to the valves and cylinders while the engine is in motion under steam.

The attentive engineer will also take advantage of this opportunity to replenish the water in his boiler, if necessary, because he can pump up while not using steam and at the same time prevent the pressure in the boiler from rising to the blowing-off point. In the interests of economical operation, such a condition is to be avoided but may easily arise when no steam is being used and with fuel burning on the grate bars. For this reason the damper should be closed, care having been taken before reaching the downgrade to let the fuel bed get thin. On its way down, the fire can be cleaned and fresh fuel added in readiness to resume steam-making as soon as the level is reached again.

**Curves.** The exact location of every curve on the run must be known to acertainty, first, because it is essential, in order to avoid derailment and for general safety that the speed of the train be slackened below the normal while passing around curves. All curves are constructed with the outer rail some inches higher than the inner rail, the exact amount being determined by the radius of the curve and the speed with which the train should make the curve. This tilting of the train counteracts to some extent the centrifugal force developed in rounding the curve but this precaution must be supplemented by slackening the speed also. Again, many curves occur in cuts, that is, at places where it has been found essential, in making the roadbed, to cut through a small hill so as to preserve the

uniformity of the grade. Sometimes a curve will occur in a woods or at the entrance to a forest, and it would be manifestly dangerous to approach and enter such a place without giving warning of the approach of the train. Hence it is the rule, when approaching a curve, to sound the whistle before arriving at the curve. This precaution is more especially essential if it be a single track road.

**Switches.** A knowledge and a clear remembrance of the location of all switches and sidings are necessary because of the liability of a switch onto the main line being left open through neglect or willfulness. Therefore, the driver on approaching a switch observes first of all the position of the switch target, next the position of the rails, never trusting to the target alone, for sometimes rods connecting the target with the track get disconnected or bent; the engineer can see very clearly whether the track he is running on forms one continuous line past the switch or not. He should, at the same time, assure himself that the frog and wing rails have not become misplaced. These are conditions that do not very often arise but when they do the consequences are so terrible, if not seen in time, that it pays to be on the lookout for them constantly. The main point is to have the train well in hand at all times, and to this end speed must be reduced when passing switches or the ends of sidings. All station yards have a number of switches, and it is customary to slow down while going through them, more especially if intending to stop there. But many trains pass through the smaller towns without stopping and must also frequently pass sidings at certain places on the line between stations and all these places must be watched closely by the driver. In order to do this properly, he must know beforehand when he is about to approach them.

**Culverts and Bridges.** The location of every culvert and every bridge must be known and a keen lookout kept for any derangement in connection with them. Swing and draw bridges are usually guarded by a semaphore, and it is the rule on nearly all roads that every train shall come to a FULL STOP about 200 feet from the bridge approach and await the dropping of the semaphore arm before proceeding, and then only at a slow speed until the bridge has been crossed.

**Running Time.** It is considered an unpardonable offense for an engine driver to arrive at a station ahead of time though some roads do allow one minute variation. This latter is not material, provided it is borne in mind and the rule lived up to; the idea is to have the right of way clear before the arrival of the train, for otherwise a very embarrassing result may ensue.

For these reasons it is very essential that the engine driver make himself thoroughly acquainted with his time table. He must not only know the exact time he is due at any station on his run, but he must know by rote just the number of miles between stations, mentally calculating the necessary speed of his train and seeing that his engine meets the requirements between stops. These speeds vary because of road conditions, and proper allowance must be made for grades, curves, conditions of roadbed, etc., otherwise it will be impossible for him to meet the requirements. Hence, the driver automatically registers in his mind certain landmarks along the road—a house here, a certain tree there, a hill, a stream, or a huge boulder at other places—and he gets to know that he should pass each one of them at a given time going in one direction or the other. He also knows that a certain curve, a culvert, a siding, or a bridge lies one mile, a halfmile, or a quarter-mile beyond one or the other of his landmarks and by these indications he knows it is time for him to perform certain of the duties already described.



**Block Signals.** Many roads, especially in the older portions of this country where the traffic is heavy, use a double track extending for 80 or 90 miles outside some of the large cities and often all the way between important cities. Wherever double track is used, the block system of signals is installed, thus relieving the engine driver of many of the anxieties connected with running trains on a single track road and making the road safe for traffic.

It is not within the province of this article to discuss block signals except as to their effect on the duties of the man who watches over the destinies of the train committed to his care. Briefly, the right of way is divided into sections called blocks and at the commencement and end of every block there is a manually or automatically operated signal over each track; unless the driver sees that his signal shows the way is clear he must not enter a new block. On approaching a station, he must also look for the signals showing way clear and on arriving at a station must observe the semaphore arm projecting from the front of the station over the track; it may be that orders are awaiting him, which it is his duty to read and follow.

It will readily be seen from the above description of a portion of a locomotive driver's duties why it is essential to the proper performance of his work that he should know the road thoroughly.

## CARE OF LOCOMOTIVE

**Watching His Engine.** While the engineer is attending to the matters just enumerated he must not neglect his engine. It would be a difficult matter to decide which of the numerous features to be watched are the most important but it goes without saying that the steam pressure and the water in the boiler are those which will require the most constant watching because they are liable to change, in fact are constantly changing unless foresight is used to keep them normal. In addition to these points, he must be eternally on the lookout for the condition of the working parts of the machine he is operating. To give a clear idea of the the conditions under which his machine is working, we will assume that he is running a passenger train and that his average speed between stations is 50 miles per hour and that the driving wheels are 5½ feet in diameter.

**Oiling Parts.** Now at a speed of 50 miles per hour the engine would have to make 260 revolutions per minute and all the reciprocating parts of the engine, such as the crossheads, the rock shaft, the pistons and rods, the valve stems and valves, the links and lifters, would vibrate just twice this number of times. This is very rapid motion for such heavy parts and there is a liability of great wear in these parts unless they are kept properly lubricated. The only time the engine man can get the opportunity of supplying them with oil is while his engine is standing, and usually the stops are short. Hence, he must see that these parts are provided with large oil cups holding a good supply of oil and feeding oil to the working parts of the machine in an exact and very regular manner. Lack of space will not permit a description here of the various devices in use, but whether the cups are made to feed through the medium of a spring, of reciprocating parts, or of capillary attraction, the engineer must be thoroughly familiar with their operation; in his leisure time in the roundhouse he should see to it that the oiling devices are so adjusted that they will perform their required functions while the engine is on the road. Some of the moving parts require more oil than others and the feed of the various oil cups must be set to suit the requirements; if any cup should feed too fast, it will waste the lubricant and probably will run out of oil too soon, or if too slow the moving part will run dry and cut.

All engines are provided with two oils, one of a heavy body for such places as the pedestal boxes in which the axles of the driving wheels run and on the journals of which there is an enormous pressure, and the other a light oil for the connecting rods, guides, links, lifters, eccentrics, rock and tumbling shafts. The pedestal boxes have a large reservoir called a *cellar* and a means of keeping the oil always against the lower part of the journal and hence these parts do not require such constant watching. The other parts mentioned, however, have to be watched constantly and the amount of watchfulness required is not always the same for the different parts at all times, for weather conditions frequently influence them. For instance, certain parts—such as the eccentric straps, the guides, the links, and lifters—in ordinary weather or on damp cool days will run very smooth and cool while on a hot dry dusty day they will need careful watching; the dust raised from the roadbed by the rapid motion of the engine over it will be quite considerable and a large amount of it will settle on these parts in the form of grit which will cut the parts badly unless the oil feed is liberal and frequently replenished. For all these reasons, the careful man will, when his train stops at a station for a minute or two, jump down from his cab with his oil can and walk round his engine, touching the ends of the driving axles, the crank pins, etc., with the back of his left hand to ascertain if their temperature is normal and at the same time replenishing the oil cups if found necessary. He does not oil every part in this way each time but divides them up mentally into

groups, oiling one group at one stopping place and another at some future time; nor does he go through the oiling process at every station unless these are quite far apart. Experience teaches him about how often to do it, a good maxim being to oil too often rather than sparingly until he has learned just how much is needed and how often. The back of the hand is used to try the temperature of the bearing because it is considered more sensitive than the palm or the ends of the fingers owing to the absence of calloused skin.

Very few engineers travel without a supply of flour of sulphur to use in case of a hot box.

**On the Road. Starting.** On starting out from a station the reverse lever is thrown forward into or nearly to the last notch in the quadrant. The cylinder cocks are opened and, when the signal comes to start, steam is admitted to the cylinders and the engine starts slowly. After running a short distance so that the train has acquired some momentum and the cylinders have become warmed, the cylinder cocks are closed and the reverse lever is pulled up several notches on the quadrant. This has the effect of making the travel of the valve shorter, of giving more lead to the valve, and of cutting off the supply of steam to each end of the cylinders before the end of the stroke; at the same time the throttle is opened a little wider. The effect of all this is to cause the steam to impinge on the pistons at the beginning of each stroke with more force and in greater volume, with the result that the engine picks up, or increases its speed; when this condition has been attained, the reverse lever is pulled up a few more notches and the throttle opened a little wider until the desired speed has been attained.

*Running at Speed.* Now while this is being done the engine man does not for one moment take his eyes off the right of way; he is watching the track, the semaphores, and everything before him. Having gotten safely away from the station yard and out on the main track, he then has time to look at the pressure and water gages, etc., a glance being sufficient to show him if everything is as it should be. He may seat himself or he may stand on the foot board, as suits his convenience, but the careful man will, in either position, keep his hand almost constantly on the reverse lever; this is his means of knowing if his *motion* is working right. By this term is meant that part of the mechanism which operates the cylinder or distributing valves, such as the eccentric rods, the links, the lifters, etc. Should anything happen to any of these parts it can be instantly detected if his hand is on the reverse lever. In addition to this, the engineer's attention is directed to the main and side rods on his side of the engine and to the beat of the exhaust steam as it escapes from the smokestack. An experienced engine man, listening to the exhaust of his own engine or of an engine at a distance, can tell at once whether the valves are working square. He can discern at once by the pulsations of the engine he is riding on, if all the parts are working in unison.

The attentive and careful man never allows his mind to wander for a moment from these symptoms for it is imperative, in case of emergency, that he act quickly. To this end he devotes a portion of his leisure time to thinking up what will be the best course of action in certain emergencies, going over carefully every possible occurrence that might take place and what should best be done under the circumstances. These matters he commits carefully to memory so that when the emergency arises he will act instantly without reflection, for when the time arrives to act there is no time to reflect or consider, and unless he is prepared beforehand he will be lost. Consequently, whenever a fellow craftsman meets with a casualty he is interested to learn all the details, including the

course of action taken under the circumstances and the criticisms of those who are experienced in such matters. This gradually educates his mind to such a point that when anything happens to his engine he acts automatically much more quickly than anyone can think.

*Making Adjustments En Route.* The pedestal boxes, brasses on the connecting rods, eccentric straps, and other moving parts are usually adjusted by the engineer while *en route* because these matters cannot be attended to in the shop. A knocking connecting or side rod must be tightened up a very little at a time until the knock is all taken out; if tightened up all at once it would heat, so it is adjusted a little at a time until it runs quietly. The side, or parallel, rods can never be made to run as closely keyed up as the connecting rods because they do not need to be and because a certain amount of looseness is desirable. These rods are always fitted with about 1/16-inch side play between the collars on the pins because in rounding a curve, the driving and trailing wheels are not exactly in line and if the brass boxes in these rods fitted snug between the collars on the pins they would jam and become sprung. Hence, when the engine is standing and he sees that on one side of the engine the pins of these wheels are in a horizontal position, he takes hold of the rod in the middle and tries it to see if it will move freely sidewise.

The proper length of a side rod, between center and center of boxes, should be identical with the distance between center and center of the axles of these wheels and if a little adjustment is required for the pedestal boxes, the centers of both rod and axles should be *trammed* to see if they agree. But this is a job for the shop man.

Any other derangements noticed by the engineer are reported by him to the shop foreman for attention by his staff.

**End of Run.** At the termination of his run the engineer should come into his last station with a thin fire on his grates and just enough steam to make the roundhouse. Whether he leaves his engine at this point depends on the relative locations of the depot and roundhouse. In some localities the engineer must take his train into the yards and shunt it into a siding before he leaves it; in others his engine is taken charge of by a man from the roundhouse, called a *hostler*, who takes the engine direct to the roundhouse while a switching engine does the shunting of the train.

When, however, the engineer returns to take out his train again he carefully looks the engine over to see that everything is in adjustment—all oil cups filled and working, fire in good shape, steam and air pressures right, and the hose couplings properly connected. He should also look into his sand box (this should really be done in the roundhouse) to see that his supply of sand is sufficient and dry enough to run out if required. When he has tried his air to see if the brakes are working, he is ready for another start.